

# Excellence for industrial coating.

## Experience

### WAGNER

WAGNER is one of the market leading manufacturers of high tech systems and components for the application of liquid and powder lacquers and other paints to surfaces. WAGNER offers a complete product and technology range, starting with feeding the material to mixing, dosing, motion and control technology including material logistics; finishing with the application of various materials to the surfaces.

The WAGNER Group operates globally with approximately 1,450 employees, 19 operative companies and about 300 international WAGNER sales branches. We have seven technology centers for research and development worldwide: In workshops equipped with the latest technology customers may apply coating to their product under real-life production conditions and determine the most cost-effective system configuration.

We ensure the high quality of all WAGNER products with a quality assurance system covering all business processes: design and development, production, process technology, marketing, sales and service.

#### Consultation / contact person

We would be happy to advise you over the phone, alternatively please send an email to:

Customer Service Export:  
Tel.: +49 (0) 7544 - 505 1927  
E-Mail: [cs-international@wagner-group.com](mailto:cs-international@wagner-group.com)

Technical Support Powder:  
Tel.: +49 (0) 7544 - 505 1924  
[ts-powder@wagner-group.com](mailto:ts-powder@wagner-group.com)

The big WAGNER  
Powder application  
2014

Legend



Powder application

## Experience fascinating surfaces



Products from WAGNER Industrial Solutions stand for maximum reliability, quality for your specific requirements.

Furniture, walls, garden fences, construction machines, mobile phones, wheel rims, leather sofas, or perfume bottles - there is hardly any object that does not come with a coating. The reason is obvious: among others, the surface determines the function, durability and the attractiveness of an object.



Join us in the world of perfect surfaces. Our know-how makes WAGNER one of the world's leading manufacturers of devices and system for surface coating. Be inspired and rest assured that you will find the best solution for you here.

# Content



	Venturi feed	10	Feeding/preparation
	IP 5000	14	
	Peristaltic feed system	16	
	PrimaCenter	18	
	Comfort Powder Centers	22	
	SuperCenter	26	
	Basic powder center	30	
	Manual application systems	38	Applying
	Automatic application systems	48	
	Accessories	52	
	Manual booths	60	Booths
	Automatic booths	66	
	Accessories	75	
	Cyclones	80	Recovery
	Filter	82	
	Accessories	88	
	Linear units	92	Moving
	Accessories	102	
	PrimaTech controllers	106	Control
	ProfiTech M controllers	116	
	ProfiTech S controllers	122	
	Accessories	124	
	PrimaCube complete system	130	Complete system
	PrimaCube booth package	136	
	PrimaCube movement packages	138	
	Accessories	139	

## We accept challenges.

**WAGNER Industrial Solutions** offers devices, equipment, and systems for all industrial surface coating applications. Our innovative products and solutions stand out due to their quality, efficiency and productivity.

As a market leading manufacturer of high tech systems, we offer components for the application of liquid and powder lacquers and paints to surfaces. As one of the few providers in this market we offer a complete product and technology range for the complete process sequence, starting with feeding the product, followed by mixing, moving and controlling to finishing the optimal application to the surface. Efficient use of resources, maximum quality and cost-effectiveness is our maxim - in every case!



### **WAGNER Development center**

The modernly equipped WAGNER Development Center sets new standards for the development of products and solutions for the surface coating industry - be it for the first idea or the series production start. The WAGNER Development Center also ensures compliance with all national and international standards and regulation as part of the product development.

### **WAGNER Technology center**

At our Markdorf location, WAGNER has a unique technology center with a floor space of more than 1,400 m<sup>2</sup> for liquid and powder coating. Here products and systems can be coated with liquid and powder lacquers under real-life production conditions. On the basis of insights gained during these trials, efficient system concepts are developed and implemented in cooperation with our experts.

### **WAGNER Service**

Always near you - the WAGNER service network. WAGNER offers its customers global service. At our locations you will always find the right contact person with an answer to all technical questions. Regular maintenance of your system ensures high process safety and reliability. The latest developments and updates may be very useful for your processes. We gladly share this knowledge with you. Either during servicing - as we are already on site, or please take advantage of our training program!

### **WAGNER Distribution support**

Become a WAGNER distributor: We offer a comprehensive sales support and provide comprehensive documentation, tools, and further information, our highly qualified members of staff are here to assist you.

Here some examples:

- Product and accessories catalog
- price lists
- brochures, posters etc.
- operating manuals
- InfoNet - the WAGNER IS
- WAGNER dealer shop
- Information portal



# Discover what is **New at WAGNER.**

Discover the new products and innovations for 2014!



WAGNER

Manual powder gun

## PEM-X1 Corona manual gun

Perfect balance, maximum service life and optimum handling. Perfectly balanced ergonomics ensure flexible and fatigue-free operation. Everything necessary for a perfect surface.

See page 39



WAGNER linear units

## Movement system

The motion technology is flexibly applicable. Whether long or short strokes, with this technology any motion sequence may be executed with precision.

See page 92

Intelligent control systems

## ProfiTech M

This way you easily and safely achieve perfect results using the automated coating process. Intuitive and easily understandable, saving time and ensuring maximum efficiency.

See page 117



# Maximum flexibility for efficient supply.

A close-up photograph of industrial powder supply components. The image shows several brass-colored metal fittings and connectors arranged in a row, with grey hoses attached to them. The background is dark and out of focus, emphasizing the metallic parts in the foreground.

As the heart of the powder supply, the powder center ensures that the required quantity of powder is fed from the original container to each application area (e.g. guns). Regardless from which powder tank you feed the material, whether from the original container, drums, etc., our experts will assist you in selecting the right solution for your coating needs.



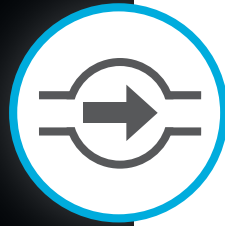

## Feeding/preparation

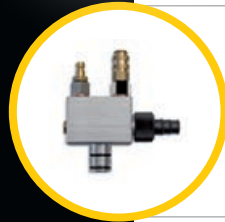

Venturi feed

10



IP 5000

14



Peristaltic feed system

16



PrimaCenter

18

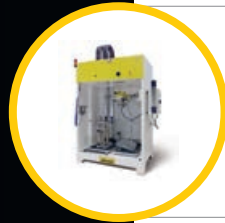

Comfort Powder Centers

22



SuperCenter

26



Basic powder center

30

## Venturi feed

WAGNER powder injectors are based on the Venturi principle for the transport of the coating powder from a container to the gun. Here WAGNER uses suspension feeding to ensure a constant powder output without spitter. Suspension feeding allows also a highly flexible volume adjustment, which is a basic requirement for some applications. The powder volume is set by changing the supply or dosing air. Here the relevant WAGNER control units automatically set the right ratio between supply and dosing air using the precision regulator. Thus the WAGNER injectors distinguish themselves by their easy operation and low maintenance. This ensures high process reliability for the user.

Feeding/preparation

Venturi feed

### 1. Easy operation and maintenance

The use of quick couplings and intuitive connecting elements ensures easy operation and maintenance.

### 2. High Surface quality

The use of conductive materials allows for the dissipation of interfering charges, which in turn ensures homogeneous surfaces.

### 3. Cost-effectiveness

The separately usable collector nozzle and its robust design ensure low wear part costs for the WAGNER Venturi feed.

### 4. Wide range of applications

A high output ranges allows for diverse applications and such ensures high degree of flexibility.

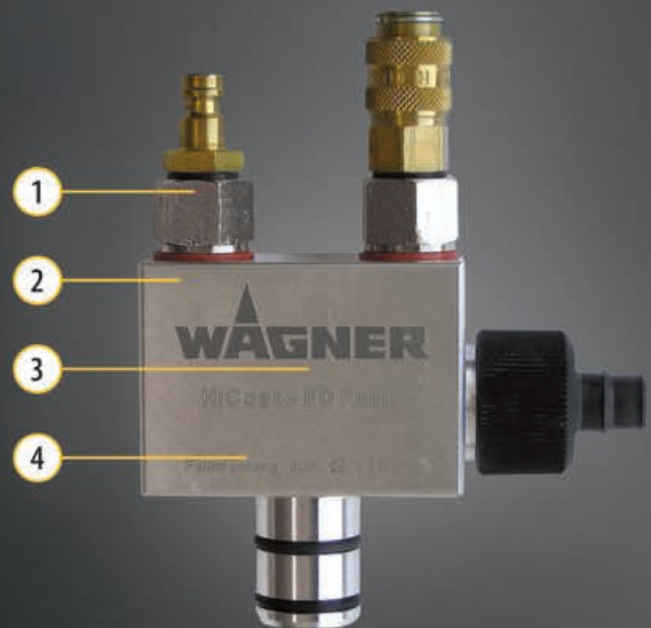

## Standard injectors

Feed system for supplying powder to powder guns according to/ following the Venturi principle.

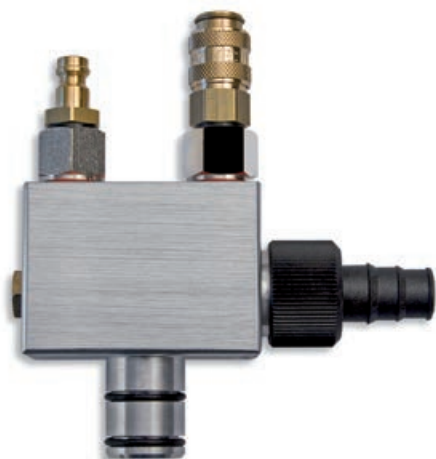

Technical data	
Max. delivery head	4,0 m, 13,1 ft
Max. feed line length	15 m, 49,2 ft
Depth	110 mm, 4.3 in
Feed line, inside Ø	10 – 12 mm, 0.4 – 0.5 in

### Special advantages

- High output range  
Wide range of applications
- Easy to operate and maintain  
No special training necessary
- Collector nozzle as a separate wear part  
Lower wear part costs
- Conductive hose sleeve  
Discharge of unwanted electric charge

### Processable materials

- Corona powder
- Tribo powder
- Commercially available metallic powders

### Included Items

- Powder injector

Product variants	Item no.	Price	PH 2
Powder injektor PI-P1	241621		- -
Powder injektor PI-P1	241622		- -

## HiCoat-ED feed system

Feed system for supplying powder to powder guns with little air according to the Venturi principle.



Technical data	
Max. delivery head	4,0 m, 13,1 ft
Max. feed line length	10 m, 32,8 ft
Width	28 mm, 1.1 in
Height	115 mm, 4.5 in
Depth	110 mm, 4.3 in
Feed line, inside Ø	8 – 10 mm, 0.3 – 0.4 in

Feeding/preparation

Venturi feed

### Special advantages

- Supplies powder using little air  
More even coating thickness
- Efficient material utilization  
Lower material consumption costs
- Better coating coverage in depressions  
Higher coating speed
- No pulsing of powder cloud  
Higher transfer efficiency

### Processable materials

- Corona powder
- Tribo powder
- Commercially available metallic powders

### Included Items

- HiCoat-ED feed system

Product variants	Item no.	Price	PH 2
HiCoat-ED Pump P	241623		-
HiCoat-ED Pump F	241624		-

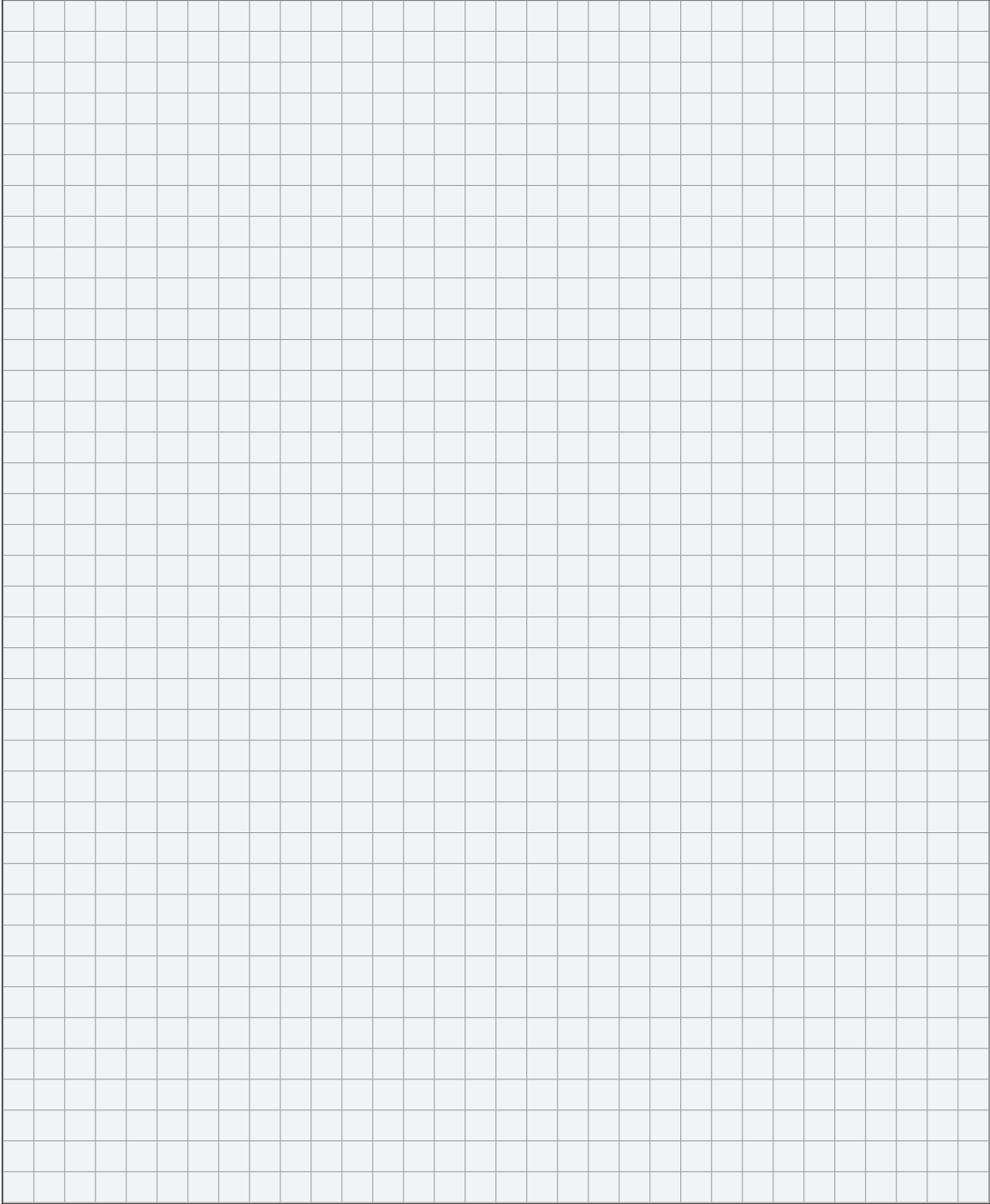

## IP 5000

The IP 5000 is a vacuum supported hose pump for intermediate dosing or feeding. It makes high feed rates with low air requirements and long feed distances of up to 50 meters easily possible. This new pump is suitable for all types of feeding options without restrictions for container sizes.

### 1. Rapid paint changes

Easy operation, all keys have a single function. The automatic cleaning program for suction and feed direction as well as the adjustable flushing function ensure a quick paint change.

### 2. Highest efficiency

Four preset and freely programmable recipes for flat and complex parts as well as for the post-coating avoid time-consuming manual adjustments of the electrostatics. The active service interval indicator displays the remaining running time and ensures optimum maintenance processes.

### 3. Reliability

The pump allows for high flow rates with low air requirements. Long feed distances of up to 50 meters are easily possible.

### 4. High performance

The basis for the constant and above all high feed performance is the combination of vacuum and dense stream feed.

### 5. Flexibility

Feeding can be directly from the carton, from 200 l drums or from the Big Bag. The IP 5000 is also suited for the emptying of final filter tank and allows for any feeding between the powder storage locations to be integrated perfectly into the production process.

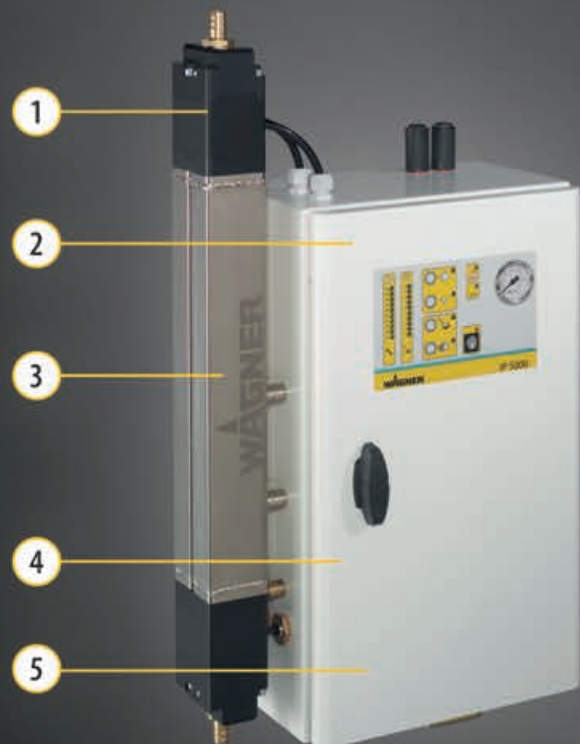

## IP 5000

Feed system for the low-air feed of large quantities.



Technical data	
Valve control voltage	24 V
Air inlet pressure	0,6 – 0,8 MPa, 6,0 – 8,0 bar, 87 – 116 PSI
Max. delivery head	5,0 m, 16,4 ft
Max. feed line length	50 m, 164,0 ft
Max. powder feed rate	5000g/min, 11.0 lb/min

### Special advantages

- High delivery rate of up to 5 kg/min
- Low-air feed system  
Minimal dust formation
- Service interval display  
No unscheduled interruptions in production
- Automatic flushing and cleaning programs  
Safe and rapid color change

### Processable materials

- Corona powder
- Tribo powder
- Commercially available metallic powders

Product variants	Item no.	Price	PH 2
Powder pump IP5000	241004		-

## Peristaltic feed system

The peristaltic feed pump (also peristaltic feeder) is used for the intermediate feeding of coating powders using little air by means of alternating pinch valves. This is a passive system that is filled from above. A typical application is feeding powder recovered from a cyclone. The peristaltic feed pump includes a control that coordinates the alternating operation of the valves and thus the blow-out cycles. This system offers robustness and paint change reliability.

Feeding/preparation

Peristaltic feed system

### 1. High Efficiency

The design of the feeder allows for large feed capacities with low investment costs.

### 2. Reliability

Robust technology ensures high availability and safety.

### 3. Optimal Maintenance

Low-wear feed technology ensures low maintenance.

### 4. Energy Efficiency

The low-air feeding with little formation of dust reduces energy costs.

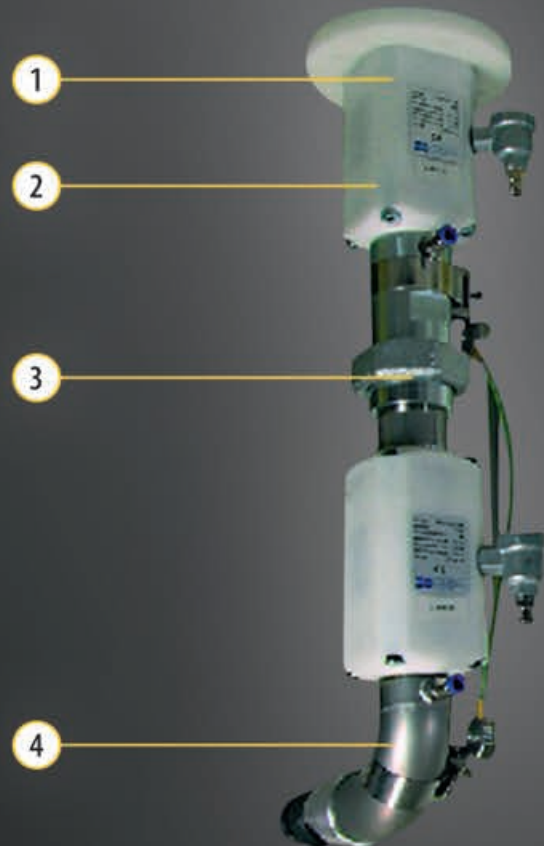



## Peristaltic conveyor system

The peristaltic conveyor system is used for the intermediate feeding of coating powders using little air by means of alternating pinch valves.



Technical data	
Input voltage	24 V
Input power	25 W
Protection class	IP 55
Air inlet pressure	0,6 MPa, 6,0 bar, 87 PSI
Max. delivery head	1,5 m, 4,9 ft
Max. feed line length	12 m, 39,4 ft
Max. powder feed rate	2000 g/min, 4.4 lb/min

### Special advantages

- Feed requires little air  
Minimal dust formation
- Large delivery capacity  
Low investment costs
- Low-wear feed technology  
Low maintenance
- Robust engineering  
High availability

### Included Items

- Peristaltic conveyor system with pinch valves
- Control cabinet with control unit

Product variants	Item no.	Price	PH 2
Stopper conveyor system 1-fold straight	3145309		- -
Stopper conveyor system 1-fold bent	3145301		- -
Double peristaltic pump system straight	3145534		- -
Double peristaltic pump system 90°	3158995		- -

## PrimaCenter

The WAGNER PrimaCenter fulfills all requirements for the powder supply of a simple paint change system. Quick paint changes thanks to automated subprocesses reduce the system downtime significantly. The PrimaCenter convinces with its robust technology and easy operation. All components are visible and the functions can easily be checked. The compact design allows for the installation of this powder center into systems with limited available space and ensures the introduction of quick paint changes.

Feeding/preparation

PrimaCenter

### 1. Compact design

Easy integration into new and existing systems.

### 2. Very easy operation

All processes are controlled using very few operating elements.

### 3. Pneumatic reciprocator

Easy and safe to operate. The automatic lifting and lowering of the powder injectors makes coating and paint changing processes easier.

### 4. Supply from fluid tanks.

The use of fluid tanks for powder preparation ensures an optimal flow rate and good atomization for the best coating results.

### 5. Integrated level sensor

Monitoring the filling level of the coating powder prevents faulty coating.

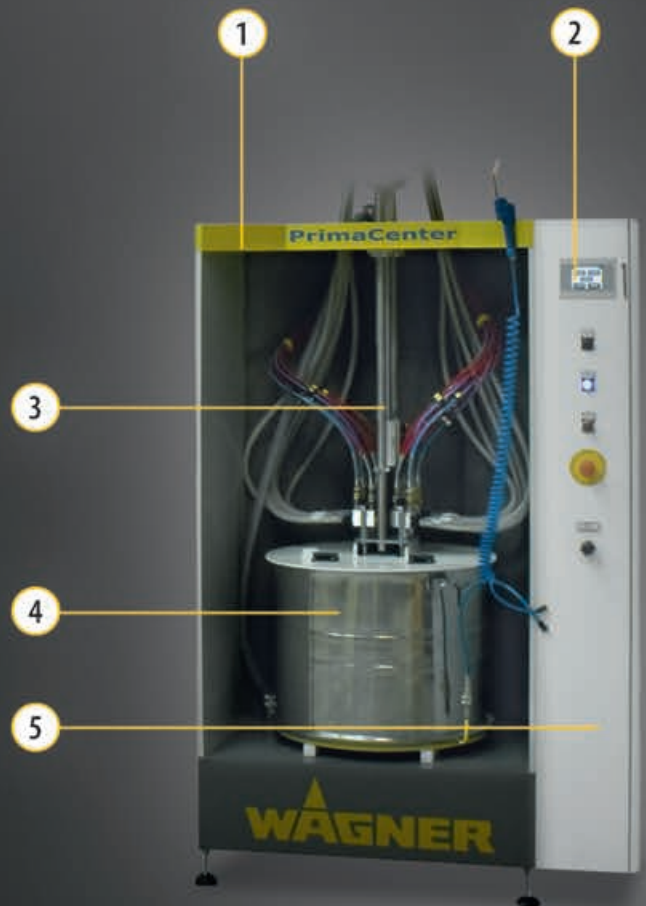

## PrimaCenter standalone

The PrimaCenter standalone can accommodate up to 12 powder injectors. It is designed for the powder feed into the paint change system and permits a simple paint change through partially automated cleaning procedures.



Technical data	
Min. compressed air hose cross section	25,40 mm, 1 in
Air inlet pressure	0,6 – 0,8 MPa, 6,0 – 8,0 bar, 87 – 116 PSI
Air consumption	25 Nm <sup>3</sup> /h
Width	800 mm, 31.5 in
Height	2216 mm, 87.2 in
Depth	800 mm, 31.5 in

### Special advantages

- Robust, compact design  
Space-saving construction
- Delivery from the fluid container  
High-quality coating results
- No power connection required
- Few control elements  
Easy to operate

### Included items

- PrimaCenter case with attached controller.
- Pneumatic reciprocator with injector socket
- 12 suction systems; suction systems that are not required can be removed and used as spare parts.
- Spring-loaded weighing system for use as level sensor.
- Pneumatic slide for opening/closing the exhaust air connection.
- Without powder tank (3918797)

### Ordering information

- Art.no. PrimaCenter Standalone 2311500
- Order powder container separately (3918797).
- Use for connection to a secondary filter spiral hose (2312336).

Product variants	Item no.	Price	PH 2
PrimaCenter standalone	2311500		-

## PrimaCenter Integral

The PrimaCenter Integral can accommodate up to 12 powder injectors. It is designed for the powder supply in the paint change systems and ensures a simple paint change through partially automated cleaning procedures.



Technical data	
Min. compressed air hose cross section	25,40 mm, 1 in
Air inlet pressure	0,6 – 0,8 MPa, 6,0 – 8,0 bar, 87 – 116 PSI
Air consumption	25 Nm <sup>3</sup> /h
Width	800 mm, 31.5 in
Height	2216 mm, 87.2 in
Depth	800 mm, 31.5 in

Feeding/preparation

PrimaCenter

### Special advantages

- Robust, compact design  
Space-saving construction
- Delivery from the fluid container  
High-quality coating results
- Electronic controller with 4" paint touch-screen  
Integratet application control in combination with EPG Sprint and moving devices VU, HU
- Icons and text  
Easy to operate

### Included items

- PrimaCenter case with attached controller.
- Pneumatic reciprocator with injector socket
- 12 suction systems; suction systems that are not required can be removed and used as spare parts.
- Spring-loaded weighing system for use as level sensor.
- Pneumatic slide for opening/closing the exhaust air connection.
- Without powder tank (3918797)
- Peristaltic feed pump controller

### Ordering information

- Art.No. PrimaCenter Integral 2330014
- Order powder container separately (3918797).
- Use for connection to a secondary filter spiral hose (2312336).

Product variants	Item no.	Price	PH 2
PrimaCenter integral	2330014		- -

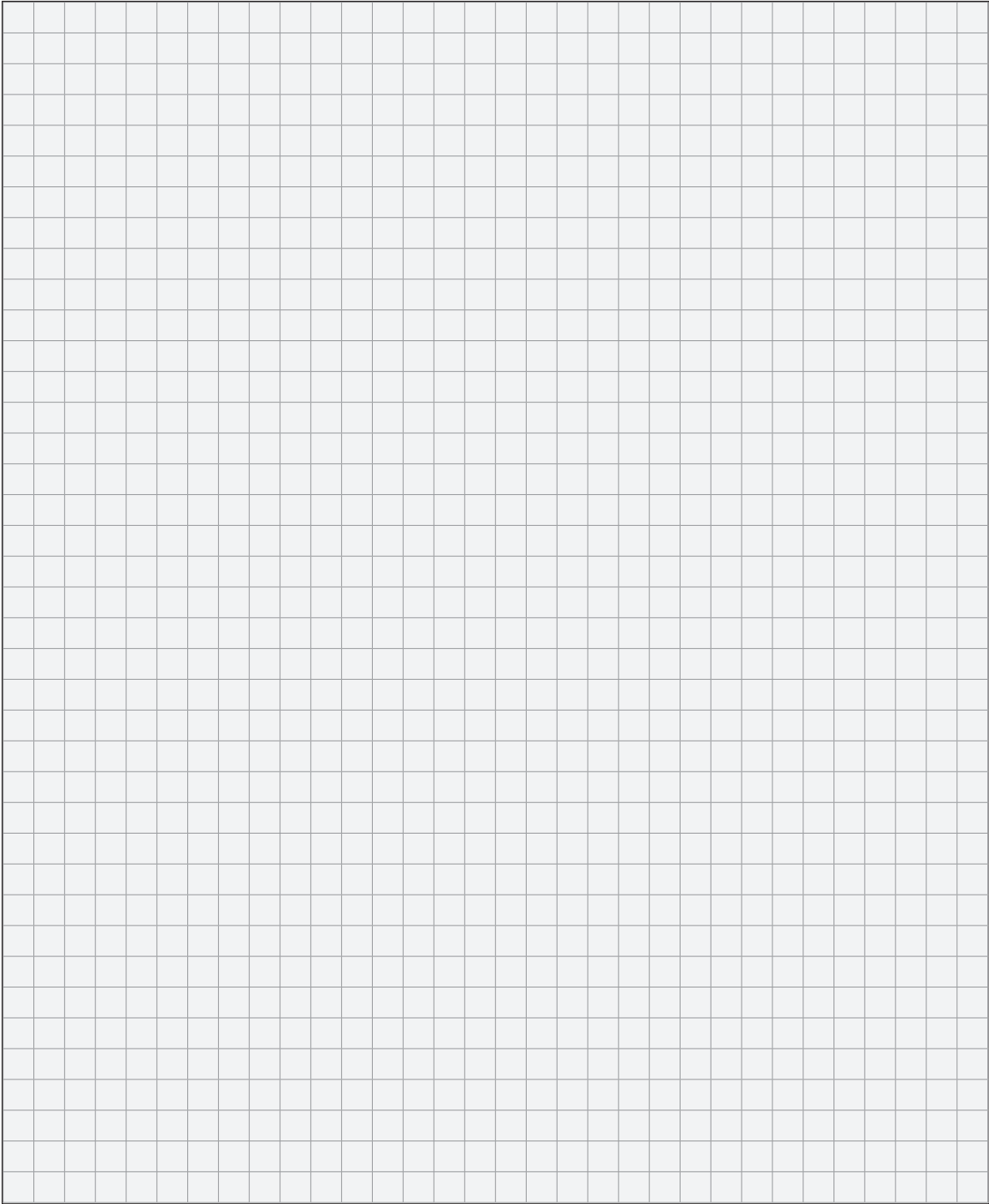

## Comfort Powder Centers

The Comfort Powder Feed Center is at the heart of the powder supply for any paint change system. It is designed for the supply of up to 27 spray guns. One option is to feed directly from the powder carton, or for very high coating surface quality requirements feeding from a fluid tank is possible. Various variants and accessories provide options to fulfill individual customer requirements. The basis system may for example be upgraded with a fresh powder supply unit IP 5000. For the highest quality requirements an ultrasound sieve may be integrated. Various blow-out devices are installed for a rapid paint change.

Feeding/preparation

Comfort Powder Centers

### 1. High Overall Feed Performance

The Comfort Powder Center ensures the supply of up to 27 powder injectors from the carton.

### 2. User-friendliness

Touch-screen user interface for an easy and self-explanatory operation of all functions.

### 3. Rapid Paint Change

Integrated automatic impulse flushing modules ensure a quick paint change and thus low downtimes.

### 4. High Performance

A constant infeed depth of the suction pipes allows for a constant powder output.

### 5. Flexibility

Separate vibration tables for circulation and fresh powder supply.

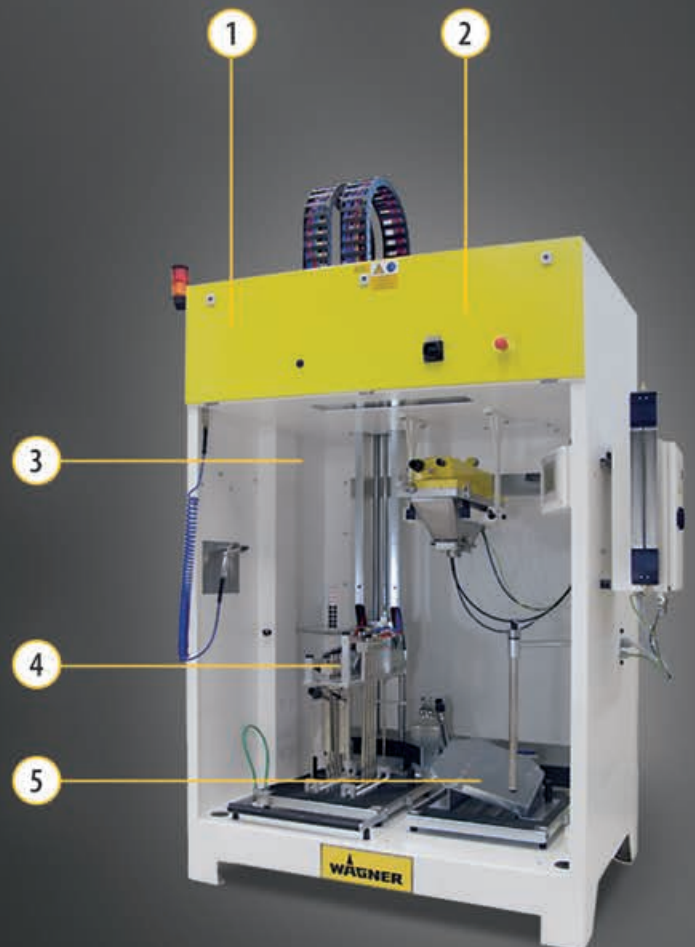

## Convenience powder feed center 18/27 with fresh powder delivery

The convenience powder feed center can supply powder to up to 27 spray guns. A fresh powder supply unit ensures that operation is not interrupted. Various blow-out devices facilitate a rapid color change.



Technical data	
Vibration motor power	190 W
Min. compressed air hose cross section	25,40 mm, 1 in
Air inlet pressure	0,6 – 0,8 MPa, 6,0 – 8,0 bar, 87 – 116 PSI
Three-phase current connection	220–240 / 380–420 V at 50 Hz
Air consumption	25 Nm <sup>3</sup> /h
Width	1500 mm, 59.1 in
Height	3000 mm, 118.1 in
Depth	1650 mm, 65.0 in

### Special advantages

- Supplies up to 27 powder injectors from the box  
High overall delivery rate, even in large systems
- Integrated automatic pulse flush modules for suction pipes, injectors, powder hoses and peristaltic conveyor unit  
Rapid color change
- Touchscreen control panel for all functions  
Simple, self-explanatory operation

### Processable materials

- Corona powder
- Tribo powder
- Commercially available metallic powders

### Ordering information

- Order suction systems and powder injectors separately.
- If more than 18 injectors are used, the fluidization add-on kit no. 3306758 is required.

Product variants	Item no.	Price	PH 2
Deluxe PZ 2008-FP with norm. container	3313141		- -

## Convenience powder feed center 18/27 without fresh powder delivery

The convenience powder feed center can supply powder to up to 27 spray guns. Fresh powder is supplied manually. Various blow-out devices facilitate a rapid color change.



Technical data	
Vibration motor power	95 W
Min. compressed air hose cross section	25,40 mm, 1 in
Air inlet pressure	0,6 – 0,8 MPa, 6,0 – 8,0 bar, 87 – 116 PSI
Three-phase current connection	220–240 / 380–420 V at 50 Hz
Air consumption	25 Nm <sup>3</sup> /h
Width	1500 mm, 59.1 in
Height	3000 mm, 118.1 in
Depth	1650 mm, 65.0 in

Feeding/preparation

Comfort Powder Centers

### Special advantages

- Supplies up to 27 powder injectors from the box  
High overall delivery rate, suitable for large systems
- Integrated automatic pulse flush modules for suction pipes, injectors, powder hoses and peristaltic conveyor unit  
Rapid color change
- Touchscreen control panel for all functions  
Simple, self-explanatory operation

### Processable materials

- Corona powder
- Tribo powder
- Commercially available metallic powders

### Ordering information

- Order suction systems and powder injectors separately.
- If more than 18 injectors are used, the fluidization add-on kit no. 3306758 is required.

Product variants	Item no.	Price	PH 2
Deluxe PZ 2008 with norm. container	3313143		- -



## Suction systems

Suction system assy. for Wagner comfort Powder Center



### Technical data

Inside Ø	10 mm, 0.4 in
----------	---------------

### Included Items

- Suction tubes, 10 mm inside diameter short or long version
- Fixture for powder pumps, short or long version
- Cleaning air nozzles
- Air hoses
- Quick couplings and plug-in nipples for injectors
- Flat sealrings and reduction sleeves for injectors
- without powder injectors

Product variants	Item no.	Price	PH 2
Suction system 1x short	3310411		--
Suction system 2x short	3310412		--
Suction system 3x short	3310413		--
Suction system 4x short	3310414		--
Suction system 5x short	3310415		--
Suction system 6x short	3310416		--
Suction system 7x short	3310417		--
Suction system 8x short	3310418		--
Suction system 9x short	3310419		--
Suction system 1x long	3310420		--
Suction system 2x long	3310421		--
Suction system 3x long	3310422		--
Suction system 4x long	3310423		--
Suction system 5x long	3310424		--
Suction system 6x long	3310425		--
Suction system 7x long	3310426		--
Suction system 8x long	3310427		--
Suction system 9x long	3310428		--

## SuperCenter

The SuperCenter is at the heart of the powder supply for any paint change system. It is designed for the supply of up to 22 spray guns. Feeding from a small fluid tank ensures an efficient powder usage at the highest quality requirements. Thanks to the integrated fresh powder supply an uninterrupted coating operation is ensured. The SuperCenter offers smart user guidance for coating and paint changes as well as the unique powder consumption recording feature. Various variants and accessories provide options to fulfill individual customer requirements. For the highest quality requirements an ultrasound sieve may be integrated. Thanks to the intelligent user guidance, quick paint change is reliable and reproducible.

Feeding/preparation

SuperCenter

### 1. 8" Color Touchscreen

USB interface for downloading consumption data.

### 2. Fresh Powder Feed

with automatic cleaning station, pump positioned laterally.

### 3. Semi-automated

tank blow-out unit

### 4. Powder Injectors

with upward hose guide.

### 5. Automatic Carton Change System

Left: Empty carton, center: working position, right: new carton prepared.

### 6. Fluid Tank

with weighing device.

### 7. Suction Pipes

with cleaning system.



# SuperCenter

The SuperCenter is a truly high tech powder supply unit for up to 22 guns. The integrated weighing technology not only keeps the powder level constant, but measures the powder consumption at every paint change.



## Special advantages

- Connection to the secondary filter  
No additional energy consumption
- Automated processes  
Operating safety and repeatability
- Detailed operator guidance when performing color changes  
Safe and reproducible paint change
- Powder consumption measurement and documentation  
Calculation basis and monitoring options

## Included Items

- The housing opens to the front and comes with a roof luminaire, the supply area has transparent doors.
- Suction opening with pneumatic throttle valve for connection to a final filter.
- Mounting console for up to 22 powder injectors.
- Pneumatically powered reciprocator for the fluid tank.
- Various blow-out units for automated paint change.
- Scraper system for the suction pipes
- Integrated fresh powder supply unit IP 5000
- Powder level sensors for reclaimed powder and fresh powder
- Touch operating panel for coating, paint change and setup mode.
- Special operating mode for small batches

## Ordering information

- SuperCenters are planned individually in the Wagner engineering departments.

Product variants	Item no.	Price	PH 2
SuperCenter 6-fold, cpl. w/o Injector	2329419		- -
SuperCenter 8-fold, cpl. w/o Injector	2329421		- -
SuperCenter 9-fold, cpl. w/o Injector	2329422		- -
SuperCenter 10-fold, cpl. w/o Injector	2329423		- -
SuperCenter 11-fold, cpl. w/o Injector	2329424		- -
SuperCenter 12-fold, cpl. w/o Injector	2329430		- -
SuperCenter 13-fold, cpl. w/o Injector	2329432		- -
SuperCenter 14-fold, cpl. w/o Injector	2329434		- -
SuperCenter 15-fold, cpl. w/o Injector	2329435		- -
SuperCenter 16-fold, cpl. w/o Injector	2329436		- -
SuperCenter 17-fold, cpl. w/o Injector	2329437		- -
SuperCenter 18-fold, cpl. w/o Injector	2329438		- -
SuperCenter 19-fold, cpl. w/o Injector	2329439		- -
SuperCenter 20-fold, cpl. w/o Injector	2325521		- -
SuperCenter 21-fold, cpl. w/o Injector	2329440		- -
SuperCenter 22-fold, cpl. w/o Injector	2328097		- -

## Ultrasound sieve unit SuperCenter

The ultrasound sieve unit was especially developed for use with the SuperCenter and ensures a high sieve performance. It is integrated in the cleaning process. The cool sieve technology provides process safety thanks to the reduction of the sieve heating risk.



Technical data	
Input voltage	100 – 240 V
Input frequency	50 – 60 Hz

Feeding/preparation

SuperCenter

### Special advantages

- Compact integration in the SuperCenter  
No additional space requirements
- High sieve performance  
No restrictions to the surface coverage of the system
- Integrated debris removal  
Achieve the highest coating quality

### Processable materials

- Corona color powder
- Tribo color powder
- Common commercial metallic color powder

### Ordering information

- For installation in SuperCenter starting in 2013
- Including sieve frame with sieve
- The sieve performance depends on the mesh size and powder in general. All mentioned powder flow information can only be seen as approximate values and can not be guaranteed.

Product variants	Item no.	Price	PH 2
US-Sieving machine 350/200	2335024		- -
US-Sieving machine 350/160	2335025		- -
US-Sieving machine 350/400	2335026		- -

## Ultrasound sieve unit for the Comfort Powder Center

The ultrasound sieve unit was especially developed for use with the Comfort Center and ensures a high sieve performance. The open design ensures easy operation and paint change safety. The cool sieve technology provides process safety.



### Special advantages

- Compact integration into the Comfort Center  
No additional space requirements
- High sieve performance  
No restrictions to the surface coverage of the system
- Integrated debris removal  
Achieve the highest coating quality

### Processable materials

- Corona color powder
- Tribo color powder
- Common commercial metallic color powder

### Technical data

Input voltage	100 – 240 V
Input frequency	50 – 60 Hz

### Ordering information

- For installation in Comfort Center 2008
- Including sieve frame with sieve
- The sieve performance depends on the mesh size and powder in general. All mentioned powder flow information can only be seen as approximate values and can not be guaranteed.

Product variants	Item no.	Price	PH 2
US-Sieving machine 350/160 add-on set	2337790		- -
US-Sieving machine 350/200 add-on-set	2335786		- -

## Basic powder center

The basis powder center is primarily designed for the powder feeding in single-paint systems. It is available as a modular system with various stages of expansion. The basic configuration consists of a fluid tank with suction pipes as required for the number of guns to be supplied. Depending on the particular task, the system can be extended by adding the level sensor, vibration table and sieve equipment modules.

Feeding/preparation

Basic powder center

### 1. Excellent surface quality

The optional use of ultrasound or rotary sieves allows for an improved powder quality.

### 2. High feed capacity

The basis powder center ensure optimum supply of up to 12 powder injectors.

### 3. High performance

The fluidization of the complete tank content ensures an even powder feed.

### 4. Optimum coating quality

Optimal powder preparation using an optional vibration table ensures premium coating quality

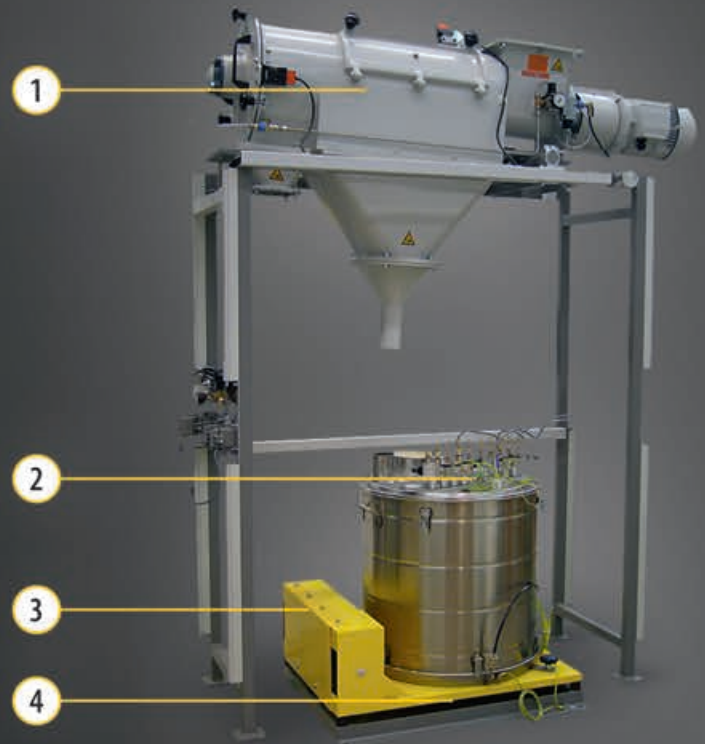

## Basic powder center

The powder center is available as a modular system with various stages of expansion. The basic configuration consists of a fluid tank with corresponding suction pipes. It can be individually expanded with other components.



### Special advantages

- Powder container with up to 12 powder injectors  
Large delivery capacity
- Fluidized container  
Even powder delivery
- Optional vibration table  
Optimal powder preparation for premium coating quality
- Optional sieving equipment (ultrasonic or rotary sieve)  
Maximization of surface quality

### Processable materials

- Corona powder
- Tribo powder
- Commercially available metallic powders

### Included Items

- Depending on the required functions:
- Fluidized container
- Pick-up tubes
- Level sensors min. and max.
- Vibration table
- Rotary sieve unit or ultrasonic sieve unit
- Fresh powder supply unit

### Ordering information

- Basic powder centers will be individually designed to fulfil specific customer demands.
- The WAGNER engineering department will make an offer on request within a very short period of time.

## Feeding/preparing accessories

Wagner offers a comprehensive accessories range for feeding and preparing powder lacquers. Please select the components you require from this table.

● Are compatible to each other

Feeding/preparation

PI-F1	HiCoat-ED F	IP 5000	Single peristaltic conveyor	Double peristaltic conveyor	PrimaCenter Integral	Convenience powder feed center 18/27 with fresh powder delivery	Convenience powder feed center 18/27 without fresh powder delivery	SuperCenter	Basic powder center	Ultrasound sieve unit SuperCenter	Ultrasound sieve unit for the Comfort Powder Center
-------	-------------	---------	-----------------------------	-----------------------------	----------------------	---	--	-------------	---------------------	-----------------------------------	---

Container													
Powder Container PrimaCenter						●						3918797	-
Powder Container ITEP cpl.							●	●				3304505	-
Fluid container with US-Sieve									●			3944635	-
Powder hopper SuperCentre w/o US-sieve									●			3941206	-
Powder hopper 120L for 12 pick-up tube										●		263097	-
Powder hopper 120L w. cover										●		263098	-

Connector, coupling													
Union with push in nipple	●	●										9992200	-
Coupling union	●	●										9992711	-
Hose adapter D8/10 ET	●	●										390936	-
Coupling part G1"				●	●							3133830	-
Adapter for hose d20				●	●							3146950	-

Air hose													
Hose PU 8/5,5 rot	●	●										9982063	-
Hose blue D 8x1.25	●	●										9982062	-
spiralhose PVC grey d150						●						2312326	-

Powder hose													
Powder hose D10	●	●										2310699	-
Powder hose D11	●											2307502	-
Powder hose D12	●		●									2310700	-
Powder hose D9		●										351794	-
Powder hose D8		●										351798	-
Powder hose D14 (sieving machine)			●									2312126	-
hose PVC transp. Spirale NW20 7bar				●	●							3147211	-

Measurement tools													
Check bolt collector nozzle	●	●										241929	-

Fixture													
Mountingset ip5000			●									241550	-
Park station			●									241565	-
Pump frame IP5000			●									3313075	-
Schlauchklemme SKIFFY 18-20			●									3304988	-
Hose-holder 18-20			●									9987135	-
Hose clip 25-44				●	●							9990410	-
tubeclamp						●						2312576	-
Flange for Levelcontrol complete									●			3131985	-



## Feeding/preparing accessories

Wagner offers a comprehensive accessories range for feeding and preparing powder lacquers. Please select the components you require from this table.

● Are compatible to each other

PL-F1	HiCoat-ED F	IP 5000	Single peristaltic conveyor	Double peristaltic conveyor	PrimaCenter Integral	Convenience powder feed center 18/27 with fresh powder delivery	Convenience powder feed center 18/27 without fresh powder delivery	SuperCenter	Basic powder center	Ultrasound sieve unit SuperCenter	Ultrasound sieve unit for the Comfort Powder Center
-------	-------------	---------	-----------------------------	-----------------------------	----------------------	---	--	-------------	---------------------	-----------------------------------	---

Seperator													
Splash Damper PZ compl.			●									241555	-
Suction system													
SUCTION UNIT IP 5000 ASSY.			●									265110	-
SUCTION LANCE SN600/14			●									2301550	-
Suction unit sn1500/14			●									2301548	-
Injector socket set 4x									●			263630	-
Injector socket set-4x 80mm									●			2315713	-
Injector socket set-1									●			263629	-
Suction tube 120									●			263631	-
Blow-out system													
Cleaningbox			●									241570	-
Blind injector									●			701452	-
Assembly													
Thread adapter			●									2301253	-
Power cable													
Cable 12 polig			●									9956263	-
Parking													
Changeable hose guide assy.						●	●					3313481	-
Sonsor													
Level probe assy. 330 mm									●			3149089	-
Level probe assy. 665mm									●			3151891	-

## Feeding/preparing accessories

Wagner offers a comprehensive accessories range for feeding and preparing powder lacquers. Please select the components you require from this table.

● Are compatible to each other

Feeding/preparation

PI-F1	HICOAT-ED F	IP 5000	Single peristaltic conveyor	Double peristaltic conveyor	PrimaCenter Integral	Convenience powder feed center 18/27 with fresh powder delivery	Convenience powder feed center 18/27 without fresh powder delivery	SuperCenter	Basic powder center	Ultrasound sieve unit SuperCenter	Ultrasound sieve unit for the Comfort Powder Center
-------	-------------	---------	-----------------------------	-----------------------------	----------------------	---	--	-------------	---------------------	-----------------------------------	---

Accessories												
Reduction sleeve	●	●			●	●	●	●			241580	-
Flat seal	●	●			●	●	●	●			241581	-
Venturi nozzle	●										241225	-
Injektor nozzle sd	●										241923	-
Venturi nozzle HICOAT-ED		●									241229	-
Nozzle HICOAT-ED		●									241930	-
Service kit IP5000 Pump hose			●								2312057	-
Service kit IP5000 Valve hose			●								2312058	-
Pump hose			●								2301442	-
Hose flange outlet valve			●								241486	-
Hose sleeve				●	●						3144058	-
Quick-release valve FESTO SEU 1/4"				●	●						3102576	-
Check valve				●	●						3136837	-

Accessories												
Powder center add-on kit 27x Inject						●	●				3306758	-
control peristaltic valve integr.						●	●				3312611	-
Sieveframe 350/200 premounted						●	●	●		●	2326857	-
Holder for feed hopper						●	●	●		●	2332165	-
Sieveframe 350/160 premounted						●	●			●	2334066	-
Generator DGS35-50-S-A						●	●	●		●	2334267	-
Converter C35-S						●					2334269	-
HF cable for DGS35-50-S-A						●					2334271	-
Titanium bolt M10/M8x25mm						●	●	●		●	2335520	-
Sieveframe 350/400 premounted						●	●	●		●	2339366	-
Trolley for container 120l									●		263638	-

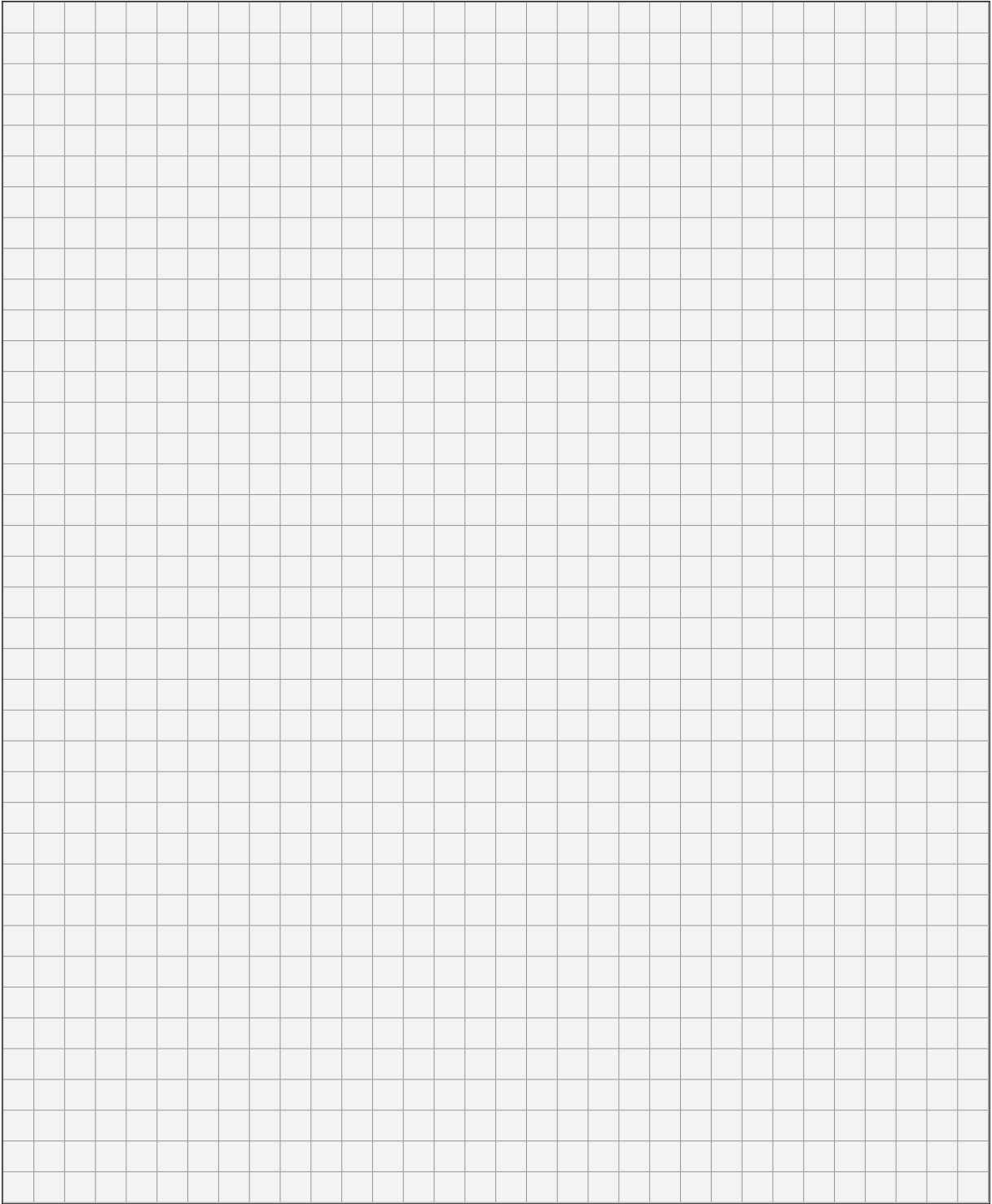

## Perfect Handling for optimal surfaces.



WAGNER application units are in use around the world and enable optimal coating results for all surface types. The new gun generation achieves greater efficiency and perfection, both in manual and in automatic coating applications. The WAGNER manual units are the result of continuous development efforts for greater performance. Thanks to their user-friendly design, the devices are easy and faster to work with.



## Applying

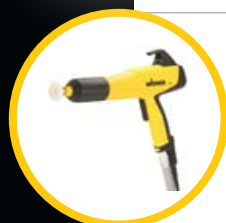

Manual application systems 38



Automatic application systems 48

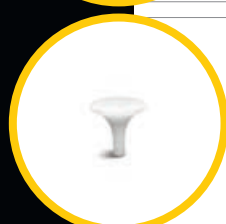

Accessories 52

## Manual application systems

Manual guns set new standards and trends for all kind of surfaces in modern powder coating. With the new gun generation maximum efficiency and perfection may be achieved - the product philosophy creates a completely balanced refinement and offers the longest service life plus optimum handling.

Applying

Manual application systems

### 1. Highest Flexibility

The great accessories selection (nozzles, extensions, hoses, etc.) allows for a diverse range of applications.

### 2. Highest Efficiency

WAGNER Air Flow Control (AFC) ensures optimum powder control and efficient coating processes.

### 3. Design and User Friendliness

The optimal arrangement of the user elements as well as the functional and elegant design allow for intuitive gun handling.

### 4. Perfect Handling

WAGNER manual guns are balanced to the final gram and ensure flexible and fatigue-free operation.



## PEM-X1 Corona manual gun

The PEM-X 1 combines balance, maximum service life and optimum handling perfectly. Perfectly balanced ergonomics ensure flexible and fatigue-free operation. WAGNER combines first-class design and functionality to achieve a perfect surface.



Technical data	
Max. input voltage	22 Vpp
Output voltage	100,0 kV
Polarity	Negative
Protection class	IP 64
Air inlet pressure	0,3 MPa, 3,0 bar, 44 PSI
Max. powder output	450 g/min
Operating temperature	5 – 45 °C, 41.0 – 113.0 °F
Weight	0,5 kg, 1.1 lb

### Special advantages

- Very light gun (490g)  
Despite its light weight, the gun is impressive due to its robust design and ergonomic working without tiring
- Homogeneous and stable powder cloud  
Even layer thickness distribution
- Optimally balanced  
Perfect grip in every situation due to a gun that is balanced down to the last gram
- Quick-release coupling for the powder hose  
makes the paint change easier und quicker

### Processable materials

- Polyester powder coatings
- Hybrid powder coatings
- Metallic powder coatings
- Acrylic powder coatings
- UDS powder coatings
- Effect powder coatings

### Included items

- Circular sprayer or flat sprayer nozzle system
- Connection cable 6m
- Sprayer air hose
- Wedge changing tool
- Printed BAL

Product variants	Item no.	Price	PH 2
Manual Spray Gun PEM-X1	2322587		- -
Manual Spray Gun PEM-X1 R	2335844		- -

## Cup-gun PEM-X1 CG

The simple handling and perfect ergonomics of WAGNER cup guns make them ideal for lab and development purposes and for powder coating individual items and very small quantities.



Technical data	
Max. input voltage	22 Vpp
Output voltage	100,0 kV
Polarity	Negative
Protection class	IP 64
Air inlet pressure	0,3 MPa, 3,0 bar, 44 PSI
Max. powder output	200 g/min
Operating temperature	5 – 45 °C, 41.0 – 113.0 °F
Weight	0,6 kg, 1.2 lb

Applying

Manual application systems

### Special advantages

- Simple plug-in principle for the cup  
Short and safe paint change times of approximately 15 seconds.
- Funnel beaker with special geometry  
The different slope angles ensure constant flow even with difficult powder types
- Integrated Venturi feeding principle  
Very fine and constantly homogeneous dosage dispensing of the powder quantity
- The coating parameters are set via the control module  
All coating-relevant parameters are saved and accessed via the fully electronic control module

### Processable materials

- Polyester powder coatings
- Hybrid powder coatings
- Metallic powder coatings
- Acrylic powder coatings
- UDS powder coatings
- Effect powder coatings

### Included items

- Gun cable 4m
- Wedge tool
- Funnel beaker with cover

Product variants	Item no.	Price	PH 2
Cup Gun PEM-X1 CG	2322588		- -



## Tribo hand guns

Tribo manual guns are designed for processing Tribo powders. They offer an excellent loading system, great ergonomics and are very light.



Technical data	
Polarity	Positive
Protection class	IP 54

### Special advantages

- Very lightweight gun  
Fatigue-free working over long periods
- Charging body can be dismantled  
Low wear part costs because high wear zones can be replaced separately
- Round spray nozzle and fan spray nozzle included  
Greater flexibility to master any coating task
- Easy-to-replace wear parts  
Low maintenance

### Processable materials

- Tribo powder

### Controller

- Individual control unit

Product variants	Item no.	Price	PH 2
Manual gun PEM-T3	351019		- -
Tribo cup-gun PEM-CG3	351036		- -

## Manual application systems

The new SPRINT manual system combines a functional and elegant design with comprehensive functionality. All parameters are divided into four functional sections and are entered at the EPG-Sprint X control unit using a central dynamic control dial. Its unique cascade characteristic curve settings together with its Tribo compatibility offer maximum flexibility for each and every powder. In combination with the new manual gun PEM-X1 this manual system delivers excellent coating results.

Applying

Manual application systems

### 1. Intuitive User Guidance

The optimal arrangement of the operating elements and functions as well as the unique adjustment of recipes allow for intuitive device handling. Advanced user functions allow you to store up to 50 coating recipes and to adjust many other parameters individually.

### 2. Rapid Paint Changes

A pre-programmed key, the suction lance positioning as well and the quick connector for the powder hose ensure a quick and safe paint change.

### 3. Modern Design

The new SPRINT manual system convinces with its easy and modern design. It provides the perfect solution for optimum manual coating, thanks to its robust and reliable quality.

### 4. Highest Flexibility

The carton device can be transformed into a tank version in a few simple steps. With various powder hoses and different injectors the SPRINT manual system can easily be adapted to your requirements.



## Manual system Sprint Airfluid

Using the Sprint AirFluid allows you to work directly out of the carton. Ideal for small batches and frequent paint changes. All parameters are set and saved via the EPG-Sprint X. In combination with the PEM-X 1, perfect surfaces are achieved.



### Special advantages

- Corona manual gun with an air-flushed high-performance cascade  
Constant and reliable coating performance
- Control unit with a regulated air volume cycle.  
A constant compressed air quantity despite fluctuations in the mains
- Fully electronic control unit for reproducible results  
Saving and accessing up to 50 coating programs
- Diagonal position of the powder container  
Powder carton is almost completely emptied

### Processable materials

- Polyester powder coatings
- Epoxy powder coatings
- Metallic powder coatings
- Acrylic powder coatings
- UDS powder coatings
- Effect powder coatings

### Technical data

Input voltage	85 – 250 V
Input power	40 W
Input frequency	50 – 60 Hz
Protection class	IP 64
Air inlet pressure	0,6 – 0,8 MPa, 6,0 – 8,0 bar, 87 – 116 PSI
Air inlet connection	G 1/4" i
Exhaust air flow	0,05 – 20,0 Nm <sup>3</sup> /h
Operating temperature	5 – 45 °C, 41.0 – 113.0 °F
Weight	38,0 kg, 83.8 lb

### Included items

- Corona manual gun PEM-X1
- Control device EPG-Sprint X
- Injector PI-F1
- Suction lance with fluid cap
- Device cart with vibrating table
- Powder hose 5m (Ø 11mm)
- Mains cable 3m
- Grounding cable 10m
- Connection hose

Product variants	Item no.	Price	PH 2
Manual Unit Sprint Airfluid	2329483		-

## Manual system Sprint 60 I

The Sprint 60L is used to fluidize the powder in a 60 liter stainless steel tank. All coating parameters are set and saved using the control unit EPG-Sprint X. In combination with the PEM-X 1, perfect surfaces are achieved.



Technical data	
Input voltage	85 – 250 V
Input power	40 W
Input frequency	50 – 60 Hz
Protection class	IP 64
Air inlet pressure	0,6 – 0,8 MPa, 6,0 – 8,0 bar, 87 – 116 PSI
Air inlet connection	G 1/4" i
Exhaust air flow	0,05 – 20,0 Nm <sup>3</sup> /h
Operating temperature	5 – 45 °C, 41.0 – 113.0 °F
Weight	38,0 kg, 83.8 lb

Applying

Manual application systems

### Special advantages

- Corona manual gun with an air-flushed high-performance cascade  
Constant and reliable coating performance
- Fully fluidized stainless steel container  
Optimal powder preparation for high quality requirements
- Clear and user-friendly operating interface  
For quickly and easily adjusting the coating parameters
- Up to 50 coating recipes can be saved  
Ideal for many color and object changes

### Processable materials

- Polyester powder coatings
- Epoxy powder coatings
- Metallic powder coatings
- Acrylic powder coatings
- UDS powder coatings
- Effect powder coatings

### Included items

- Corona manual gun PEM-X1
- Control device EPG-Sprint X
- Injector PI-F1
- Device cart (optional with a vibrating table)
- Powder hose 5m (Ø 11mm)
- Mains cable 3m
- Grounding cable 10m
- Connection hose
- Different stainless steel containers (sold separately)

Product variants	Item no.	Price	PH 2
Manual Unit Sprint 60L	2329489		-

## Cup gun case set

This set is a ready to use coating device. With air pressure and power supply the device is ready to start powder coating. An ideal solution for small parts and mobile use with excellent coating results.



### Special advantages

- Compact, mobile, and always ready to use  
A compact and very organized case set for mobile use.
- Perfectly balanced gun  
A secure grip on the gun that is easy on the joints in every situation
- Fully electronic control module  
Store and query complete coating recipes
- Special funnel beaker  
Thanks to various inclination angles virtually any powder type flows out until completely used up.

### Processable materials

- Polyester powder coatings
- Hybrid powder coatings
- Metallic powder coatings
- Acrylic powder coatings
- UDS powder coatings
- Effect powder coatings

### Technical data

Input voltage	85 – 250 V
Valve control voltage	24 V
Input power	25 W
Input frequency	47 – 440 Hz
Polarity	negative
Protection class	IP 64
Air inlet pressure	0,6 – 0,8 MPa, 6,0 – 8,0 bar, 87 – 116 PSI
Air inlet connection	8 mm
Max. powder output	200 g/min
Operating temperature	5 – 45 °C, 41.0 – 113.0 °F
Weight	10,0 kg, 22.1 lb

### Included items

- Cup gun PEM-X1 CG
- Flat spray nozzle system
- Circular spray nozzle system
- Gun cable, 4m
- Mains cable
- Air hose package, 4m
- Control device EPG-Sprint X
- Non-return valves
- Wedge tool
- Funnel beaker with cover, 210 ccm
- Operating manuals (printed)

Product variants	Item no.	Price	PH 2
CupGun Set PEM-X1 CG	2328172		- -

## Powder set/Spraypack manual

The set consists of the central components for the installation of a powder coating system. A manual gun, a gun control unit, an injector, and a connection hose set ensure high-quality coating results.



Technical data	
Input voltage	85 – 250 V
Input power	40 W
Input frequency	47 – 440 Hz
Protection class	IP 64
Air inlet pressure	0,6 – 0,8 MPa, 6,0 – 8,0 bar, 87 – 116 PSI
Air inlet connection	8 mm
Operating temperature	5 – 45 °C, 41.0 – 113.0 °F
Weight	8,9 kg, 19.6 lb

Applying

Manual application systems

### Special advantages

- Corona manual gun with an air-flushed high-performance cascade  
Constant and reliable coating performance
- Ergonomic and perfectly balanced gun  
Continuous, pleasant working without tiring with a gun that only weighs 490 g
- Control unit with a regulated air volume cycle.  
A constant compressed air quantity despite fluctuations in the mains
- Fully electronic control module for repeatable results  
Saving and accessing up to 50 coating programs

### Processable materials

- Polyester powder coatings
- Epoxy powder coatings
- Metallic powder coatings
- Acrylic powder coatings
- UDS powder coatings
- Effect powder coatings

### Included items

- PEM-X1 Corona manual gun
- Flat or round jet nozzle package
- Control unit EPG Sprint X
- Power cable 3m
- Injector PI-F1
- Connection hoses
- Powder hose 5m (Ø 11mm)
- Ground cable 10 m
- Recipe sticker
- The gun and the control unit's printed OM

Product variants	Item no.	Price	PH 2
PrimaSprint manual set F incl. console	2313689		- -
PrimaSprint manual set incl. console	2313687		- -
Powderset PEM X1	2331090		- -
Powder Set PEM-X1 R	2335845		- -

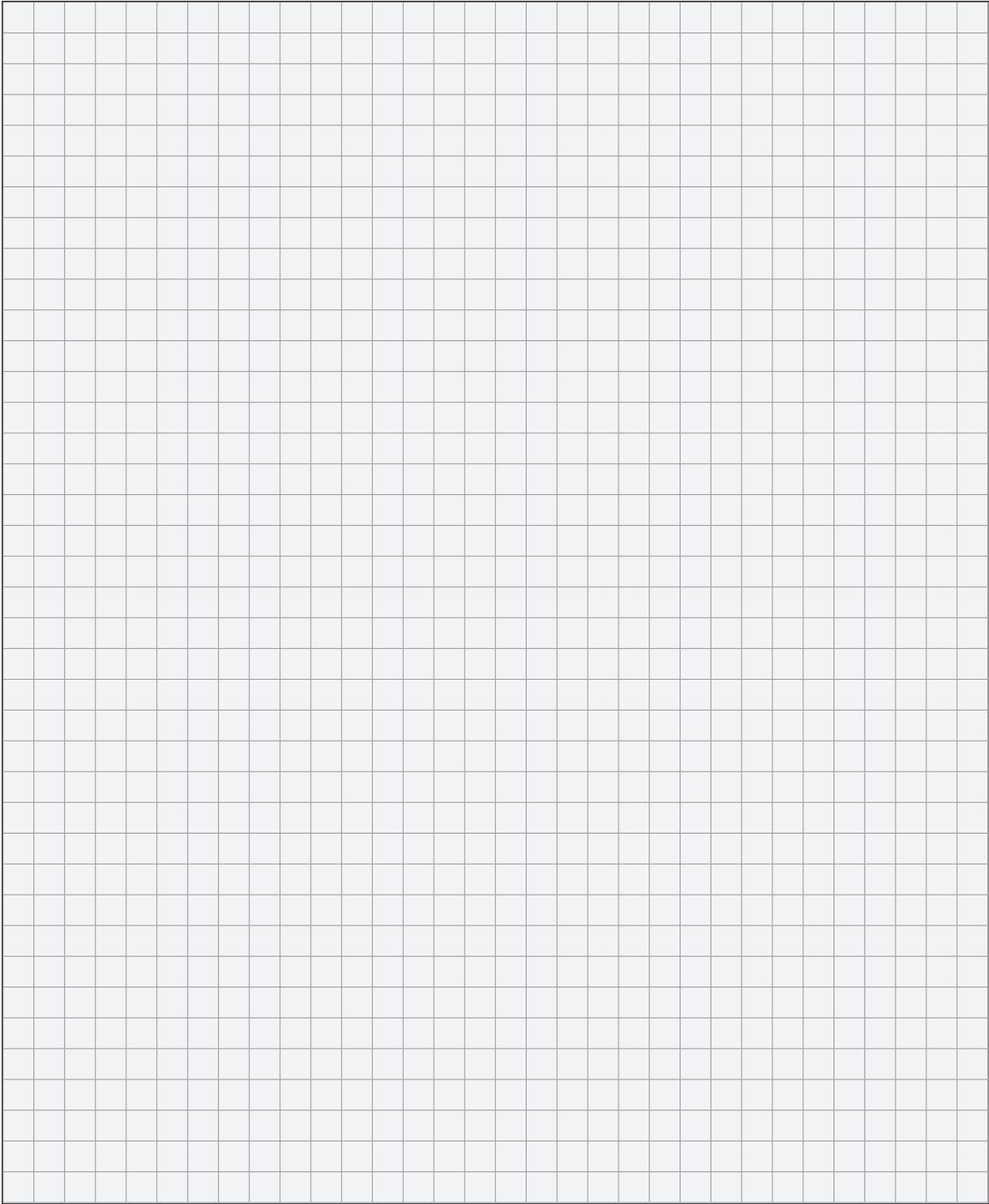

## Automatic application systems

Two types of WAGNER HiCoat automatic guns are available. The compact variant is designed for universal application. The XL variant was conceived specifically for paint change systems and is characterized by its streamlined design. Both guns are constructed for high coating output, high efficiency and a long service life. The high-performance HiCoat charging and atomization system can achieve perfect work piece surfaces combined with optimal material utilization.

### 1. Flexible Applications

The use of various nozzles allows for diverse applications of the automatic guns.

### 2. Quick Nozzle Change

The Quick Lock ensures a secure hold of the gun and allows for a quick nozzle change.

### 3. Maximum Application Efficiency

The use of the high-performance cascade offers maximum application efficiency and reduced powder consumption.

### 4. Optimum Geometry

The streamlined geometry ensures efficient automatic blowing-off during the automated paint change.

### 5. User Friendliness

The use of quick couplings ensures an easy hose change.

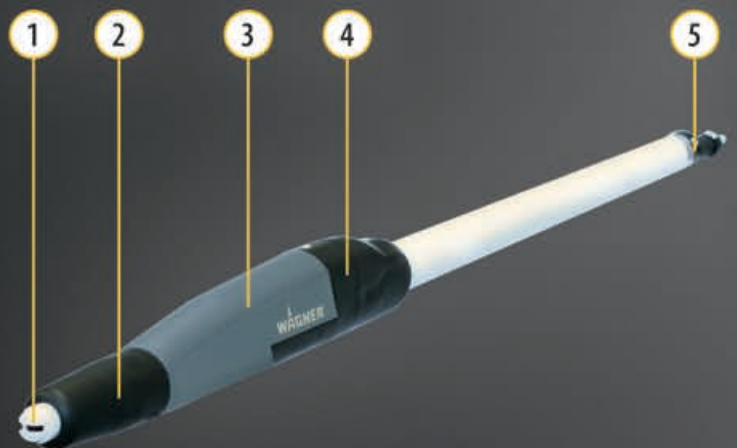



## Corona automatic guns

Corona automatic guns for automatic powder coating.



Technical data	
Max. input voltage	22 Vpp
Output voltage	100,0 kV
Polarity	Negative
Protection class	IP 54

### Special advantages

- Classification according to ignition energy class A  
Simple and inexpensive fire protection concept is adequate

### Processable materials

- Corona powder
- Commercially available metallic powders

### Controller

- PrimaTech-CCM
- ProfiTech

### Included items

- Gun
- Nozzle set

Product variants	Item no.	Price	PH 2
PEA-C4	390004		- -
PEA-C4 Enamel	390011		- -
PEA-C4XL 1.1	390006		- -
PEA-C4XL 1.4	390007		- -
PEA-C4 Twin	390010		- -

## Tribo automatic guns

Tribo automatic guns for automatic powder coating.



Technical data	
Polarity	Positive
Protection class	IP 54

Applying

Automatic application systems

### Special advantages

- Processes conventional powder types and metallic powders (if suitable for Tribo)  
Wide range of applications
- Charging body with multiple swirl stars  
Optimization of frictional charge over a broad range
- Tribo air for adjusting the charge  
Individual tuning of each gun to the particular application and powder

### Processable materials

- Tribo powder

### Controller

- Individual control unit
- Control cabinet module

### Included items

- Gun body assy.
- Nozzle system not included

Product variants	Item no.	Price	PH 2
PEA-T3	351018		- -
PEA-T3XL 1.4	351029		- -
PEA-T3XL 1.1	351030		- -

## Powder set/Spraypack automatic

Powder sets consist of the core components of application equipment, namely a control unit, guns, feed system and connection components.



Product variants	Item no.	Price	PH 2
Powderset Sprint automatic	2305139		- -
Powderset Sprint Tribo Automatic	2305140		- -

## High-voltage tester

High-voltage tester for measuring high voltage, for example of a gun.



Applying

Accessories

Product variants	Item no.	Price	PH 2
H.V.testers HV200 N	259010		- -

## Application accessories

Wagner offers a comprehensive accessories range for the application of powder lacquers. Please select the components you require from this table.

● Are compatible to each other

	PEM-X1 Corona manual gun	Cup-gun PEM-X1 CG	PEM-T3 Tribo hand gun	Manual system Sprint Airfluid	Manual system Sprint 60 l	Cup gun case set	PEA-C4	PEA-C4XL	PEA-C4 Twin	PEA-T3	PEA-T3 XL	Powder set/Spraypack manual	Powder set/Spraypack automatic	Powder set/Spraypack automatic		
<b>Nozzle systems</b>																
Nozzle Extension X1 EXT150	●	●													2323366	-
Nozzle Extension X1 EXT300	●	●													2323356	-
Nozzle Extension X1 EXT500	●	●													2323338	-
Electrode Holder X1 F	●	●													2322529	-
Flat Spray Nozzle X1 assy	●	●													2321976	-
Electrode Holder X1 R	●	●													2322490	-
Deflector cone sleeve X1	●	●													2320503	-
Deflector Cone D18 asse.	●	●													2321981	-
Deflector cone D25 asse.	●	●													2321980	-
Deflector Cone D34 assy	●	●													2321171	-
Electrode Holder with Round Nozzles X1	●	●													2322493	-
Round Nozzle Package X1 VL	●	●													2324148	-
Flat Spray Nozzle X1 VL	●	●													2324147	-
Deflector cone D22			●							●					259474	-
Deflector cone D28			●							●					259475	-
Wide Fan Spray Nozzle			●							●	●		●		260926	-
Nozzle Extension 300			●												260934	-
ELECTRODE HOLDER C4 F							●	●	●				●		390915	-
ELECTRODE HOLDER C4 R ET							●	●	●				●		390916	-
Fan Spray Nozzle F1							●	●	●				●		390324	-
Fan Spray Nozzle F2							●	●	●				●		390325	-
Fan Spray Nozzle F3							●	●	●				●		390326	-
Fan Spray Nozzle F4							●	●	●				●		2311889	-
Nozzle HP01							●	●							390331	-
Deflector cone							●	●	●				●		390207	-
Deflector cone							●								390208	-
Deflector cone							●								390209	-
ANGLE ADAPTER WA90 C4							●	●	●				●		390931	-
ANGLE ADAPTER WA60 C4							●	●	●				●		390930	-
ANGLE ADAPTER WA30 C4							●	●	●				●		390927	-
Angled nozzle 90° assy										●	●		●		260106	-
Tribalance 1700										●	●		●		259272	-
Deflector cone assy.D18 Tribo										●	●		●		260267	-
Deflector cone assy.D25 Tribo										●	●		●		260266	-
Deflector cone assy.D32 Tribo										●	●		●		260268	-
Split tip Tribo										●	●		●		260928	-
Finger nozzle 10x										●	●		●		260638	-
Finger nozzle 10x crosswise serration										●	●		●		260641	-
Finger nozzle 16x										●	●		●		260637	-
Finger Nozzle 16x crosswise										●	●		●		260642	-
Adapter finger nozzle 10-fach										●	●		●		260639	-

## Application accessories

Wagner offers a comprehensive accessories range for the application of powder lacquers. Please select the components you require from this table.

● Are compatible to each other

PEM-X1 Corona manual gun																				
Cup-gun PEM-X1 CG																				
PEM-T3 Tribo hand gun																				
Manual system Sprint Airfluid																				
Manual system Sprint 60 l																				
Cup gun case set																				
PEA-C4																				
PEA-C4XL																				
PEA-C4 Twin																				
PEA-T3																				
PEA-T3 XL																				
Powder set/Spraypack manual																				
Powder set/Spraypack automatic																				
Powder set/Spraypack automatic																				

Nozzule systems																						
Adapter 16 finger nozzle																			●	●	260648	-
Nozzle D10																			●	●	260518	-
Nozzle D8																			●	●	260519	-
Round Nozzle																			●	●	260505	-
Powder shower																			●	●	260504	-

Container																							
Powder Cup X1 210 ccm																			●	●	2324139	-	
5 Powder Cups X1 210 ccm																			●	●	2324140	-	
Powder Container 60 L without Injektor																					●	264268	-
Powder container 25 L																					●	264006	-
Powder container 60 L																					●	263089	-
Powder container 25 L -D1																					●	265031	-
Powder container 60 l -D1																					●	265033	-
Powderbox 3L assy.																					●	2304157	-

Connector, coupling																							
Hose Connector Assy D8-D10																				●	2322768	-	
Hose Connector Assy D10-D12																				●	2322761	-	
Hose adapter D8/10 ET																				●	390936	-	
Double connection 6/4																				●	3137409	-	
House Coupling XL2																				●	●	390954	-
Hose nozzle D10-D12																				●	●	390955	-
Hose nozzle d08-D10																				●	●	390956	-
Hose holder D10-D12 Rotatable																				●	●	390965	-
Adapter Nipple D10-12																				●	●	362316	-
Outer nut M18x1.5																				●	●	362317	-
Connecting part el. conductive																				●	●	2305865	-
Hose Holder D10-D12 el. conductive																				●	●	2305866	-
Hose Holder D08-D10 el. conductive																				●	●	2305867	-

Air hose																							
Tube black, D6																				●	●	9982079	-
Air-hose-5,5/8mm-PU-black																				●	●	9982078	-

Powder hose																							
Powder hose D10																				●	●	2310699	-
Powder hose D11																				●	●	2307502	-
Powder hose D12																				●	●	2310700	-
Powder hose D9																				●	●	351794	-
Powder hose D8																				●	●	351798	-

Measurement tools																							
Powder Measuring Bag (spare part)																				●	●	390940	-

## Application accessories

Wagner offers a comprehensive accessories range for the application of powder lacquers. Please select the components you require from this table.

● Are compatible to each other

	PEM-X1 Corona manual gun	Cup-gun PEM-X1 CG	PEM-T3 Tribo hand gun	Manual system Sprint Airfluid	Manual system Sprint 60 I	Cup gun case set	PEA-C4	PEA-C4XL	PEA-C4 Twin	PEA-T3	PEA-T3 XL	Powder set/Spraypack manual	Powder set/Spraypack automatic	Powder set/Spraypack automatic		
<b>Fixture</b>																
Gun holder for manual guns on cart	●	●	●	●	●	●						●			2330599	-
Gun-holder for manual cabins	●	●	●	●	●	●						●			2332139	-
adapter plate switchbox				●	●	●						●			2308079	-
Console EPG-Sprint X				●	●	●						●			2331558	-
Wallmount w. Console				●	●	●						●			2330223	-
Injector holder Sprint				●	●							●			2307117	-
Trolley Front Caster Set				●	●							●			2324869	-
Bracket f. short PEA guns							●			●			●	●	351347	-
Gun Extension							●	●		●	●		●	●	260215	-
Powder Hose Parking Station							●	●		●	●		●	●	351558	-
Antikinking XL-gun							●	●		●	●		●	●	351922	-
Antikinking corresponding XL 1-fold							●	●		●	●		●	●	351923	-
Antikinking corresponding XL 2-fold							●	●		●	●		●	●	373219	-
<b>Pick-up system</b>																
Suction tube ST550/10				●	●							●			265281	-
Suction Lance SN-2 550/10 Dual				●	●							●			265272	-
<b>Assembly</b>																
Protection hose PG 21							●	●	●	●	●		●	●	9998832	-
<b>Power cable</b>																
Connecting cable PEA-C2/C3/C4 5m				●	●	●	●	●	●	●	●	●	●	●	351216	-
Connecting cable PEA-C2/C3/C4 10m				●	●	●	●	●	●	●	●	●	●	●	351217	-
Connecting cable PEA-C2/C3/C4 20m				●	●	●	●	●	●	●	●	●	●	●	351215	-
Connecting cable PEA-T2 5m				●	●	●	●	●	●	●	●	●	●	●	351297	-
Connecting cable PEA-C2 10m				●	●	●	●	●	●	●	●	●	●	●	351296	-
Connecting cable PEA-C2 20m				●	●	●	●	●	●	●	●	●	●	●	351295	-
<b>Filter, maintenance</b>																
Filter Precipator				●	●	●						●			2305860	-
<b>Tools</b>																
Wedge tool X1 + 20 wedge's	●	●		●	●							●			2324124	-
Spare parts starter package Sprint	●	●		●	●							●			2331976	-
wedge tool C4 + 20 wedges							●	●	●						390900	-
Assembly Tool WA C4							●	●	●						390939	-
<b>Control</b>																
Controler EPG Sprint X	●	●	●	●	●	●	●	●	●	●	●	●	●	●	2324731	-
<b>Gun accessories</b>																
CoronaStar PEM-X1 assy	●	●	●	●	●							●			2322868	-

## Application accessories

Wagner offers a comprehensive accessories range for the application of powder lacquers. Please select the components you require from this table.

● Are compatible to each other

PEM-X1 Corona manual gun	Cup-gun PEM-X1 CG	PEM-T3 Tribo hand gun	Manual system SPRINT Airfluid	Manual system SPRINT 60 l	Cup gun case set	PEA-C4	PEA-C4XL	PEA-C4 Twin	PEA-T3	PEA-T3 XL	Powder set/Spraypack manual	Powder set/Spraypack automatic	Powder set/Spraypack automatic
--------------------------	-------------------	-----------------------	-------------------------------	---------------------------	------------------	--------	----------	-------------	--------	-----------	-----------------------------	--------------------------------	--------------------------------

Retrofit														
Dual Manual Set SPRINT	●			●									2331417	-
Accessories														
Wedge tool X1	●	●	●	●	●						●		2324205	-
Wedge X1	●	●	●	●	●						●		2320488	-
Retrofit														
Retrofit PRIMA SPRINT Airfluid			●	●							●		2309275	-
Conversion Set SPRINT 60L V			●	●							●		2309276	-
Conversion Set SPRINT 3L V			●	●							●		2309277	-
Control														
Switchbox			●	●							●		265911	-
Recipe Sticker			●	●	●						●	●	2331223	-
Accessories														
Protective wedge C4						●	●	●			●		390310	-
Gun accessories														
CoronaStar set PEM/PEA/PEA XL C4						●	●				●		390918	-
CoronaStar WA C4						●	●						2306335	-
Gun retrofit set														
Retrofit set for PEA-C2/C3 to C4 R						●					●		390922	-
Retrofit set for PEA-C2/C3 to C4 F						●					●		390905	-
Gun accessories														
MINI CORONA STAR ET						●	●				●		390957	-
Gun retrofit set														
Retrofit set for PEA-C2/C3 XL to C4 XL R							●						390923	-
Retrofit set for PEA-C2/C3XL to C4XL F							●						390906	-
Retrofit set for PEA-C2 Twin to C4 Twin								●					390925	-
Retrofit set for PEA-C2 Twin to C4 Twin								●					390908	-





# Fast color change for high efficiency.

A photograph of a Wagner powder booth in an industrial setting. The booth is white with a yellow "WAGNER" logo on the side. Inside, several yellow rectangular panels are hanging from the ceiling, illuminated from within. A metal railing is visible in the foreground.

Smaller space requirements coupled with greater performance and flexibility. These are features that distinguish WAGNER powder booth systems. Ranging from low-cost booth systems for entry-level applications and small operations to fully automatic powder coating units combined with pre- and post-coating, WAGNER has the right solution for a rapid paint change and the efficient use of powder. In combination with our recovery systems, we offer optimal energy and material efficiency to lower costs over the long term and protect the environment.



## Booths

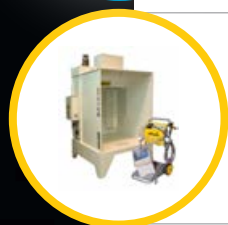

Manual booths

60

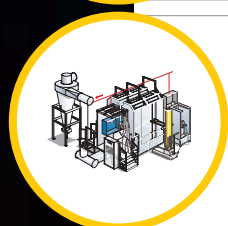

Automatic booths

66



Accessories

75

## Manual booths

The WAGNER manual booths not only offer an introduction to powder coating, but may also be integrated into automated systems. The BASIC line offers two cost efficient booth variants that customers may upgrade according to their requirements. Thanks to its numerous variants, the ID booth line may be employed for coating individual parts, for coating small volume productions and anything in between.

### 1. Flexibility

Here you find the right model for any coating requirements - be it for coating small or bulky parts.

### 2. Rapid Color Change

The comfortable handling of the work pieces in the easily accessible booth ensures efficient process steps.

### 3. Modern Booth Concept

Thanks to its compact design, the booth needs a relatively small installation surface. The booths include robust and scratch-resistant stainless steel floor tiles.

### 4. Easy and Safe Operation

From installation to setup, the WAGNER manual booths offer the easiest operation of all functions, for example ventilation and cleaning functions.

### 5. Energy Efficiency

The booth offers energy saving recirculated-air operation, the exhaust air is returned to the working area. The integrated exhaust system provides a dust free working environment.



## BASIC 4000 suspension booth

The BASIC 4000 suspension booth is suitable for the coating of individual parts or small series and is equipped with the basic functions required for a cost-effective system. It meets the technical requirements specified by CE and ATEX.



Technical data	
Input voltage	230 – 400 V
Rated power, drive motor	3,00 kW
Input frequency	50 Hz
Filter surface area	40 m <sup>2</sup> , 430,6 ft <sup>2</sup>
Number of filter cartridges	2
Air volume	4000 m <sup>3</sup> /h
Air consumption	25 Nm <sup>3</sup> /h

### Special advantages

- Coating opening (W x H) 1420 mm x 1420 mm  
Small footprint
- Optimal also for medium-sized to small parts  
Integrated rotatable workpiece suspension hook
- Integrated suction unit with 4000 m<sup>3</sup>/h  
Ergonomic and fatigue-free working conditions through direct accessibility to workpiece
- Connection for overspray collection bag below housing

### Included items

- Booth housing assy.
- Fan motor, not installed
- Silencer hood, not installed
- Two filter cartridges, not installed

Product variants	Item no.	Price	PH 2
Suspension Booth Basic 4000 left	3305080	-	-
Suspension Booth Basic 4000 right	3306210	-	-

## BASIC 8000 spray wall

The BASIC 8000 spray wall is suitable for the coating of large parts and is equipped with the basic functions required for a cost-effective system. It meets the technical requirements specified by CE and ATEX.



Technical data	
Input voltage	230 – 400 V
Rated power, drive motor	6,00 kW
Input frequency	50 Hz
Filter surface area	60 m <sup>2</sup> , 645,8 ft <sup>2</sup>
Number of filter cartridges	3
Air volume	8000 m <sup>3</sup> /h
Air consumption	25 Nm <sup>3</sup> /h

### Special advantages

- Suitable for integration in manual conveyor system  
Small space requirements
- Slanted air baffles for directing the air current  
Parts are directly accessible
- Compact size  
Low workpiece height
- Wide range of accessories

### Included items

- Back wall in 2 segments
- Fan motor, not installed
- Three baffles, not installed
- Silencer hood, not installed
- Three filter cartridges, not installed
- Mounting material

Product variants	Item no.	Price	PH 2
Spray wall BASIC 8000 left hand side	3301920		- -
Spray wall BASIC 8000 right hand side	3306211		- -

## ID transfer booth

The ID transfer booth is specially designed for the coating of small and large series in flow line operation.



### Special advantages

- Flow opening H=1530 mm x W=500 mm  
For workpieces up to H=1000 mm x B=300 mm
- Ceiling slots and inlet/outlet vestibules  
Integratable in automatic coating systems with flow line operation
- With stainless steel floor plate  
Robust, scratch resistant floor
- Booth on casters  
Mobile

### Included items

- Booth housing assy.
- Three filter cartridges
- Deflector grid

Technical data	
Input voltage	220 – 380 V
Rated power, drive motor	2,20 kW
Input frequency	50 Hz
Filter surface area	30 m <sup>2</sup> , 322,9 ft <sup>2</sup>
Number of filter cartridges	3
Air volume	4000 m <sup>3</sup> /h
Air consumption	20 Nm <sup>3</sup> /h

Product variants	Item no.	Price	PH 2
ID Run-Through Booth 3,5m Spray-to-Recov	3063837		--
ID Run-Through Booth 2,5m Spray-to-Recov	3056730		--
ID Run-Through Booth 2,5m Spray-to-Waste	3056770		--

## ID suspension booth

The ID suspension booth is designed specifically for small series with multiple colors.



Technical data	
Input voltage	220 – 380 V
Rated power, drive motor	2,20 kW
Input frequency	50 Hz
Filter surface area	30 m <sup>2</sup> , 322,9 ft <sup>2</sup>
Number of filter cartridges	3
Air volume	4000 m <sup>3</sup> /h
Air consumption	20 Nm <sup>3</sup> /h

### Special advantages

- Spray opening (W x H): 1440 mm x 1530 mm  
For workpieces up to W=800 mm x H=8000 mm
- Suspension hooks integrated in roof  
Reliable grounding of parts
- Base frame with stainless steel floor plate  
Robust, scratch resistant floor
- Booth on casters  
Mobile

### Included items

- Booth housing assy.
- Three filter cartridges
- Deflector grid

Product variants	Item no.	Price	PH 2
ID suspension booth for circulation mode	3057190		- -
ID suspension booth circul. mode + rail	3082406		- -
ID suspension booth spray-to-waste mode	3056720		- -



## ID spray wall

The ID spray wall is especially suited for the coating of large parts in one-color operation or for frequent color changes.



Technical data	
Input voltage	220 – 380 V
Rated power, drive motor	2,20 kW
Input frequency	50 Hz
Filter surface area	30 m <sup>2</sup> , 322,9 ft <sup>2</sup>
Number of filter cartridges	3
Air volume	4000 m <sup>3</sup> /h
Air consumption	20 Nm <sup>3</sup> /h

### Special advantages

- Slanted air baffles for directing the air current  
Integratable in automatic coating systems with flow line operation
- Base frame with stainless steel floor plate  
Robust, scratch resistant floor
- Booth on casters  
Mobile

### Included items

- Spray wall assy.
- Three filter cartridges
- Deflector grid

Product variants	Item no.	Price	PH 2
ID Spraywall Spray-to-Recovery	3057870		- -
ID Spraywall Spray-to-Waste	3057905		- -

## Automatic stainless steel booths

Stainless steel booths are used where an automatic coating system needs to be built on a small budget and in a rough environment. This indestructible and easy-to-maintain booth type ensures professional use over many years. With the ICF (filter) and ICM (multicyclone) recovery versions, units can be built for single paint or multi-paint systems.

### 1. Easy cleaning

The accessible stainless steel booth floor and the smooth surfaces ensure efficient cleaning.

### 2. Cost-effectiveness and efficiency

Variable suction capacity thanks to the modular combination of recovery modules.

### 3. Modular design

Thanks to the modular and compact design the booth may be adapted easily to the users requirements.

### 4. Optimal process sequences

The booths offer integrated manual coating stations with optimal positioned illumination.

### 5. Process reliability

No sintering when directly connected to the multicyclone.

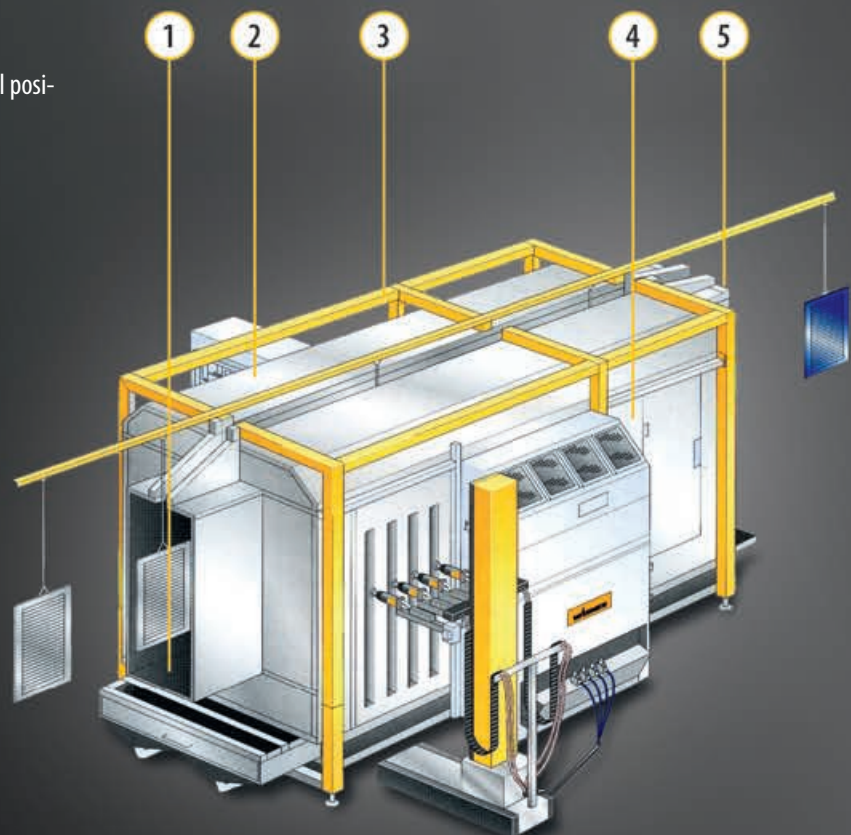

## ICM multicyclone booths

ICM Integral Compact Multicyclone stainless steel booths are designed for automatic powder coating and manual coating in multipaint operation.

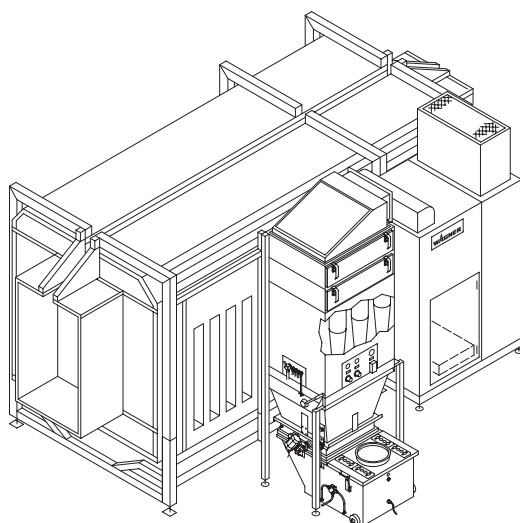

### Special advantages

- Booth housing and treadable booth floor of stainless steel  
Easy-to-clean surfaces
- Robust steel frame support structure  
Sturdy, indestructible construction
- Variable suction capacity through modular combination of recovery modules at 8000 m<sup>3</sup>/h and higher  
Small footprint and low equipment height
- Fluid container with integrated sieve, directly equipped with injectors for optimum coating quality  
Attractive price

### Ordering information

- ICM multicyclone booths are configured to meet individual customer requirements.
- The WAGNER engineering department will make an offer on request within a very short period of time.

## ICF filter booths

ICF Integral Compact Filter stainless steel filter booths are designed for automatic powder coating and manual coating for up to 3 colors.

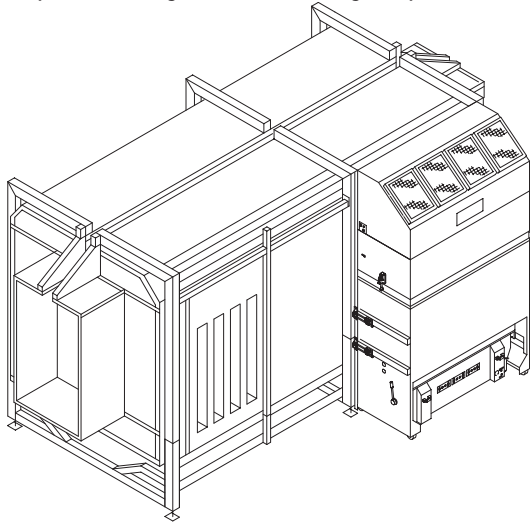

### Special advantages

- Booth housing and treadable booth floor of stainless steel  
Easy-to-clean surfaces
- Robust steel frame support structure  
Sturdy, indestructible construction
- Variable suction capacity through modular combination of recovery modules at 8000 m<sup>3</sup>/h and higher  
Small footprint and low equipment height
- Fluid container with integrated sieve, directly equipped with injectors for optimum coating quality  
Attractive price

### Ordering information

- ICF filter booths are configured to meet individual customer requirements.
- The WAGNER engineering department will make an offer on request within a very short period of time.

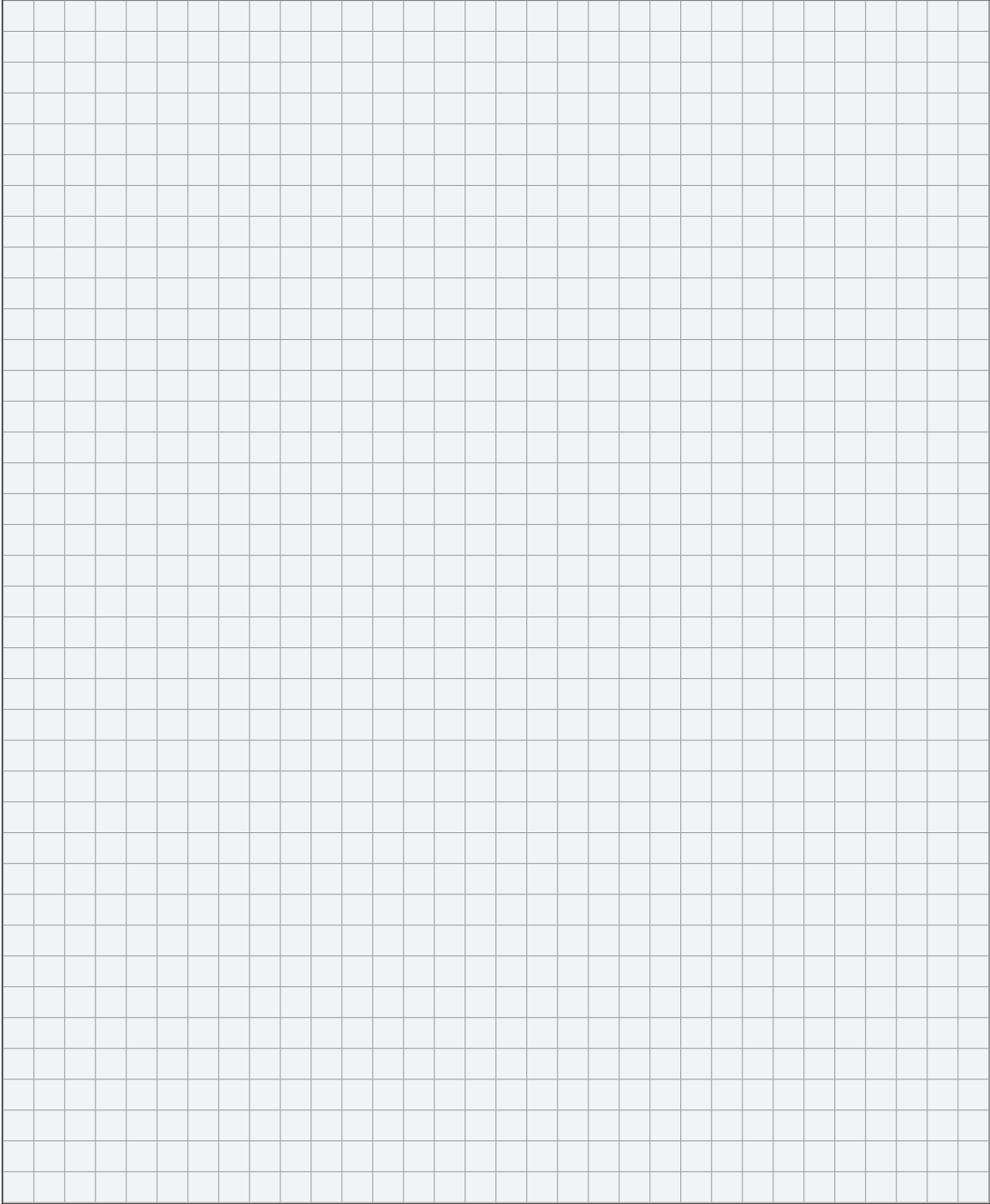

## Automatic plastic booths

Today automatic plastic booths are mainly used in modern powder coating systems. The material PVC is particularly suited for the construction of a complete HiCoat system, thanks to its mechanical properties (robust, repairable), but also especially thanks to its electrostatic properties. Depending on recovery system single-paint systems with filter recovery or multi-paint systems with monocyclone recovery can be constructed. Here it has been proven that paint changes only take a few minutes. Today these multi-paint systems are used for all contract coating companies.

### 1. Excellent Coating Results

There is no paint carry-over thanks to the optimized pipe geometry. This ensures a safe change for critical powders.

### 2. Rapid Paint Change

An efficient paint change is ensured thanks to the compact design of the booth housing and the powder repulsion.

### 3. Optimal Booth Cleaning

Booth housings with PVC sandwich construction are dust repellent (no sintering).

### 4. Maximum Pressure Electrode Effect

This ensures an increased application efficiency.

### 5. Consistent Powder Quality

The prevention of separation during powder circulation ensures a consistently high powder performance during the coating process.

### 6. High Application Efficiency.

The even suction for the complete booth length allows for an optimal surface quality.

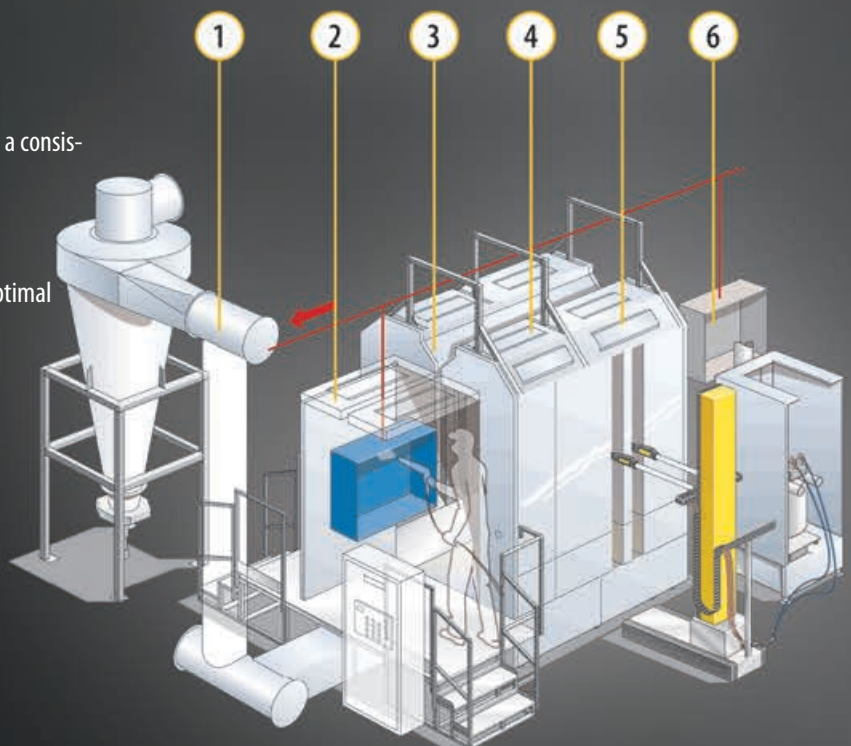

## PrimaCube plastic booths

The booth is made of PVC sandwich elements and provides the basis for a quick paint change system. Two model sizes with manual coater station and practical accessories allow for the individual and universal use in a wide range of applications.

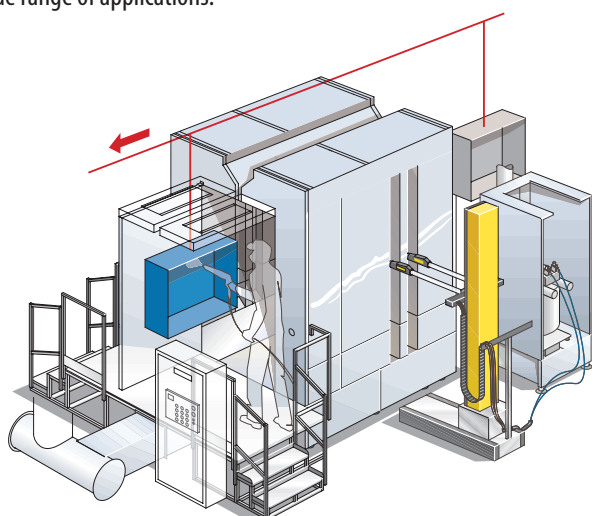

### Special advantages

- Booth housing with PVC sandwich construction  
Rapid and easy paint change, partially automated (dependent on configuration)
- Short booth, only 2,5 m long  
Very low powder quantities in the cycle for consistently high quality coating results
- Manual coater located at the front  
Direct access to workpiece ensures very high coating quality
- Walk-in booth  
Access to all locations

### Ordering information

- Automatic booths are configured to meet individual customer requirements.
- The WAGNER engineering department will make an offer on request within a very short period of time.

Product variants	Item no.	Price	PH 2
Booth package PrimaCube 12000	2331525		- -
Booth package PrimaCube 16000	2313690		- -

## SuperCube plastic booths

The SuperCube allows a quick paint change without entering the booth. The PVC sandwich booth design offers an even flow distribution for the highest application efficiency during coating.

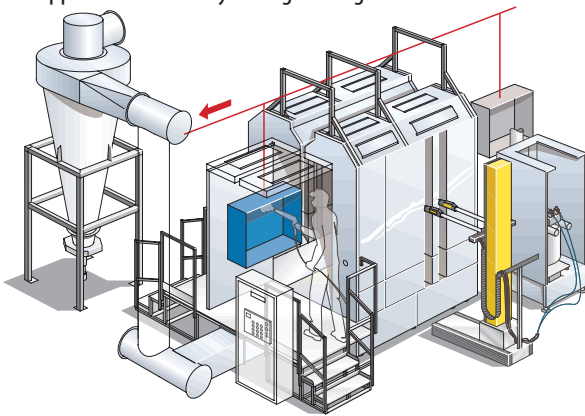

### Special advantages

- Booth housing with PVC sandwich construction  
Very rapid and simple paint change, partially automated (depends on configuration)
- Short booth, only 2,5 m long  
Very low powder quantities in the cycle for consistently high quality coating results
- Manual coater located at the front  
Direct access to workpiece ensures very high coating quality
- Walk-in booth  
Access to all locations

### Ordering information

- SuperCube plastic booths are configured to meet individual customer requirements
- The WAGNER engineering department will make an offer on request within a very short period of time



## SuperTech plastic booths

The booth is a version of the SuperCube. Manual coaters can be arranged at the front or on the sides. The number of gun slots is individual. Vertical and horizontal gun arrangement is possible.

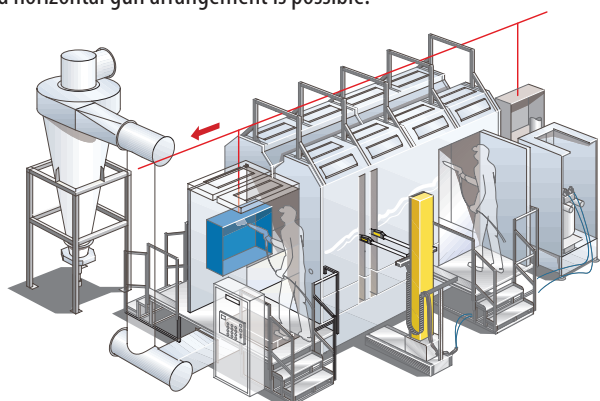

### Special advantages

- Booth housing with PVC sandwich construction  
Very rapid and simple paint change, partially automated (depends on configuration)
- Booth length is variable to 7.5 m, 1-6 gun slots per side, universal arrangement options for manual coater stations  
Short design
- Manual coater at the front or on the sides  
Optimal arrangement ensures excellent coating results
- Walk-in booth  
Access to all locations

### Ordering information

- SuperTech plastic booths are configured to meet individual customer requirements
- The WAGNER engineering department will make an offer on request within a very short period of time

## Customized booths

Wagner has extensive know-how in building booths for any workpiece size, ranging from door handles to semitrailers. The particular requirements in each case call for specific gun arrangements, motion systems and process flows



### Special advantages

- Customized booths designed to meet individual customer requirements  
Fulfilling customer specifications

### Ordering information

- Customized powder booths are tailored to individual needs
- The WAGNER engineering department will make an offer on request within a short period of time

## Booth accessories

Wagner offers a comprehensive accessories range for powder booths. Please select the components you require from this table.

● Are compatible to each other

BASIC 4000 suspension booth	BASIC 8000 spray wall	ID transfer booth	ID suspension booth	ID spray wall	ICM multicyclone booths	ICF filter booths	PrimaCube booth system	SuperCube plastic booths	SuperTech plastic booths	Customized booths
-----------------------------	-----------------------	-------------------	---------------------	---------------	-------------------------	-------------------	------------------------	--------------------------	--------------------------	-------------------

Container												
Collector tank			●	●	●						3055950	-
Powder trolley assy. ID 1 Injector			●	●	●						3104860	-
Powder trolley assy. ID 2 Injectoren			●	●	●						3105976	-
Powder trolley, no lid						●					3150742	-
Vibrator drive assy. IMZ						●					3101339	-
Damping chamber assy.						●					3134640	-
Container lid 1-4 Inj. assy.						●					3310770	-
Container lid 1-8 Inj. assy.						●					3310771	-
Container lid 1-12 Inj. assy.						●					3310772	-
Container lid 1-16 Inj. assy.						●					3310773	-
Powder collectn cont.assy						●					3067000	-
Powder trolley 1-4 Inj.							●				3310775	-
Powder trolley 1-8 Inj.							●				3310776	-
Powder trolley 1-12 Inj.							●				3310777	-
Powder trolley 1-16 Inj.							●				3310778	-
Mixed powder trolley							●				3054065	-
Powder Container PrimaCenter								●			3918797	-
Air hose												
spiralhose PVC grey d150								●			2312326	-
Pick-up system												
Pick-up table ICM/ICF compl.						●	●				3310754	-
Spacer 5mm for injector connection IC						●	●				3310753	-
Blow-out system												
Injector retainer plate 4-fold						●					3103200	-
Blind injector						●					701452	-
Assembly												
Sealing plug						●	●				3306622	-
Lock nut M20x1.5							●				3156833	-
Power cable												
Ground wire						●	●				3105965	-
Filter												
Filter cartridge KE 2766 TI 15-20	●	●						●	●	●	3159587	-
Filter cartridge K E276 9TI 15-10			●	●	●	●					3131045	-
Filter cartridge KE 2768 TI 15-10						●					3131046	-
Viledon-Filter mat						●					3100027	-
Filter cartridge KE 2767 TI 15-10							●				3131047	-
Filter cartridge KE 2765 TI 15-16							●				3131048	-
Filter cartridge Ultraweb, grounded								●	●	●	2338860	-

## Booth accessories

Wagner offers a comprehensive accessories range for powder booths. Please select the components you require from this table.

● Are compatible to each other

BASIC 4000 suspension booth	BASIC 8000 spray wall	ID transfer booth	ID suspension booth	ID spray wall	ICM multicyclone booths	ICF filter booths	PrimaCube booth system	SuperCube plastic booths	SuperTech plastic booths	Customized booths
-----------------------------	-----------------------	-------------------	---------------------	---------------	-------------------------	-------------------	------------------------	--------------------------	--------------------------	-------------------

Filter												
Filter cartridge Wagner-Donaldson							●	●	●	●	2341742	-
Filter cartridge							●	●	●	●	2315642	-
Sieve												
Strainer chamber assy. IMZ						●					3106026	-
Sieving chamber 315qmm assy						●					3069260	-
Vibrat. screen assy. IC-3							●				3059011	-
Noise reduction												
Silencer hood ID top assy.			●	●	●						3058017	-
Blow out silencer						●					3140958	-
Silencer hood assy.						●					3103049	-
Blow-off system												
Blower gun	●	●	●	●	●	●	●	●	●	●	3920048	-
Nozzle essay just with clutch.	●	●	●	●	●	●	●	●	●	●	3920053	-
Hose rell assy.	●	●	●	●	●	●	●	●	●	●	3923136	-
Link nozzle 40mm						●	●	●	●	●	3303641	-
Extension for blowing gun 460mm						●	●	●	●	●	3921960	-
Extension for blowing gun 960mm						●	●	●	●	●	3920051	-
Extension for blowing gun 1460mm						●	●	●	●	●	3920052	-
Extension for blowing gun 1960mm						●	●	●	●	●	3923041	-
Extension for blowing gun 2500mm						●	●	●	●	●	3927555	-
Extension for blowing gun 3000mm						●	●	●	●	●	3927556	-
Cleaning nozzle for conveyor protector						●	●	●	●	●	3923043	-
Slot Cleaning Brush						●	●	●	●	●	3307849	-
Cleaning tools												
Multitexrolle in pickbox	●	●	●	●	●	●	●	●	●	●	3311137	-
Cleaning sponge						●	●				3107449	-
Blower lance cpl.						●	●				3107643	-
Rubber scraper						●	●				3107454	-
Scraper						●	●				3107456	-
Plasticgranulate cyclonecleaning								●	●	●	3310593	-
Accessorie												
roller set for Basic 4000	●										3306110	-
movable profil frame assy. for Basic 800		●									3306133	-
small ground panel Basic 8000		●									3305528	-
big ground panel Basic 8000		●									3305529	-
Accessories												
Covering shoes						●	●	●	●	●	3301015	-
Filter trolley assy. 8000m <sup>3</sup> /h							●				3059060	-

## Booth accessories

Wagner offers a comprehensive accessories range for powder booths. Please select the components you require from this table.

● Are compatible to each other

	BASIC 4000 suspension booth	BASIC 8000 spray wall	ID transfer booth	ID suspension booth	ID spray wall	ICM multicyclone booths	ICF filter booths	PrimaCube booth system	SuperCube plastic booths	SuperTech plastic booths	Customized booths			
<b>Accessories</b>														
Filter trolley assy. 12000m <sup>3</sup> /h							●					3060002	-	
PrimaCenter integral								●				2330014	-	
Reduction sleeved10								●				241580	-	
Flat seal								●				241581	-	
PrimaCube-manual platform 16.000								●				2312608	-	
PrimaCube-MC-Roof, additional								●				2312607	-	
PrimaCube-manual platform 12000								●				2329939	-	

## Strong performance ensures a perfect environmental balance.

WAGNER recovery systems separate the powder/air mixture exhausted from the booth and return the powder to the powder circuit. WAGNER offers two different systems: filter and cyclone recovery.





## Recovery

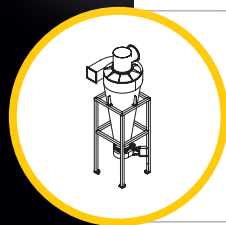

Cyclones

80

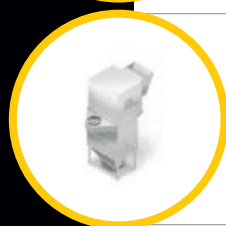

Filter

82



Accessories

88

## Multicyclone

Multicyclone units are used as a powder recovery system in Wagner IC stainless steel booths. They are characterized by their compact design and high separation efficiency.

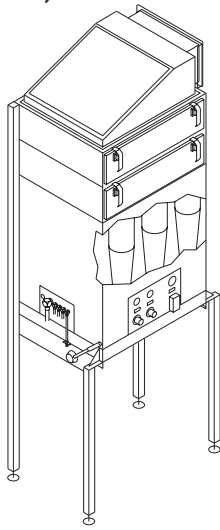

Technical data	
Operating temperature	5 – 45 °C, 41.0 – 113.0 °F
Weight	400,0 kg, 882.0 lb

### Special advantages

- Compact size  
Small space requirements
- High removal efficiency  
Low waste volume in after-filter
- Usable with suction capacities from 8000–12000 m<sup>3</sup>/h  
High specific suction capacity

### Processable materials

- Corona powder
- Tribo powder
- Commercially available metallic powders

### Included items

- Multicyclone box with 9 minicyclones
- Pipe not included
- After-filter not included
- Powder container not included

Product variants	Item no.	Price	PH 2
Multicyclone Unit	3100315		-



## Monocyclone

The monocyclone is used with automatic booths in paint change systems. It separates the powder/air mixture sucked out of the booth. The exhaust passes to the final filters via a pipe. The sieved powder is returned to the guns.

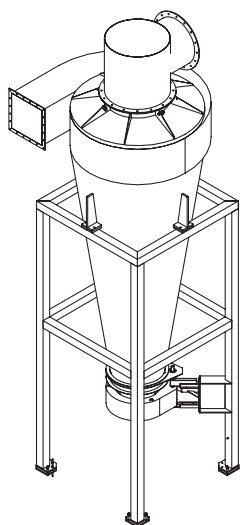

### Technical data

Air inlet pressure	0,6 – 0,8 MPa, 6,0 – 8,0 bar, 87 – 116 PSI
Operating temperature	5 – 45 °C, 41.0 – 113.0 °F

### Special advantages

- High removal efficiency at approx. 95% depending on powder and powder load  
Minimal powder waste
- Cyclone hopper with two-hand control  
Meets safety requirements

### Processable materials

- Corona powder
- Tribo powder
- Commercially available metallic powders

### Included items

- Monocyclone with frame
- Powder extraction with two-hand control
- Vibration sieve 400 µm
- Peristaltic conveyor not included
- Pipe not included
- After-filter not included

Product variants	Item no.	Price	PH 2
Cyclone box complete 8000m <sup>3</sup> /h, left	2303371		--
Cyclone box 12000m <sup>3</sup> /h, left	3301416		--
Cyclone box 16000m <sup>3</sup> /h, left	3301175		--
Cyclone box 20000m <sup>3</sup> /h, left	3301177		--
Cyclone box 24000m <sup>3</sup> /h, left	3301968		--
Cyclone box complete 8000m <sup>3</sup> /h, right	3313189		--
Cyclone box 12000m <sup>3</sup> /h, right	3301417		--
Cyclone box 16000m <sup>3</sup> /h, right	3301176		--
Cyclone box 20000m <sup>3</sup> /h, right	3301178		--
Cyclone box 24000m <sup>3</sup> /h, right	3301969		--

## After-filter unit, ICM multicyclone

Final filters are required to operate a cyclone system. They provide the necessary suction capacity and must be matched to the pressure loss in the overall system.

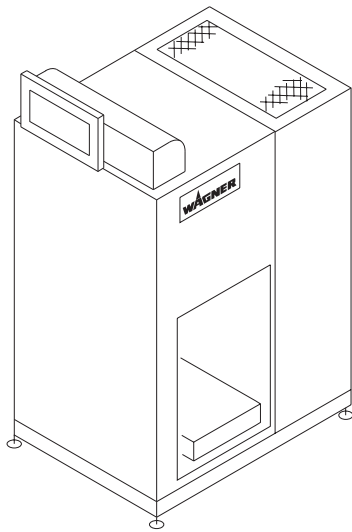

Technical data	
Filter surface area	120 m <sup>2</sup> , 1.291,7 ft <sup>2</sup>
Air inlet pressure	0,6 – 0,8 MPa, 6,0 – 8,0 bar, 87 – 116 PSI
Blow direction	Upward
Three-phase current connection	220–240 / 380–420 V
Number of filter cartridges	12
Air consumption	15 Nm <sup>3</sup> /h
Operating temperature	5 – 35 °C, 41.0 – 95.0 °F
Max. sound level	82 dB(A)

### Special advantages

- Filter cartridges, application categories U, S, G, C  
Meet the legal requirements for powder removal
- Filter cleaning with compressed air pulses  
Low air consumption
- Differential pressure monitor  
Maintain the minimum suction capacity

### Suitable for product

- ICM multicyclone

### Included items

- Filter unit with powder collecting container
- Fan unit
- Vent silencer not included

Recovery

Filter

Product variants	Item no.	Price	PH 2
Filter modul ICM 8000m <sup>3</sup> /h cpl.	3140956		- -
Filter modul ICM 10000m <sup>3</sup> /h cpl.	3140957		- -
Filter modul ICM 12000m <sup>3</sup> /h kpl.	3304378		- -

## After-filter unit , monocyclones

Final filters are required to operate a cyclone system. They provide the necessary suction capacity and must be matched to the pressure loss in the overall system.



Technical data	
Air inlet pressure	0,6 – 0,8 MPa, 6,0 – 8,0 bar, 87 – 116 PSI
Three-phase current connection	220–240 / 380–420 V
Air consumption	15 Nm <sup>3</sup> /h
Operating temperature	5 – 35 °C, 41.0 – 95.0 °F

### Special advantages

- Filter cartridges, application categories U, S, G, C  
Meet the legal requirements for powder removal
- Filter cleaning with compressed air pulses  
Low air consumption
- Differential pressure monitor  
Maintain the minimum suction capacity
- Horizontal filter cartridges  
Easy to maintain and replace

### Suitable for product

- Monocyclone

### Included items

- Filter unit with powder collecting trolley
- Fan unit
- Vent silencer
- Filter control unit

Product variants	Item no.	Price	PH 2
Filterunit 3DFP9-8000-R	2331487		- -
Filterunit 4DFP12-12000-R	2331488		- -
Filterunit 4DFP16-16000-R	2331489		- -
Filterunit 4DFP16-20000-R	2331490		- -
Filterunit 4DFP24-24000-R	2331491		- -
Filterunit 4DFP32-28000-R	2331492		- -
Filterunit 4DFP32-32000-R	2338865		- -
Filterunit 3DFP9-8000-L	2331494		- -
Filterunit 4DFP12-12000-L	2331495		- -
Filterunit 4DFP16-16000-L	2331496		- -
Filterunit 4DFP16-20000-L	2331497		- -
Filterunit 4DFP24-24000-L	2331498		- -
Filterunit 4DFP32-28000-L	2331499		- -
Filterunit 4DFP32-32000-L	2338866		- -

## ICF filter recovery

The filter is used to separate coating powders directly. It is characterized by a very high separation efficiency of over 99.9%. The ICF system can be flange-mounted directly onto the booth. The mobile filter trolley can be readily exchanged during a paint change.

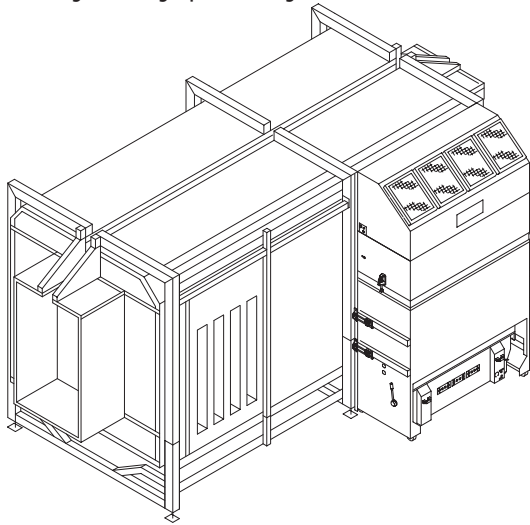

### Special advantages

- Compact set up with sieving unit and fluidized container  
Less space requirements, good cost/performance ratio

## ICF filter recovery – air outlet box

The sound-insulated air outlet box collects the air that is sucked in and blown out by the fans and returns it to the environment

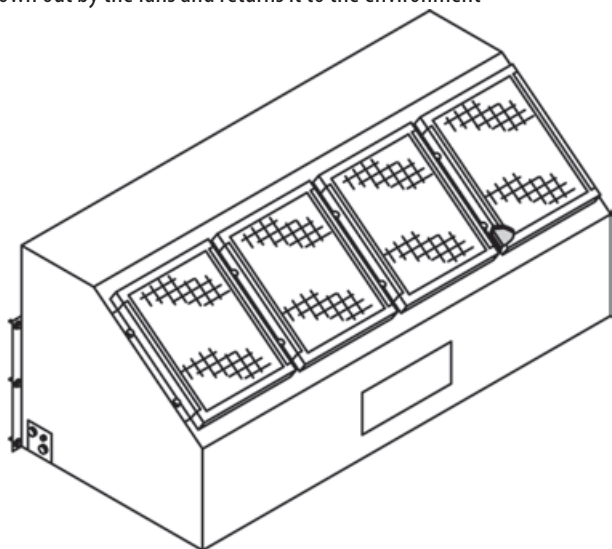

### Technical data

Blow direction	Upward
----------------	--------

### Special advantages

- Flange-mounted directly onto the booth hull
- Space-saving construction

### Included items

- Air outlet box
- Sound insulation elements

Product variants	Item no.	Price	PH 2
Air outlet box assy. 8000m <sup>3</sup> /h	3059080		- -
Air outlet box assy. 12000m <sup>3</sup> /h	3059990		- -

## ICF filter recovery – fan box

The fan box allows for a certain suction capacity of a booth. If the pressure loss in the air system is known, the expected air power can be calculated on the basis of the fan characteristic curves. It is optimally coordinated with the ICF system.

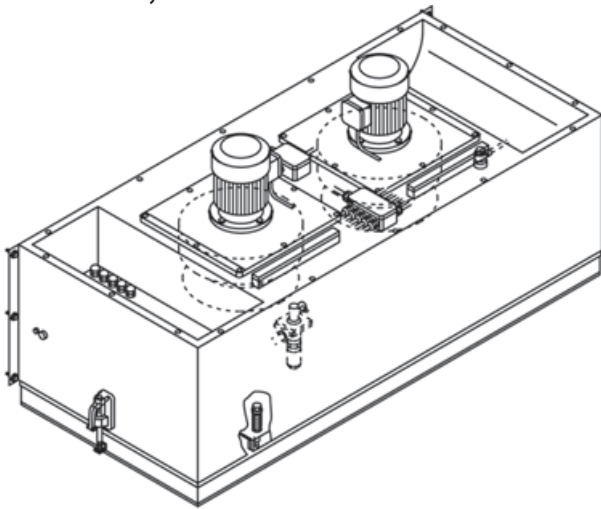

Technical data	
Air inlet pressure	0,6 – 0,8 MPa, 6,0 – 8,0 bar, 87 – 116 PSI
Three-phase current connection	220–240 / 380–420 V
Max. sound level	78 dB(A)

### Special advantages

- Flange-mounted directly onto the booth hull
- Space-saving construction

### Included items

- Fan box
- Two air motors
- Two radial fan wheels
- Ten pulse cleaning valves

Product variants	Item no.	Price	PH 2
Fan box with cleaning 8000m <sup>3</sup> /h	3059100		-
Fan box with cleaning 12000m <sup>3</sup> /h	3059980		-

## Filter trolley

The powder/air mixture sucked in from the booth is separated in the filter trolley. The powder is captured in the ribs and is cleaned off by compressed air impulses. The recovered powder may thus be returned to circulation.

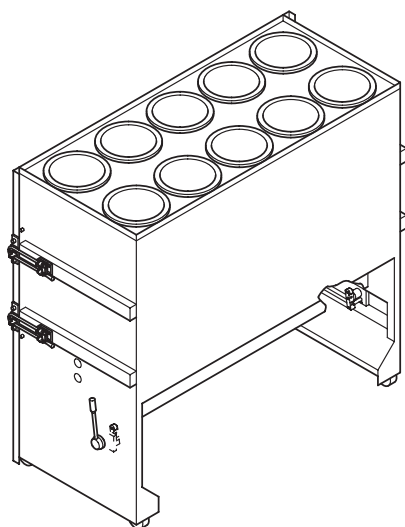

### Technical data

Air inlet pressure	0,6 – 0,8 MPa, 6,0 – 8,0 bar, 87 – 116 PSI
Number of filter cartridges	10

### Special advantages

- Filter cartridges, application categories U, S, G, C  
Meet the legal requirements for powder removal
- Large filter opening  
Minimal pressure loss
- Flange-mounted directly onto the booth  
Space-saving construction
- Considered to be an open recovery system  
Does not require a flame arrestor for fire protection

### Included items

- Filter box with insertion opening for powder container
- Ten filter cartridges

Product variants	Item no.	Price	PH 2
Filter trolley assy. 8000m <sup>3</sup> /h	3059060		- -
Filter trolley assy. 12000m <sup>3</sup> /h	3060002		- -

## Recovery accessories

WAGNER offers a comprehensive accessories range for the recovery of powder lacquers. Please select the components you require from this table.

● Are compatible to each other



Filter	After-filter unit, ICM multicyclone	After-filter unit, monocyclones	Filter trolley			
Filter cartridge K E276 9TI 15-10	●			3131045	-	
Filter cartridge KE 2768 TI 15-10	●			3131046	-	
Viledon-Filter mat	●			3100027	-	
Filter cartridge Ultraweb, grounded		●		2338860	-	
Filter cartridge KE 2767 TI 15-10			●	3131047	-	
Filter cartridge KE 2765 TI 15-16			●	3131048	-	



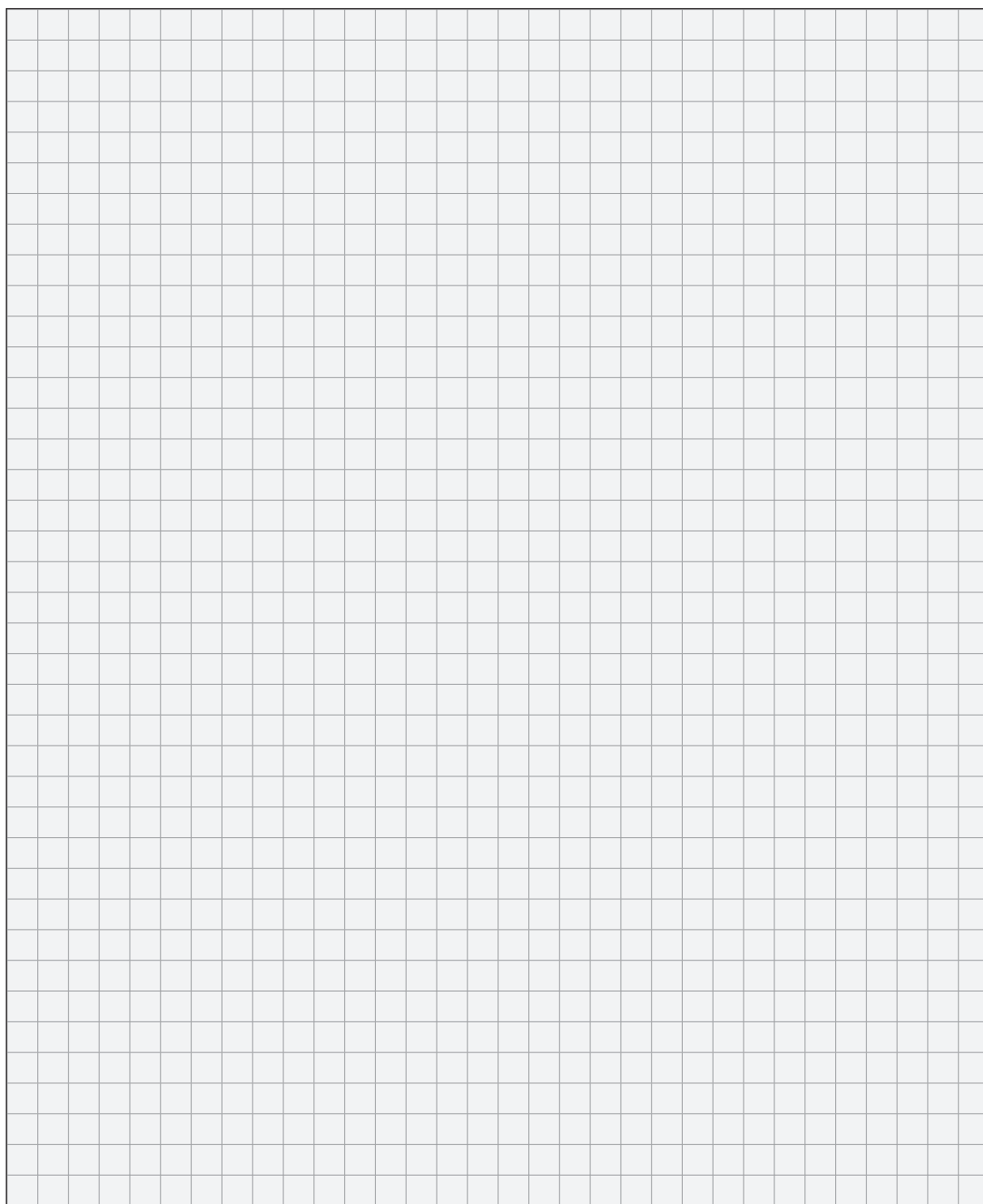

## Highly dynamic for highest flexibility.

The coating of complex parts such as the inside of cabinets require guns to move independently from each other. WAGNER offers various systems ranging from simple linear units to dynamic 3D coating with Z-axes. Thus, efficient coating can be achieved without investing in an expensive robot.



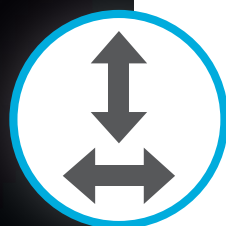

## Moving

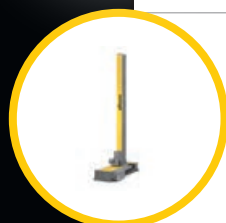

Linear units

92



Accessories

102

## Vertical movement system

The motion technology is flexibly applicable. Whether long or short strokes, with this technology any motion sequence can be executed with precision. The horizontal sliding table allows for complex motions and thus ensures the coating of complex parts.



Technical data	
Input voltage	230 – 400 V
Rated power, drive motor	0,75 kW
Input frequency	50 – 50 Hz
Protection class	IP 54
Ambient temperature	0 – 45 °C, 32 – 113 °F
Max. load capacity of device support	30 kg
Ascent and descent speed	6 – 30 m/min

### Special advantages

- Flexible application  
A device for both long and short stroke applications and as a positioning device
- Intelligent drive concept  
Ensures precise and durable path measurement with an intelligent frequency converter
- Stable mechanical construction  
Lightweight, but robust design thanks to aluminium sections and clearance free precision linear guiding and ball cages.
- Maintenance-friendly drive concept  
Wire-enforced toothed belt ensures a long service life

### Controller

- MCS 1 (Stand-alone-mode)
- PrimaTech
- ProfiTech M
- ProfiTech S

Product variants	Item no.	Price	PH 2
Vertical Moving Device VU 1-1800	2327615		- -
Vertical Moving Device VU 1-2400	2327616		- -
Vertical Moving Device VU 1-3000	2327617		- -

## Horizontal movement system

The system is a precise and stable sliding table with a drive unit that, after a reference run, is able to determine and move to the exact position at any time. An ideal solution for the safe and reliable positioning of reciprocators.

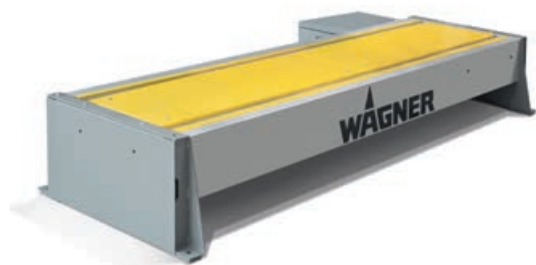

Technical data	
Input voltage	230 – 400 V
Rated power, drive motor	0,18 kW
Input frequency	50 – 50 Hz
Protection class	IP 55
Ambient temperature	0 – 45 °C, 32 – 113 °F
Max. in/out positioner load	450 kg, 15.873,3 oz
Displacement speed	6 m/min
Width	600 mm, 23.6 in
Height	282 mm, 11.1 in

### Special advantages

- Intelligent drive concept  
Ensures a precise and long-life displacement measurement with an intelligent frequency converter
- Stable mechanical construction  
Lightweight, but robust design thanks to aluminium sections and precision linear guiding and ball cages.
- Maintenance-friendly drive concept  
Wire-enforced toothed belt ensures a long service life
- Low-vibration movement processes  
Stable mechanical construction ensures a stable powder cloud thus ensuring optimal coating results

### Controller

- MCS 1 (Stand-alone-mode)
- PrimaTech – CCM
- ProfiTech S
- ProfiTech M

Product variants	Item no.	Price	PH 2
Horizontal moving device HU 1-600	2327619		- -
Horizontal moving device HU 1-1000	2335048		- -
Horizontal moving device HU 1-1200	2327621		- -
Horizontal moving device HU 1-1600	2327622		- -
Horizontal moving device H 1-600 M	2327623		- -
Horizontal moving device H 1-1000 M	2336456		- -
Horizontal moving device H 1-1200 M	2327625		- -

## Roller set RS 8

Manual slide unit for horizontally positioning the reciprocators and setting the distance of the gun to the workpiece.



### Special advantages

- Stable U profile frame  
Simple, solid technology
- Base plate with 4 flanged rollers  
Highly durable

Product variants	Item no.	Price	PH 2
Roller set RS 8-600	2327628		- -
Roller set RS 8-1000	2337074		- -
Roller set RS 8-1200	2327630		- -

## Z-axes

Z-axes are used for moving individual guns in a straight line. Generally, one Z-axis is used per gun. In addition, Z-axes are used as positioning axes for gun groups or other axes.



Technical data	
Protection class	IP 54
Ambient temperature	0 – 40 °C, 32 – 104 °F
Speed	30 m/min

### Special advantages

- Modular system with varying travel distances and loads  
Individual configuration depending on application
- High positioning accuracy  
Reproducible settings
- Compact size  
Small space requirements
- Combination of several axes possible  
Simple assembly of a coating robot

### Controller

- ProfiTech S

### Ordering information

- Z and positioning axes are individually sized to meet customer requirements.
- The WAGNER project division will make an individual offer upon request

## Rotary axes

Rotary axes are used to rotate the gun around its longitudinal axis.



### Special advantages

- Compact size  
Small space requirements
- Low weight  
Low loads
- Holder for XL guns  
No special gun holders necessary
- Integrated distance measuring system  
Precise control of angle of rotation

### Controller

- ProfiTech S

### Ordering information

- Rotary axes are planned individually in accordance with customer requirements
- The WAGNER project division will make an individual offer in request

Product variants	Item no.	Price	PH 2
Rotary axis	225259		- -



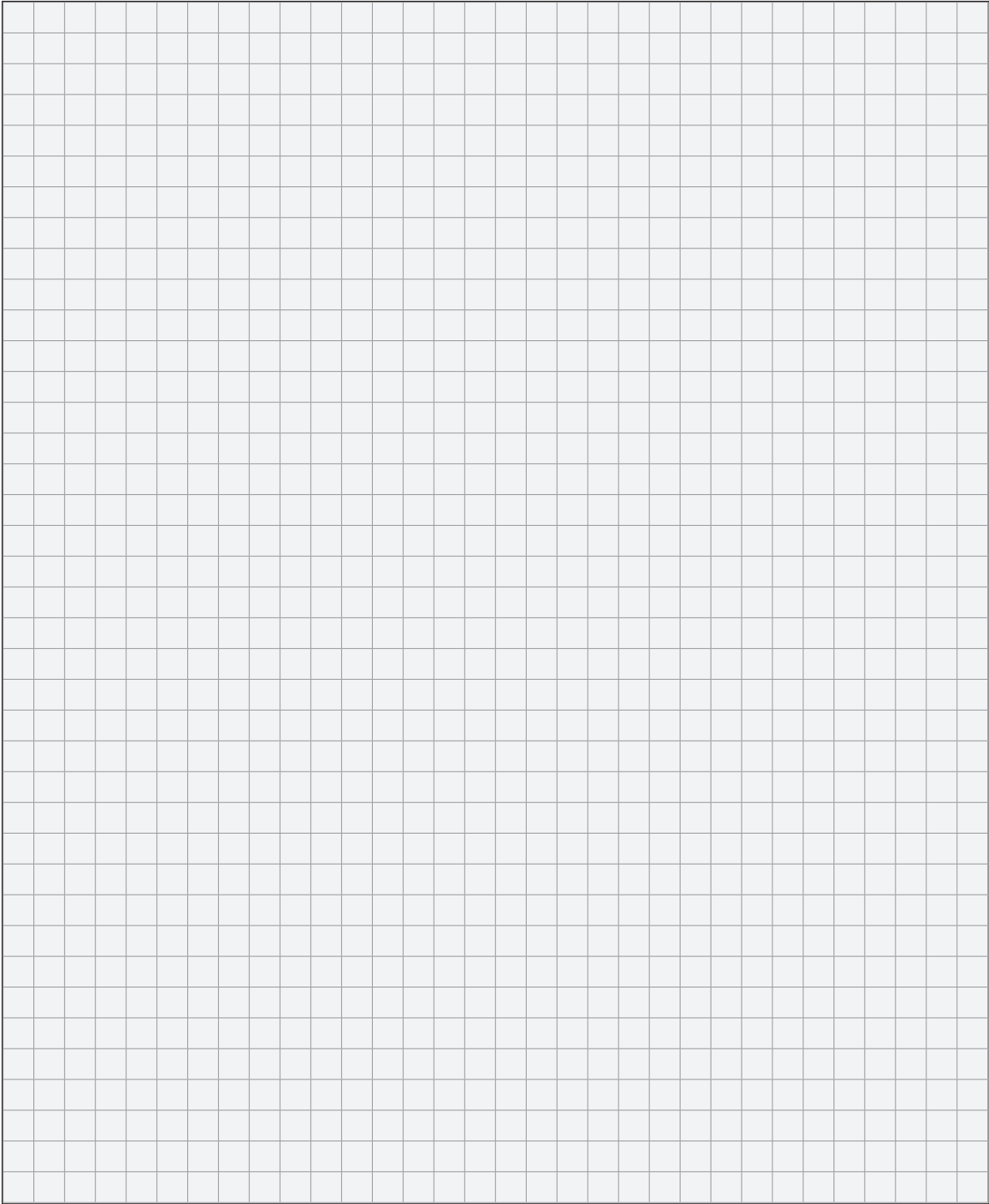

## Hose guide, type Easy V1

The Easy hose guide is a simple system that prevents bending powder and air hoses. In this way, it helps ensure trouble-free operation of the system. Type H for horizontal, type V for vertical gun arrangements.



### Special advantages

- Hoses remain freely movable  
No risk of kinking
- Secure fixation  
Very short hose lengths
- Simple, robust design  
Low-priced, long-lasting

### Included items

- As per configuration table

### Ordering information

- Please order the individual parts as specified in the configuration table.

## EASY V1

Configuration, hose guide Easy V1	Variable			Example
Vertical gun arrangement				
Maximum number of guns: 12	N1			6
Maximum workpiece height: 2,400 mm	H			1,800 mm
Max. number of hoses per gun: 2	N2			1
Item	No.	Number	Configuration	Result
Support H=2,300 mm	A	3304975	= 2 (H<1900)	2
Support H=2,800 mm	B	3304976	= 2 (H>1800)	
Angle support bracket	C	3304954	= N1*N2/2 (round up result)	3
Kink protector assy. L=600 mm	D	3304989	= N1+(N1*N2)	12
Kink protector holder	E	3107501	= D	12
Cylinder head screw M8x55	F	9900337	= C*2	6
Contact washer M8	G	3155404	= 2*C +2	14
Hexagon nut M8	H	9910107	= F	6
Cylinder head screw M6x16	I	9900325	= E	12
Washer A6.4	J	9920103	= E	12
Lock washer 6	K	9921502	= E	12
Hexagon nut M6	L	9910102	= E	12
Ring terminal M8/4-6 mm <sup>2</sup> , yellow	M	3054811	= 4	4
Plastic insulated wire 6.0 mm <sup>2</sup> , green/yellow	N	3052344	= 4	4
Ground label, self-adhesive, round	O	3050348	= 4	4
Lock washer B8	P	3050187	= 4	4
Screw anchor	Q	3145555	= 4	4
Building plan	R	3305078	= 1	1

## Hose guide, type Easy H

The Easy hose guide is a simple system that prevents bending powder and air hoses. In this way, it helps ensure trouble-free operation of the system. Type H for horizontal, type V for vertical gun arrangements.



### Special advantages

- Hoses remain freely movable  
No risk of kinking
- Secure fixation  
Short hose lengths
- Simple, robust design  
Low-priced, long-lasting

### Included items

- As per configuration table

### Ordering information

- Please order the individual parts as specified in the configuration table.

## EASY H

Configuration, hose guide Easy H	Variable			Example
Horizontal gun arrangement				
Maximum number of guns: 12	N1			6
Maximum workpiece height: 2,400 mm	H			1,800 mm
Max. number of hoses per gun: 2	N2			1
Item	No.	Number	Configuration	Result
Support H=2,300 mm	A	3304975	= 2 (H<2200)	2
Support H=2,800 mm	B	3304976	= 2 (H<2200)	
Support tube	C	3304990	= 1 (D<19) otherwise 2	1
Kink protector assy. L=600 mm	D	3304989	= N1 + (N1*N2)	12
Kink protector holder	E	3107501	= D	12
Cylinder head screw M8x100	F	9900337	= C*2	2
Contact washer M8	G	3155404	= 2*C + 2	6
Hexagon nut M8	H	9910107	= F	2
Cylinder head screw M6x55	I	9906036	= E	12
Washer A6.4	J	9920103	= E	12
Lock washer 6	K	9921502	= E	12
Hexagon nut M6	L	9910102	= E	12
Ring terminal M8/4-6 mm <sup>2</sup> , yellow	M	3054811	= 4	4
Plastic insulated wire 6.0 mm <sup>2</sup> , green/yellow	N	3052344	= 4	4
Ground label, self-adhesive, round	O	3050348	= 4	4
Lock washer B8	P	3050187	= 4	4
Sealing plug	Q	0701316	= 2*C	2
Screw anchor	R	3145555	= 4	4
Building plan	S	3305079	= 1	1

## Motion accessories

WAGNER offers a comprehensive motion technology accessories range. Please select the components you require from the table.

● Are compatible to each other

Vertical movement system	Horizontal movement system	Roller set RS 8
--------------------------	----------------------------	-----------------

Fixture					
base fixture	●			2334258	-
Counterweight 1.1kg	●			2336261	-
Base support VU 1 cpl.	●			2336702	-
gun assembly VU 1 - 1R.hor. 4 gun	●			2336731	-
gun assembly VU 1 - 1R.hor. 6 gun	●			2336732	-
gun assembly VU 1 - 2R-hor.	●			2336733	-
Gun assembly VU 1 - 2R-ver. 6 gun	●			2336734	-
Gun mount assy., square	●			3305515	-
Chain Set HU1 600-900		●		2328542	-
Chain Set HU1 901-1200		●		2328543	-
Chain Set HU1 1201-1500		●		2328544	-
Chain Set HU1 1501-1800		●		2328545	-
Energy chain set RS8 600-1200			●	2336432	-
Assembly					
PROTECTIVE CAP, BLACK	●			9990548	-
Square tube	●			8034003	-
Square tube	●			8073997	-
Accessories					
Cross clamping, sq.-rd.	●			373235	-
Cross clamp	●			373236	-
Protective cap, black	●			9998577	-

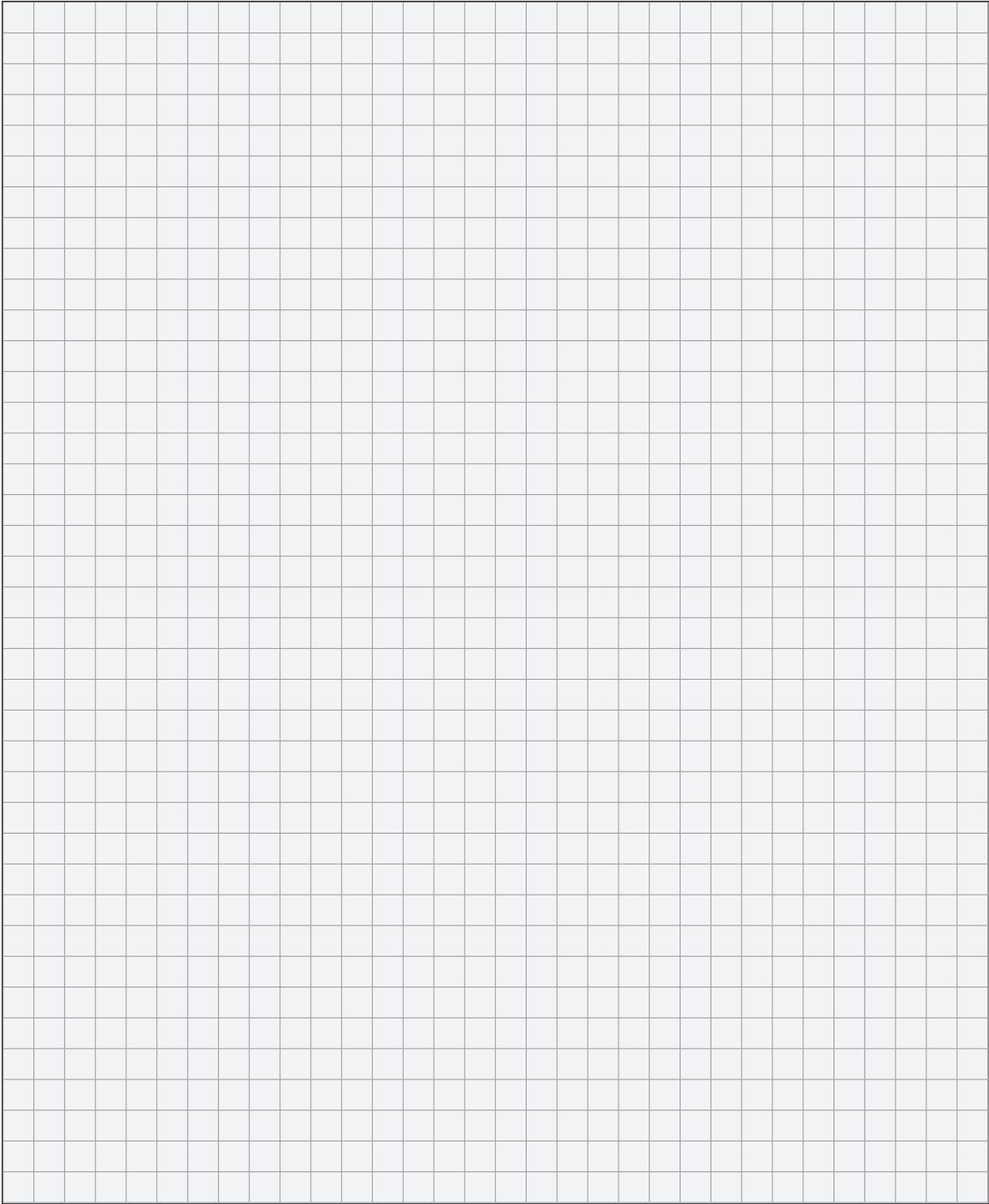

## Individual and modular for complex tasks.



Excellent reliability and high precision for optimal coating results – that's what WAGNER control technology stands for. It is the ideal basis for advanced and powerful automation solutions in powder coating. Regardless of what your application may be, we have the right solution for you.





# Control



PrimaTech controllers

106



ProfiTech M controllers

116

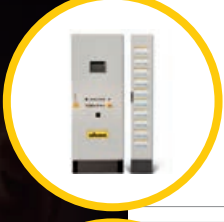

ProfiTech S controllers

122



Accessories

124

## PrimaTech control system

The PrimaTech controller range is a completely modular system with a diverse functional scope. Combining various control units and peripheral system components allows for the creation of a complete powder coating system. The system is designed with plug-in ready connections and thus ensures a safe and easy assembly. The configuration options extend from simple gun control to controlling reciprocators and sliding tables. This allows for the construction of a semi-professional all-in-one system with a functional scope for many diverse applications and offering a great price/performance ratio.

### 1. Plug and Play

Easy configuration and assembly

### 2. High Flexibility

PrimaTech can be used for controlling Corona as well as Tribo guns.

### 3. Cost-effectiveness

Additional modules (for example gap and height control) optimize the gun control. This in turn reduces the powder consumption.

### 4. Readily Extendable

The modular design allows for gradual upgrading. The control system expands depending on the requirements.

### 5. High Coating Rate

Up to 16 guns may be operated.

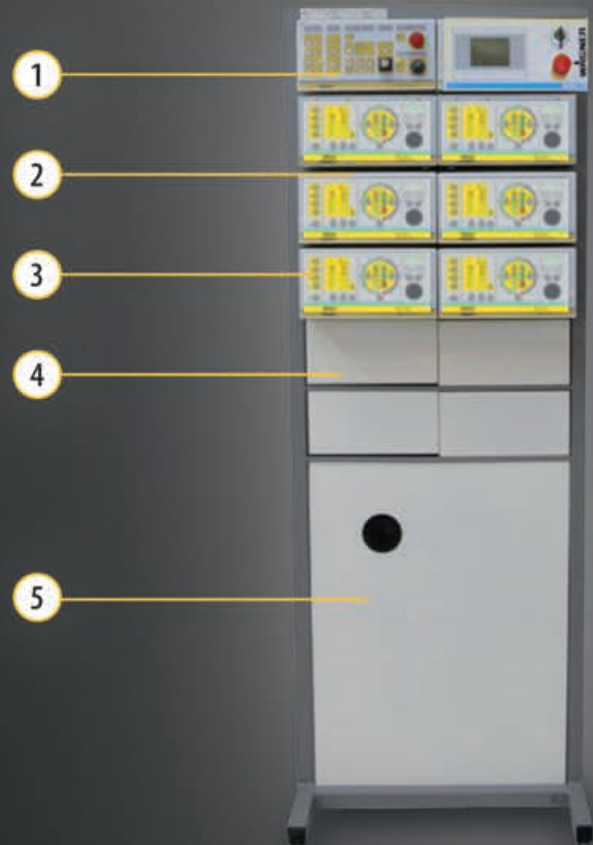

## PrimaTech-CCM

PrimaTech-CCM is a compact application control for installing an automatic system. The set includes a central control module, complemented by gun modules and a motion technology control. Application range up to 16 guns.



### Technical data

Input frequency	50 – 60 Hz
Protection class	IP 54

### Special advantages

- Modular structure, plug and play  
Simple configuration and installation, no special installation knowledge required
- Can be used with Corona and Tribo guns  
One system for 2 applications
- Control intelligence including gap control  
Reduces powder consumption
- Modules for motion equipment  
Can be used with full range of application technology

### Included items

- Maximum equipment per rack: 6 levels with 12 module spaces
- Configuration example:
  - 1 rack
  - 1 CCM-Prima central control module
  - 1 MCS-1 movement control module
  - 1 GCM-Prima gap control module
  - 8 EPG-Sprint gun control modules
  - 1 dummy plate

### Ordering information

- PrimaTech-CCM control systems can be ordered on the basis of the configuration diagrams and tables.
- Automatic configurators are also available. Ask your sales partner for more information.

## PrimaTech rack

The PrimaTech rack is a base frame with 6 shelves for 2 single modules or 1 double module. It can hold up to 10 EPG Prima control units and 1 CCM-Prima module. If additional control units are used, the available space is divided accordingly.



### Included items

- Air distributor block, item no. 0263325
- Twelve straight threaded fittings, item no. 9992106
- Twelve blind plugs, item no. 9998201
- Ground cable assy., item no. 0264332

Product variants	Item no.	Price	PH 2
Primatech rack	360091		- -

## Control unit CCM Prima

The CCM Prima control unit is the central control and operating unit for the modular PrimaTech-CCM control unit. Eight gun control units can be connected.



### Special advantages

- Central supply for the individual modules  
Easy connection
- Interlock with conveyor system  
No faulty coating
- Emergency stop switch  
Safety in the event of a malfunction

Product variants	Item no.	Price	PH 2
Control unit CCM Prima	263070		- -

## Extension control unit SCM Prima

The SCM Prima is an extension module for the PrimaTech-CCM control unit for an additional 8 gun control units.



### Special advantages

- Connection of 8 additional guns  
Easy expansion

Product variants	Item no.	Price	PH 2
Control unit SCM Prima	263071		-

## Control unit EPG Sprint

The EPG Sprint X control unit is used for all WAGNER manual and automatic guns. The precise and self-regulating AFC technology with an intuitive user interface ensures optimum gun control and thus reproducible coating results.



### Special advantages

- Optimal arrangement of the operating elements  
Self-explanatory and intuitive operation, short training periods
- Optimal arrangement of the operating elements  
Storage and retrieval of programs with all coating parameters
- Optimal arrangement of the operating elements  
Exact and reproducible settings and their precise output

### Included items

- Control unit EPG Sprint X
- Additional safeguard
- Mounting material
- CE Declaration
- NO power cable (country specific - separate)

Product variants	Item no.	Price	PH 2
Controler EPG Sprint X	2324731		-

## Motion Control Standalone MCS 1

The MCS can control up to 2 reciprocators VU 1 and 2 sliding tables HU 1. It is used as a standalone device and integrated in the PrimaTech CCM.



### Special advantages

- Universal use as standalone device or in combination with the PrimaTech CCM application control.  
Flexible application
- Controlling of max. 2 reciprocators VU 1 and 2 sliding tables VU 1  
Wide range of applications
- 50 movement profiles can be saved as recipes  
Coating parameters are quickly available.

### Included items

- Control unit in EPG housing with rear mounting. Control unit in EPG housing with rear mounting options.
- 10 m current and CAN bus cables (each) for the first motion component
- 2. Key for key switch
- 1 Touch pen for easy operation of the touchscreen
- Plug for connecting the onsite power supply.
- Attention: connection onsite power supply 230 VAC, 50/60 Hz, protection 20 A

Product variants	Item no.	Price	PH 2
Motion control standalone MCS 1	2327643		- -



## GCM Prima gap control module

Gap control module GCM Prima switches the powder feed off during gaps between workpieces.



### Technical data

Input voltage	18 – 36 V
Input power	5 W
Input frequency	50 Hz
Protection class	IP 64
Max. number of guns	8
Weight	3,3 kg, 7.3 lb

### Special advantages

- Less overspray  
Economy in the powder cycle
- Guns are only switched on when workpieces pass in front of them  
Lower wear part costs
- Smaller powder quantities in cycle  
Consistent powder quality
- Synchronization with conveyor speed  
No changing of switch-on and switch-off times as with simple time controllers

Product variants	Item no.	Price	PH 2
Control Unit GCM Prima	263114		- -

## Infeed distributor CPD 1

The CPD module enables the distribution of the supply voltage for the MCS 1, CCM-Prima und SCM-Prima modules.



### Special advantages

- Central infeed distribution in combination with motion technology  
The customer only needs to provide a power supply line.

### Included items

- Control unit for wall mounting

Product variants	Item no.	Price	PH 2
Power distribution modul CPD 1	2336208		- -

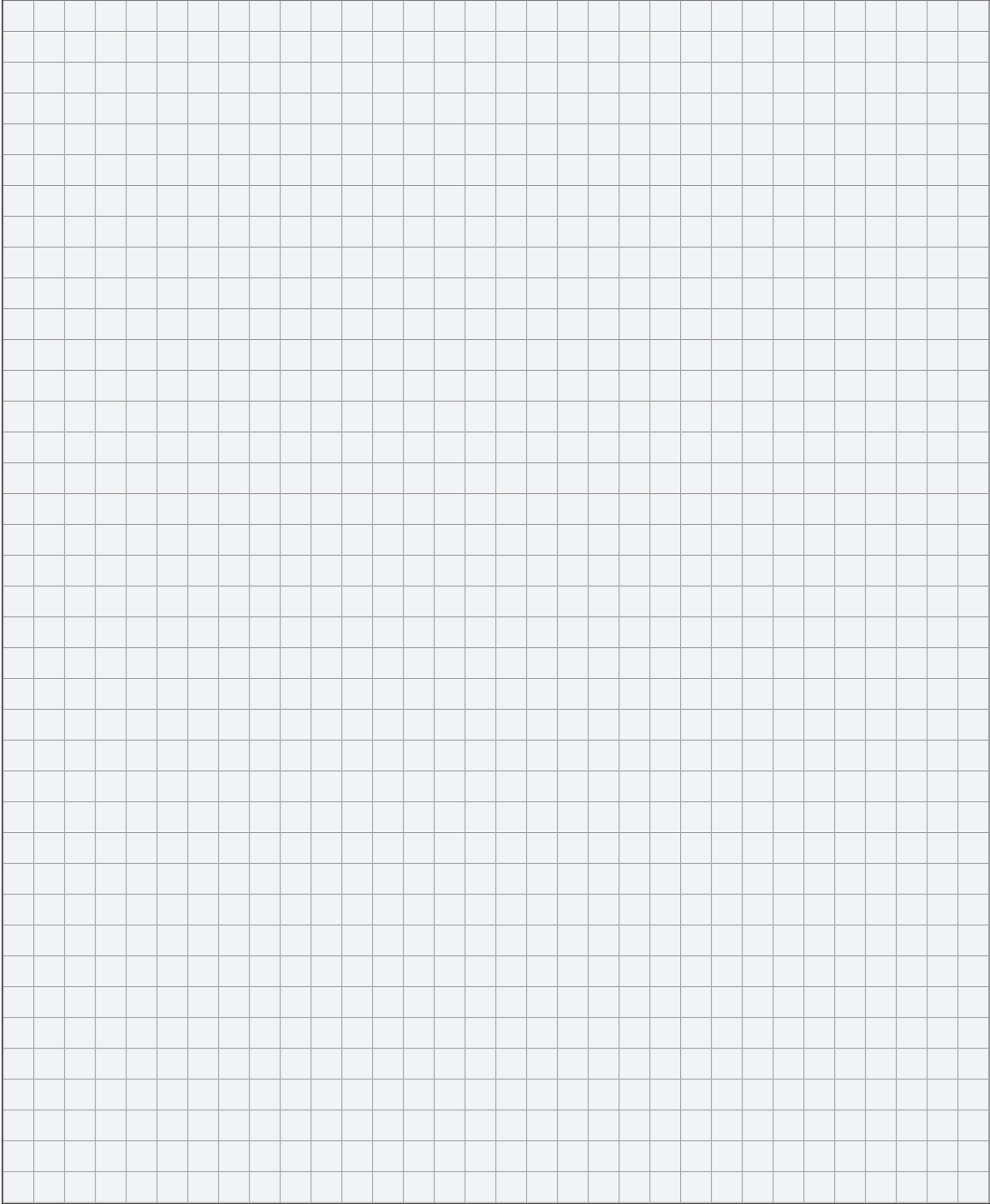

## ProfiTech M

The ProfiTech M control system is a standardized industrial control system with a comprehensive range of standard functions. Numerous interfaces ensure the integration of the system into the complete production process. Secure communication complies with industrial standards. The functional scope ranges from simple gun control to complex motion technologies to achieve coating results of the highest quality with efficient use of resources. Various controlling and monitoring functions allow for safe and reproducible coating operations.

### 1. Highly Efficient Coating

Whether simple gun control or complex motion technology with specific single functions for efficient coating processes - with ProfiTech M you achieve an efficient, safe, and reproducible coating operation.

### 2. Complete Control

The control unit EPG S2 allows the independent remote controlling of up to two guns per device using a complete CAN bus central control unit. The Closed Loop Airflow Technology ensures constant set values.

### 3. User Friendliness

The modern operating concept „Touch and Twist“ with touchscreen and turn-and-push knob ensures a central and flexible system control.

### 4. Customer Specific Flexibility

The comprehensive functional scope and the modular design with easy assembly and setup fulfill all your requirements.



## ProfiTech M

Thanks to its modular design and comprehensive functional range, the system delivers excellent coating results. The logical menu structure and the „Touch and Twist“ operating concept ensure efficient operation.



### Special advantages

- Modular system  
Simple installation and quick expansion options
- Centralized system operation  
Comfortable and efficient operation
- Graphic interface optimized for operation  
Simple and safe operation
- 1000 coating recipes with comprehensible logic  
Quick operation with repeatable results

### Included items

- Depending on the system configuration, components are required in different quantities.
- Example of a typical configuration:
  - 1 MCM master control module with touch-screen for central system control
  - 1 CPS control cabinet for power distribution and signal interlock
  - EPG S2 for controlling the guns, installed in the rack
  - Movement technology with reciprocators and transfer carriage
  - Workpiece recognition via light strips
  - Connection cables and hoses
  - Powder cabins with powder recovery unit, booth control cabinet and powder supply system are added

### Ordering information

- Special configurators are available for the system configuration.

## Master Control Module MCM

The MCM is the central control and operation unit of the ProfiTech M for operating all functions of the peripheral system components. The modern „Touch and Twist“ operating concept ensures flexible operation.



### Special advantages

- Large 10.4" color touch screen with 4:3 ratio  
Centralized system operation with touch and twist concept
- Clear and concise menu structure  
Easy and efficient operation
- Special operator guidance for complex sequences.  
Safe operation of the system in the right sequence, for example for paint changes

### Included items

- MCM control unit in housing
- 2 keys for the key switch
- Application software, maximum function

Product variants	Item no.	Price	PH 2
MCM Master Control	2330000		-

## Control cabinet CPS

The CPS control cabinet ensures the power supply for various system components. Additionally, it serves as a signal interface to the MCM module and the peripheral components.



### Special advantages

- Central power supply for the connected components.  
Only one connection point
- Main components connect using plug and socket.  
Easy and reliable connection
- Compact design  
Space saving, does not require any specific installation site.

### Included items

- CPS control, wall cabinet housing

Product variants	Item no.	Price	PH 2
MCM CPS I/O Control	2330001		- -

## Gun control module EPG S2

The EPG S2 control unit is used for all WAGNER guns in an automated system. 2 guns may be connected and independently remote-controlled using the central control unit.



### Special advantages

- Fully electronic control unit for reproducible product quantity settings  
Storage and retrieval of programs with all coating parameters
- Closed loop AFC air flow controller  
Exact and reproducible settings and their precise output
- Controlling 2 guns  
Space-saving construction

### Included items

- EPG S2 control unit for rack installation
- Power cable not included

Product variants	Item no.	Price	PH 2
Controler EPG S2	2316991		-



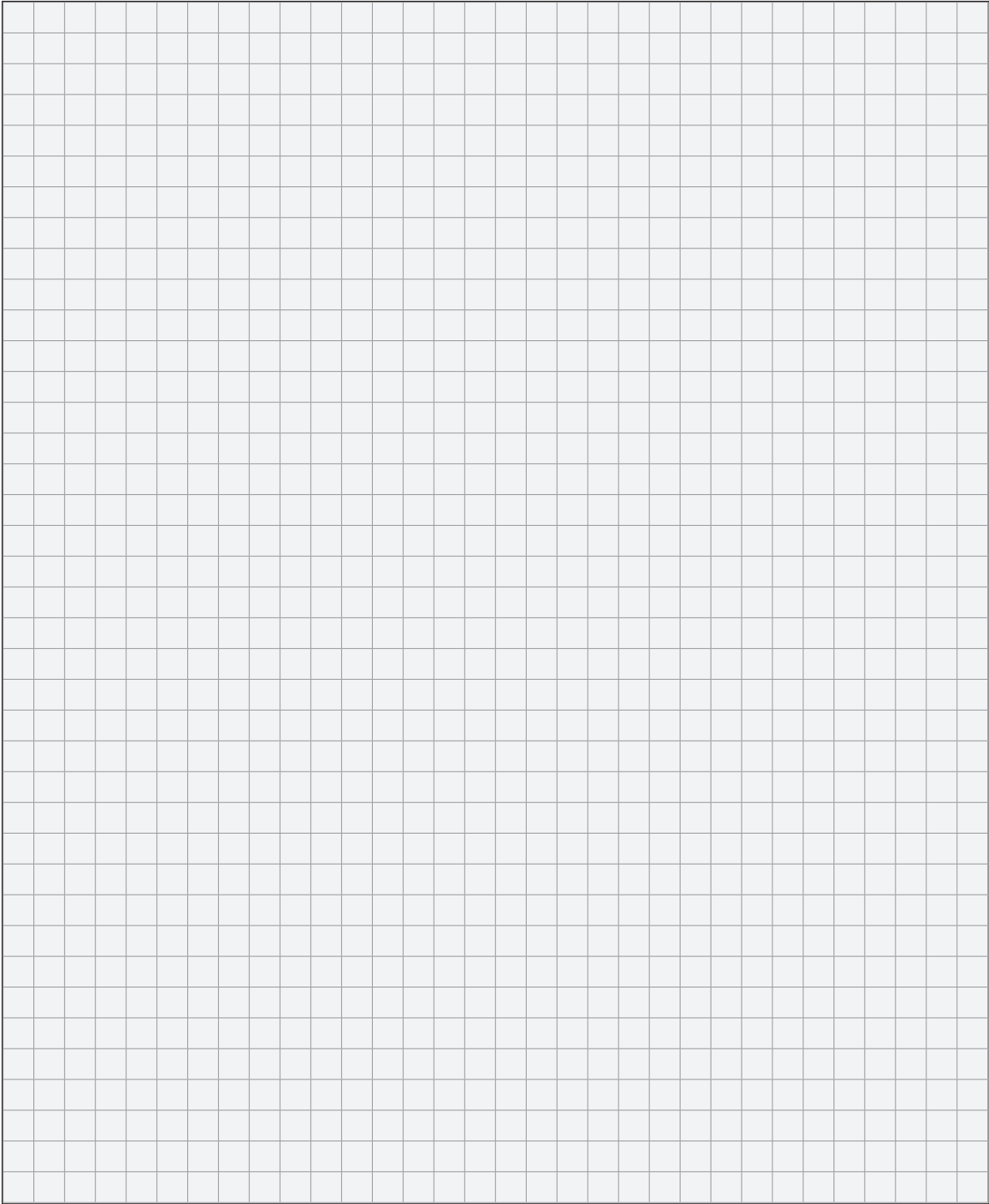

## ProfiTech S

The ProfiTech S control system is a customer specific designed system with standard function and individual special functions. The universal interfaces ensure the integration of the systems into the complete production process. Secure communication complies with industrial standards. The individual planning and design of these control systems ensure a degree of specific process reliability and high-level functionality.

### 1. Reliability

Integration of industrial control for PC or PLC based hardware. Touchscreen 9", 16:9 format - optional also with 12" and 15" (16:9).

### 2. Specific Interfaces

In addition to standard interfaces to other components, further specific data communication interfaces can be made available.

### 3. Cost-effectiveness and Performance

The partially modular design allows for cost-efficient and space-saving solutions. Precise control systems and specifically tailored software solutions that set an industry benchmark are used to achieve optimum coating performance and quality.

### 4. Flexibility and Automation

In addition to the comprehensive standard functional scope, customer specific requirements can be implemented.

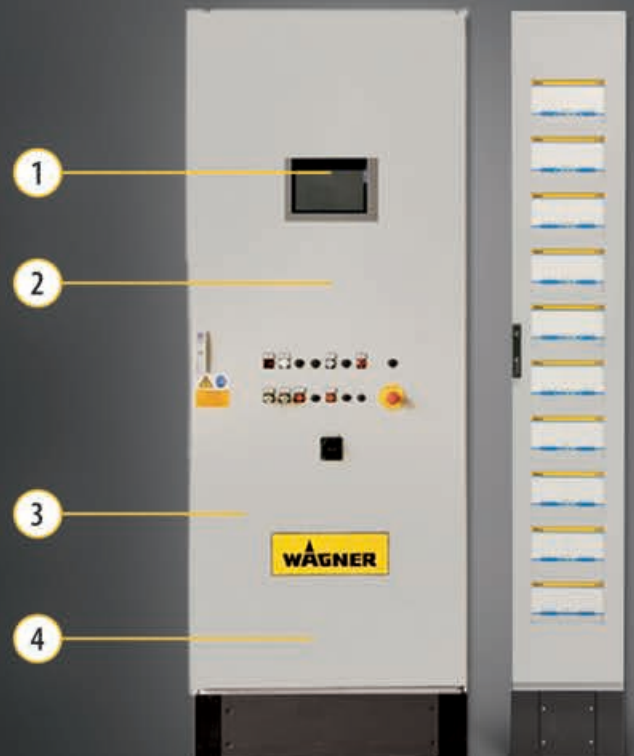

## ProfiTech S

This control system is used to control customer-specific designed powder coating systems. It allows for the implementation of simple and complex control tasks to achieve maximum coating performance.



### Technical data

Input frequency	50 Hz
Protection class	IP 54

### Special advantages

- The controller consists of individual basic modules configured to meet specific customer requirements  
Fulfills all customer requirements at a good price/performance ratio
- Industrial control with PC or PLC operating systems  
Powerful, globally available system
- System operation via touchscreen  
Central, simple, intuitive control of all system components
- Links all control procedure equipment for powder coating with recipes, synchronized gap/height/depth control, 4D robotics and work piece sensors  
Maximum coating quality, efficiency, and automation

### Ordering information

- ProfiTech S control systems are planned separately.
- The WAGNER project department will quickly draft an offer upon request.

## Accessories - Controlling

WAGNER offers a comprehensive accessories range for control systems. Please select the components you require from this table.

● Are compatible to each other

PrimaTech-CCM	PrimaTech rack	Control units	GCM Prima gap control module	Master Control Module MCM	Control cabinet CPS	Gun control module EPG S2	ProfTech M	ProfTech S
---------------	----------------	---------------	------------------------------	---------------------------	---------------------	---------------------------	------------	------------

Connector, coupling											
Hose clip					●	●		●	●	9990224	-
Air hose											
Air-hose-5,5/8mm-PU-black			●					●	●	9982078	-
Tube black, D6			●					●	●	9982079	-
Hose PU 8/5,5 rot			●					●	●	9982063	-
Hose blue D 8x1.25			●					●	●	9982062	-
Hose PE-PU 8/5,5 green			●							9982077	-
Hose rubber 3725 yellow 20bar								●	●	3310114	-
Fixture											
Mounting, rot. transducer			●							3104680	-
Front + doors, lamp			●							3152288	-
Assembly profile scan/2025 with fixings			●							3151289	-
Assembly profile scan/2400 with fixings			●							3151033	-
Tube round				●				●		3070646	-
Base clamp				●				●		3106681	-
Leg clamp piece				●				●		701305	-
Stand					●			●		3066838	-
BT-2R1 - Holder set for CML720								●	●	2345087	-
BT-2L - Holder set for CML720								●	●	2345085	-
BT-2Z - Holder set for CML720								●	●	2345084	-
Assembly											
Profile rail, C			●							3054988	-
Tenon Block 8 St M5			●							3136285	-
Power cable											
Connector-Set ECO	●									263092	-
Expansion kit	●									263093	-
Extension set	●									263094	-
Mains cable + Stak 200 CH	●									241271	-
Mains cable Japan	●									264625	-
Cable GCM-CCM			●							263241	-
Cable GCM 2007-1 GCM 2007-2			●							263253	-
Extension cable			●							263252	-
Transition cable			●							360246	-
connection cable T0.5 L=0.5m			●							3148831	-
connection cable T2 L=2.0m			●							3148832	-
connection cable T5 L=5.0m			●							3148833	-
connection cable T10 L=10.0m			●							3148834	-
Grounding-Kit			●							360262	-
Oil flex 5x6mm <sup>2</sup>				●	●					3125457	-

PrimaTech-CCM
PrimaTech rack
Control units
GCM Prima gap control module
Master Control Module MCM
Control cabinet CPS
Gun control module EPG S2
ProfTech M
ProfTech S

#### Power cable

Encoder Connecting Cable M12 M/F 30Meter											2336565	-
Main connection primatech											360263	-

#### Sensor

Incremental Encoder assy	●											3110923	-
Light barrier with plug	●											3113707	-
Light curtain SCAN S30-450	●											3148826	-
Light curtain SCAN S30-1200	●											3148827	-
Light curtain SCAN S30-1650	●											3148828	-
Light curtain Scan S30-2025	●											3148829	-
Light curtain SCAN S30-2400	●											3148830	-
Incremental encoder 100 pulse	●											9955239	-
Light curtain K40-1600										●	●	3127024	-
light curtain K40-480 transmitter & rece										●	●	3127327	-
light curtain K40-1920 transmitter & rece										●	●	3127328	-
light curtain K40-320 transmitter & rece										●	●	3127544	-
light curtain K40-640 transmitter & rece										●	●	3127549	-
light curtain K40-960 transmitter & rece										●	●	3127552	-
light curtain K40-1280 transmitter & rec										●	●	3127555	-
light curtain K40-2560 transmitter & rec										●	●	3127564	-
light curtain K40-2880 transmitter & rec										●	●	3127567	-
light curtain K40-3200 transmitter & rec										●	●	3127598	-
light curtain K40-2240 transmitter & rec										●	●	3127689	-
Light curtain K20-320										●	●	3158584	-
Light curtain K20-480										●	●	3158585	-
Light curtain K20-640										●	●	3158586	-
Light curtain K20-960										●	●	3158587	-
Light curtain K20-1280										●	●	3158588	-
Light curtain K20-1600										●	●	3158589	-
Light curtain K20-1920										●	●	3158590	-
Light curtain K20-2240										●	●	3158591	-
Light curtain K20-2560										●	●	3158592	-
Light curtain K28820										●	●	3158593	-
Light curtain K20-3200										●	●	3158594	-
Light curtain CML720 unit 160/05 CANopen										●	●	2345151	-
Light curtain CML720 unit 310/20 CAN										●	●	2345152	-
Light curtain CML720 unit 470/20 CAN										●	●	2345153	-
Light curtain CML720 unit 630/20 CAN										●	●	2345154	-
Light curtain CML720 unit 950/20 CAN										●	●	2345155	-
Light curtain CML720 unit 1270/20 CAN										●	●	2345156	-
Light curtain CML720 unit 1590/20 CAN										●	●	2345157	-
Light curtain CML720 unit 1910/20 CAN										●	●	2345158	-

## Accessories - Controlling

PrimaTech-CCM	PrimaTech rack	Control units	GCM Prima gap control module	Master Control Module MCM	Control cabinet CPS	Gun control module EPG S2	ProfiTech M	ProfiTech S
---------------	----------------	---------------	------------------------------	---------------------------	---------------------	---------------------------	-------------	-------------

Sonsor											
Light curtain CML720 unit 2230/20 CAN								●	●	2345159	-
Light curtain CML720 unit 2550/20 CAN								●	●	2345160	-
Light curtain CML720 unit 2870/20 CAN								●	●	2345161	-
Light curtain CML720 unit 610/40 CAN								●	●	2345162	-
Light curtain CML720 unit 930/40 CAN								●	●	2345163	-
Light curtain CML720 unit 1250/40 CAN								●	●	2345164	-
Light curtain CML720 unit 1570/40 CAN								●	●	2345166	-
Light curtain CML720 unit 1890/40 CAN								●	●	2345167	-
Light curtain CML720 unit 2210/40 CAN								●	●	2345169	-
Light curtain CML720 unit 2530/40 CAN								●	●	2345170	-
Light curtain CML720 unit 2850/40 CAN								●	●	2345171	-

Accessories											
Angular pipe	●							●		700120	-
Orifice metal Digitech		●								360238	-

Air distribution											
Distributorblock		●								263325	-

Plug, boxes											
Connection box, GCM2007				●						263254	-

Accessories											
MCM Cable Set 10M				●	●					2330002	-
MCM CPS I/O Control				●				●		2330001	-
mGuard rs 2000Tx/Tx VPN 550				●	●	●		●		2322358	-
Installation set MCM - mGuard				●				●		2340037	-
Support for hollow encoder cpl.					●			●		2335512	-
CAN Bus Terminator Female M12 5pol					●			●		2338042	-
Profitech M - SFM2					●			●		2342292	-
Plug for safety doors					●			●		2342305	-
CAN Buscable 5.0 Meter					●	●		●		2320129	-
CAN Buscable 10.0 Meter					●	●		●		2320130	-
Connection Set EPG S2						●				2321529	-
CAN Buscable 0.6 Meter						●		●		2320127	-
CAN Buscable 2.0 Meter						●		●		2320128	-
CAN Bus Terminator Male M12 5pol						●		●		2321402	-
Rack EPG S2 assy.						●		●	●	2328670	-
Carrier plate EPG S2						●		●	●	2328668	-
Cover plate						●		●	●	2328669	-
Controler EPG S2								●	●	2316991	-
Connection cable for CML720 R/T - 5m								●	●	2345082	-
Y- Connection cable for CML720 - CAN								●	●	2345083	-

Accessories											
manifold Exact12 4xM12								●	●	2345173	-

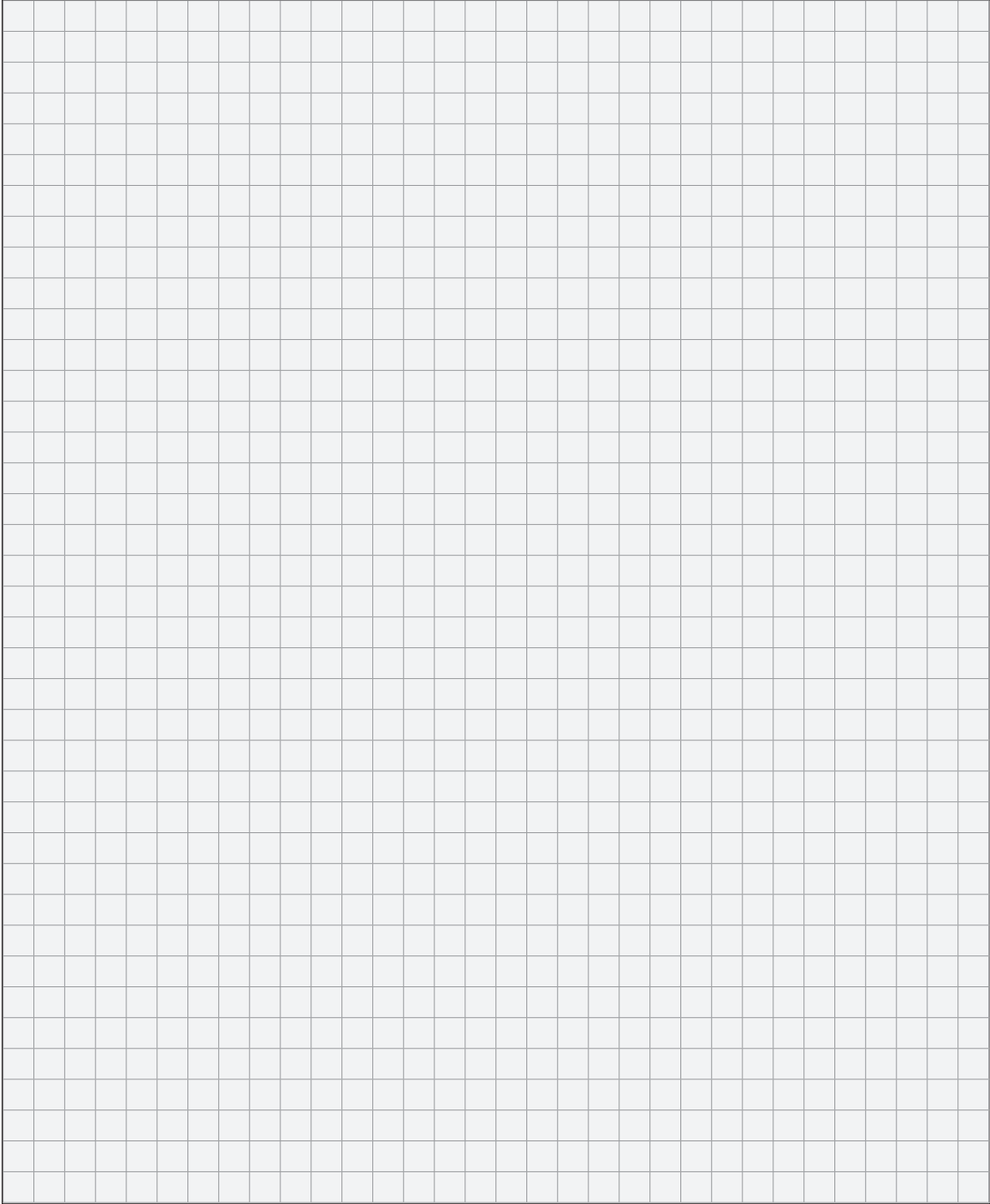

## Our best standards ensure an immediate start.

WAGNER complete systems and packages include high quality components, which are also used for complex customer specific systems. This is essential for excellent coating results. Standardization and intelligent modular concepts allow for customer specific adaptation.







## Complete system



PrimaCube complete system 130



PrimaCube booth package 136

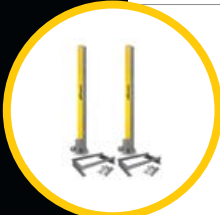

PrimaCube movement packages 138



Accessories 139

## PrimaCube complete system

The complete system includes booth, mono cyclones with final filter, pipings, powder center with central control system application technology with PrimaSprint gun control and reciprocators as well as installation material.

### 1. Complete system

The complete system includes booth, mono cyclones with final filter, pipings, powder center with central control system application technology with PrimaSprint gun control and reciprocators as well as installation material.

### 2. Variants for Individual Designs

The systems allows for individual planning regarding the number of manual coaters, number of guns and the gun arrangement.

### 3. Extensive Work Piece Range

The maximum work piece dimensions of H=2,000 mm x W= 800 mm allow for the coating of a wide range of work pieces.

### 4. Compact design

The PrimaCube systems allow for a space-saving installation, thanks to their compact design and arrangement.

### 5. High quality technology

- AFC air flow regulator with closed-loop technology
- HVM digital high-voltage module
- Optimized feeding systems (efficiency, wear)
- Optimized nozzle systems (layer thickness distribution, charging)
- Booth suction concept with 2 suction pipes for minimal impact on the powder cloud.



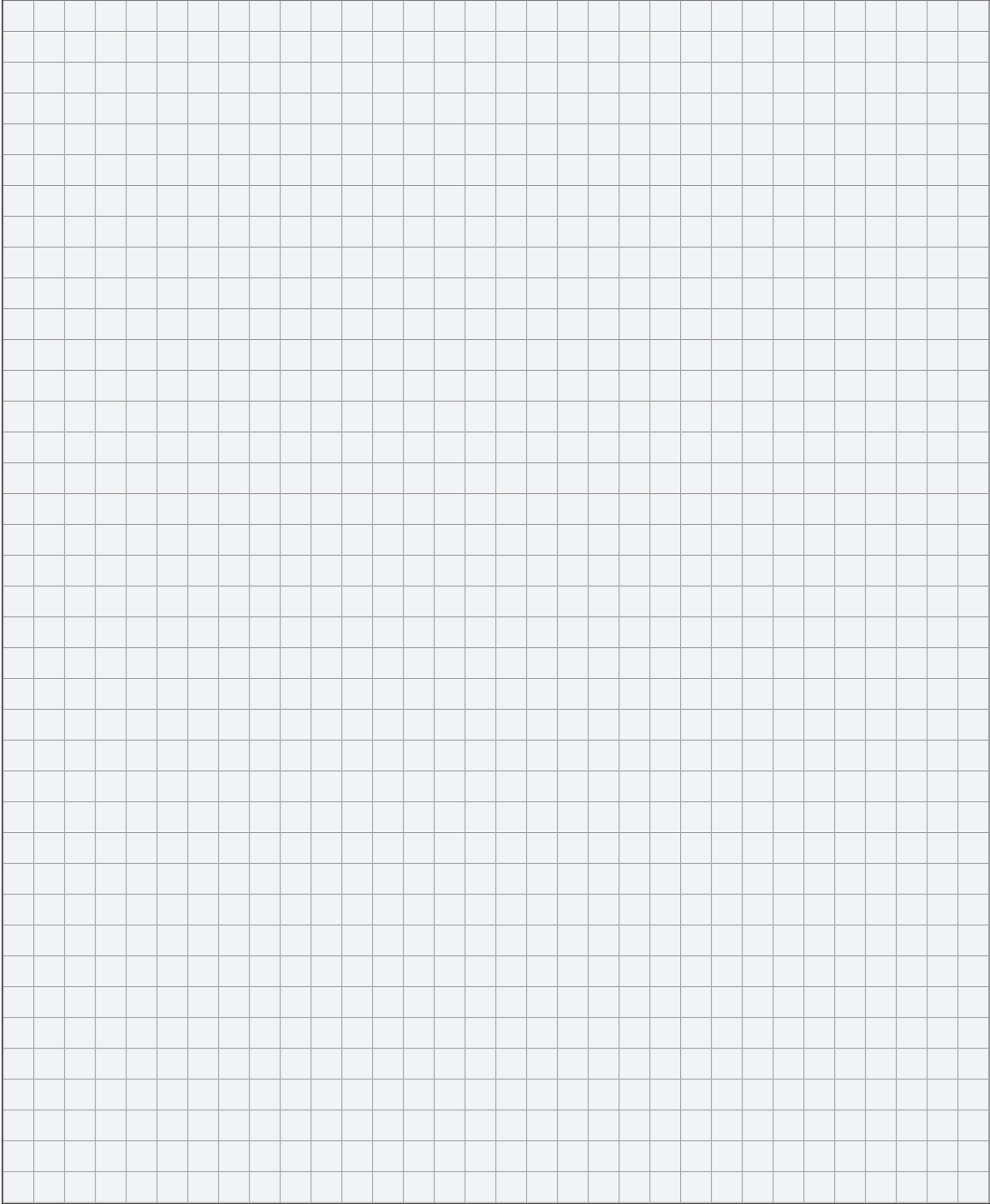

## Complete systems 12000

The complete system includes all required components for the installation of a complete system. Several versions and accessories allow for individual customization. It offers all functions required for a high coating quality and a fast paint change.



Technical data	
Fan motor power	30 W
Total power consumption	32 kW
Min. compressed air hose cross section	25,40 mm, 1 in
Air inlet pressure	0,6 – 0,8 MPa, 6,0 – 8,0 bar, 87 – 116 PSI
Three-phase current connection	220–240 / 380–420 V, 50 Hz
Suction capacity, exhaust	12.000 m <sup>3</sup> /h

### Special advantages

- Booth housing with PVC sandwich construction, 2,5 m length  
Rapid and easy paint change, partially automated (dependent on configuration)
- Suction power 12,000 m<sup>3</sup>/h  
For workpieces H1,400xW600
- Manually coated positioned on the front side  
Direct access to the workpiece ensures the highest coating quality
- Variable gun arrangement  
Customized layout possible

### Included items

- Booth housing made of PVC sandwich elements
- 3 gun slots per side
- 1 front manual coating station
- Max. work piece dimensions H=1,400 mm x W=600 mm
- Monocyclone with final filter 12.00 m<sup>3</sup>/h
- Controller for final filter
- Peristaltic pump
- PrimaCenter integral powder center with centralized system operation
- Application equipment according to the configuration selection
- Assembly material
- The arrangement of the components is based on the standard layout.
- Without motion package

### Ordering information

- The complete PrimaCube system contains all components and assembly material for installing a complete powder coating system.
- The arrangement of the components is based on the standard layout.
- The system is available in versions with various numbers of guns and gun arrangements.
- The appropriate model is selected based on the work piece dimensions, work piece geometry, and conveyor speed.
- WAGNER provides various design tools for determining the appropriate available version.

Product variants	Item no.	Price	PH 2
PrimaCube 12000, 4x PEA-C4XL w/o moving	2336116	-	-
PrimaCube 12000, 6x PEA-C4XL w/o moving	2336117	-	-
PrimaCube 12000, 8x PEA-C4XL w/o moving	2336118	-	-
PrimaCube 12000, 10x PEA-C4XL w/o moving	2336119	-	-
PrimaCube 12000, 12x PEA-C4XL w/o moving	2336120	-	-

# Complete systems 12000

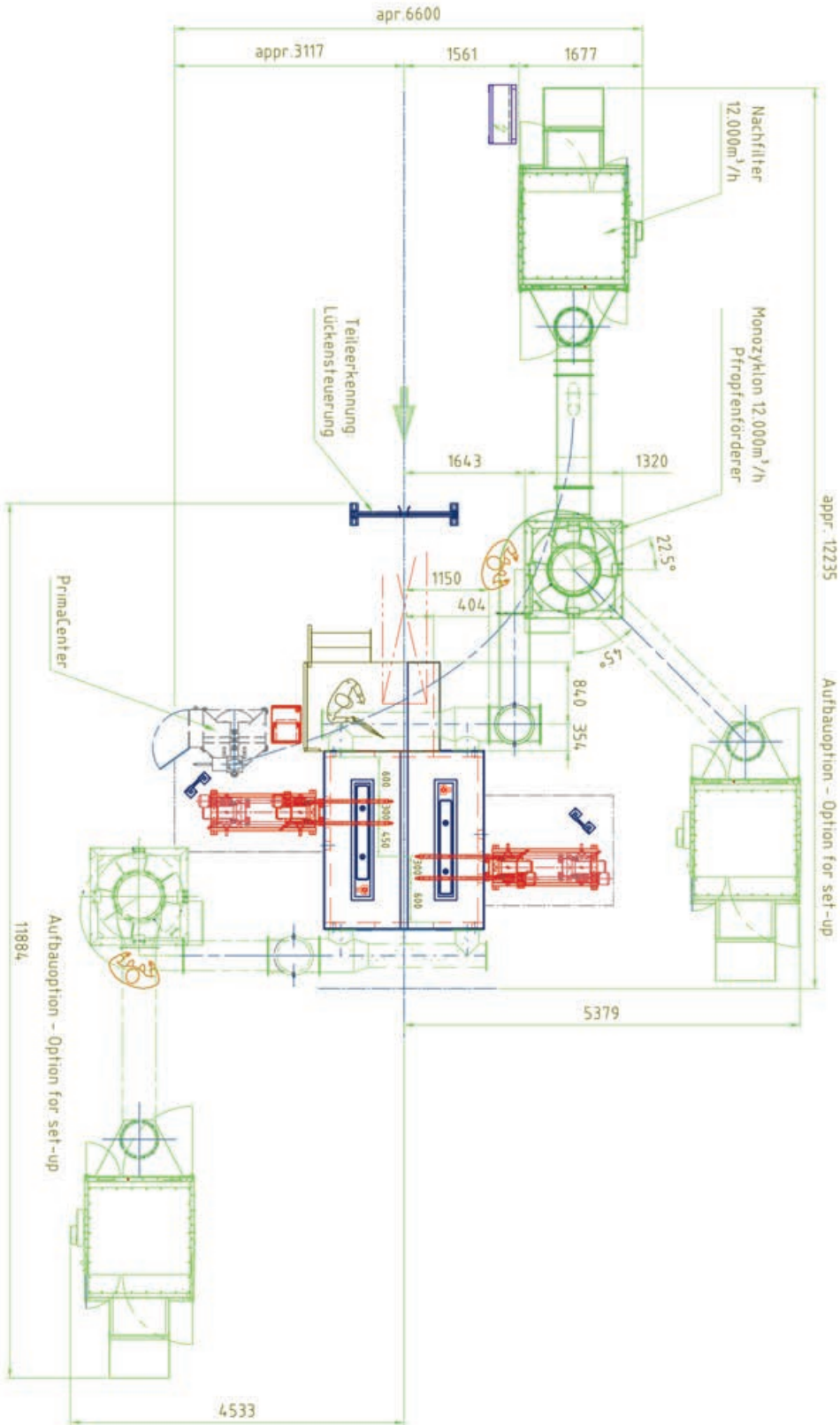

## Complete systems 16000

The complete system includes all required components for the installation of a complete system. Several versions and accessories allow for individual customization. It offers all functions required for a high coating quality and a fast paint change.



Technical data	
Fan motor power	37 W
Total power consumption	39 kW
Min. compressed air hose cross section	25,40 mm, 1 in
Air inlet pressure	0,6 – 0,8 MPa, 6,0 – 8,0 bar, 87 – 116 PSI
Three-phase current connection	220–240 / 380–420 V, 50 Hz
Suction capacity, exhaust	16.000 m <sup>3</sup> /h m <sup>3</sup> /h

### Special advantages

- Cabin housing constructed of PVC sandwiches, 2.5m long  
Rapid and easy paint change, partially automated (dependent on configuration)
- Suction power 16,000 m<sup>3</sup>/h  
For workpieces H2,000xB800
- Manually coated, positioned on the front side  
Direct access to the workpiece ensures the highest coating quality
- Variable gun arrangement  
Customized layout possible

### Included items

- Booth housing made of PVC sandwich elements
- 3 gun slots per side
- 1 front manual coating station
- Max. work piece dimensions H=2,000 mm x W=800 mm
- Monocyclone with final filter 16,000 m<sup>3</sup>/h
- Controller for final filter
- Peristaltic pump
- PrimaCenter integral powder center with centralized system operation
- Application equipment according to the configuration selection
- Assembly material
- The arrangement of the components is based on the standard layout.
- Without motion package

### Ordering information

- The complete PrimaCube system contains all components and assembly material for installing a complete powder coating system.
- The arrangement of the components is based on the standard layout.
- The system is available in versions with various numbers of guns and gun arrangements.
- The appropriate model is selected based on the work piece dimensions, work piece geometry, and conveyor speed.
- WAGNER provides various design tools for determining the appropriate available version.

Product variants	Item no.	Price	PH 2
PrimaCube 16000, 4x PEA-C4XL w/o moving	2336131		- -
PrimaCube 16000, 6x PEA-C4XL w/o moving	2336132		- -
PrimaCube 16000, 8x PEA-C4XL w/o moving	2336133		- -
PrimaCube 16000, 10x PEA-C4XL w/o moving	2336135		- -
PrimaCube 16000, 12x PEA-C4XL w/o moving	2336136		- -

# Complete systems 16000

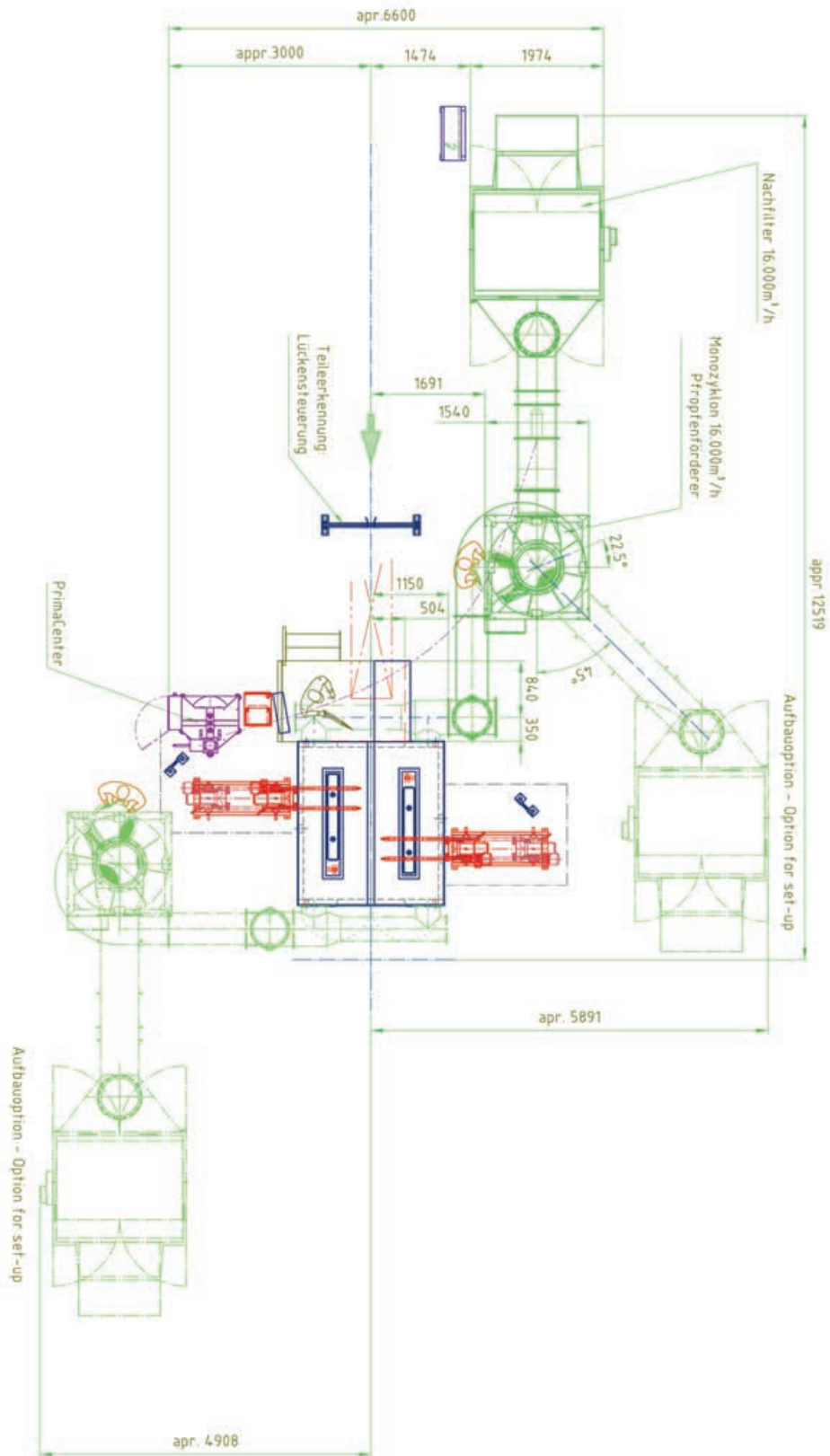

## PrimaCube booth package

The PrimaCube booth package includes the booth, mono cyclones with final filters, pipings, a peristaltic feed pump, and a booth control cabinet.

### 1. Complete Package

The PrimaCube booth package includes the booth, mono cyclones with final filters, pipings, a peristaltic feed pump, and a booth control cabinet.

### 2. Variants for Individual Designs

The booth package can be selected with one or two manual coaters.

### 3. Extensive Work Piece Range

The maximum work piece dimensions of H=2,000 mm x W= 800 mm allow for the coating of a wide range of work pieces.

### 4. Safe Functioning

Coordinated components ensure the functioning of the system.





## PrimaCube booth system

The PrimaCube booth system is a fully functional booth system with monyclone recovery unit and controller. It can be combined with any application equipment and powder centers.



Technical data	
Min. compressed air hose cross section	25,40 mm, 1 in
Air inlet pressure	0,6 – 0,8 MPa, 6,0 – 8,0 bar, 87 – 116 PSI
Three-phase current connection	220–240 / 380–440 V, 50 Hz

### Special advantages

- Booth housing with PVC sandwich construction
- Rapid and easy paint change, partially automated (dependent on configuration)
- Very low powder quantities in the cycle for consistently high quality coating results  
Direct access to workpiece ensures very high coating quality
- Walk-in booth  
Access to all locations

### Ordering information

- The booth system is delivered without application equipment.
- The arrangement of the components is based on the standard layout.

Product variants	Item no.	Price	PH 2
Booth package PrimaCube System 12000	2329936		- -
Booth package PrimaCube System 16000	2313691		- -

## PrimaCube System movement packages

PrimaCube movement packages consist of 2 reciprocators and manual or electrical sliding table with all required connecting cables, configured to match the booth package.



### Special advantages

- Complete package, including connecting cable
- Simple configuration
- Configured according to booth size
- Visual and functional integration

### Included Items

- 2 Reciprocator VU 1-1800 or VU 1-2400
- 2 Roller set RS 8-1000
- As alternativ to roller set: Elektric sliding table HU 1-1000
- Connection cable

### Ordering information

- Movement packages complete the PrimaCube system. A packet may be selected, depending on the booth size and the desired functional scope.

Product variants	Item no.	Price	PH 2
Moving Package 2x VU1-1800, 2x RS8-1000	2336138		- -
Moving Package 2x VU1-2400, 2x RS8-1000	2336140		- -
Moving Package 2x VU1-1800, 2x HU1-1000	2336143		- -
Moving Package 2x VU1-2400, 2x HU1-1000	2336144		- -

## Complete system accessories

Wagner offers a comprehensive accessories range for WAGNER complete systems. Please select the components you require from this table.

● Are compatible to each other

Complete systems 12000	Complete systems 16000	PrimaCube booth system
------------------------	------------------------	------------------------

Container					
Powder Container PrimaCenter	●	●	●	3918797	-
Air hose					
spiralhose PVC grey d150	●	●	●	2312326	-
Accessories					
PrimaSprint manual set F incl. console	●	●		2313689	-
Manual Unit Sprint Airfluid	●	●		2329483	-
Extention set gap control	●	●		2336115	-
PrimaCube-MC-Roof, additional	●	●	●	2312607	-
PrimaCube-manual coater 16.000	●	●	●	2312608	-
PrimaCube-manual coater 12000	●		●	2329939	-
BENEFICIATION d10	●		●	241580	-
FLAT SEAL	●		●	241581	-
PrimaCenter integral			●	2330014	-

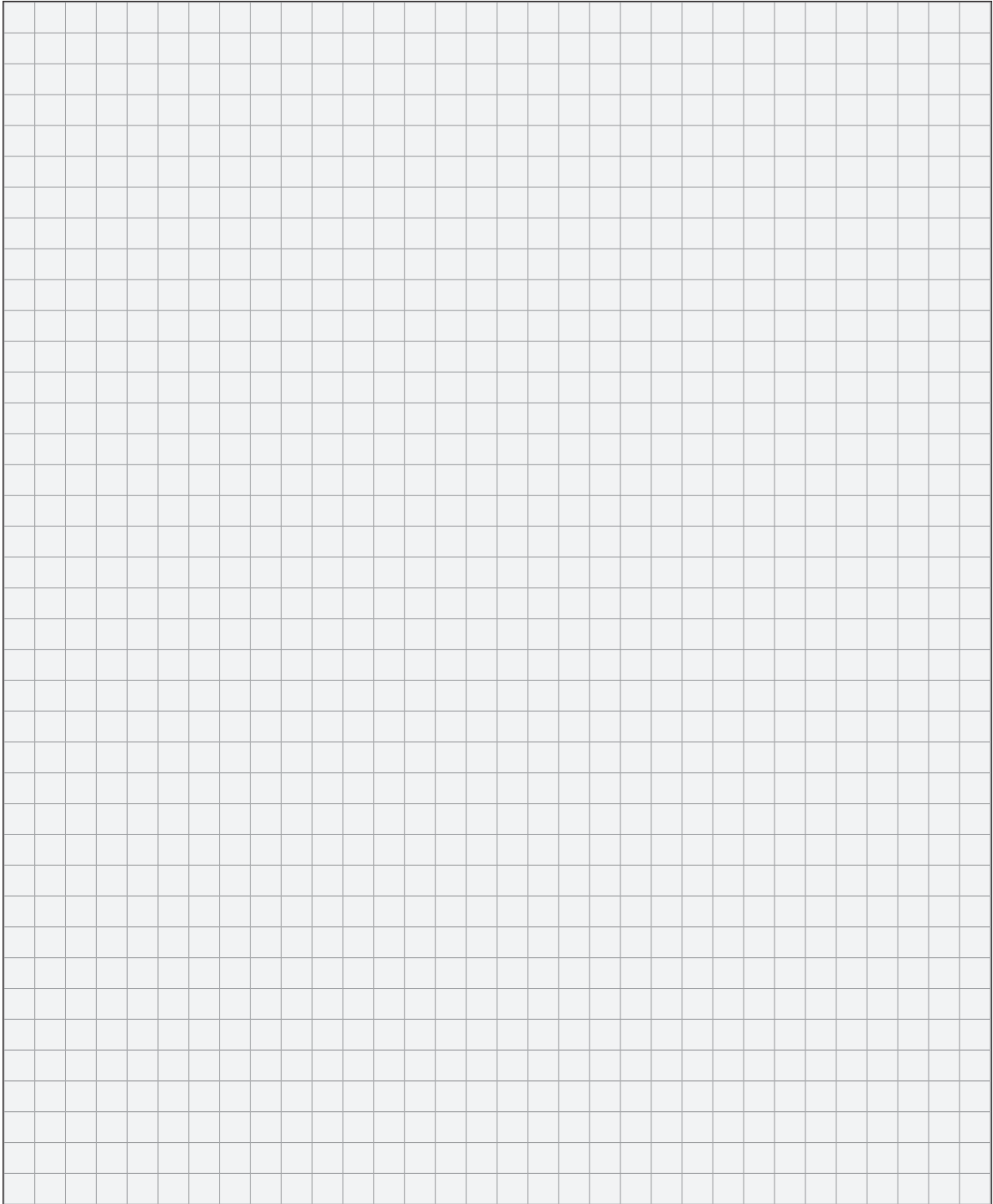

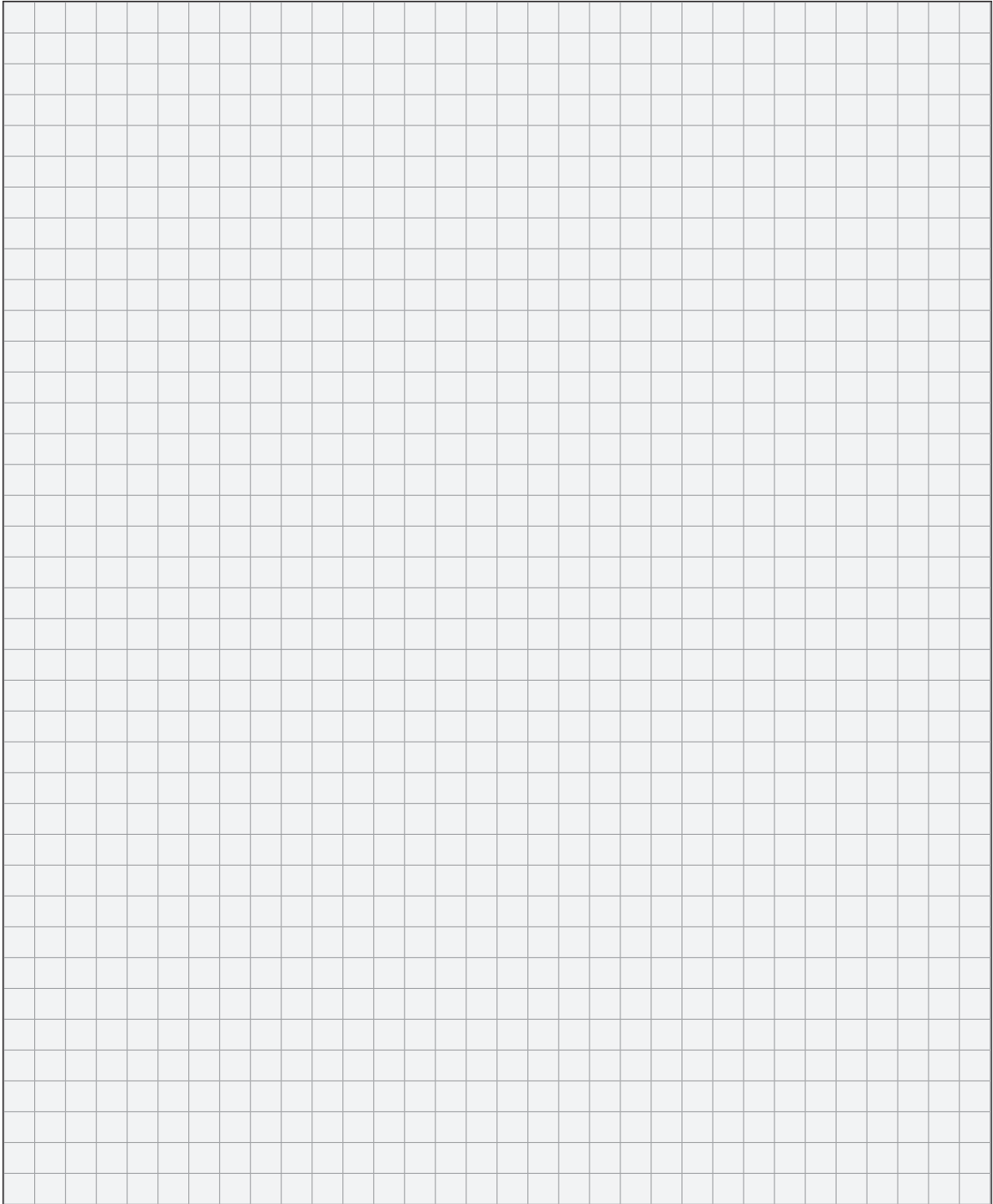

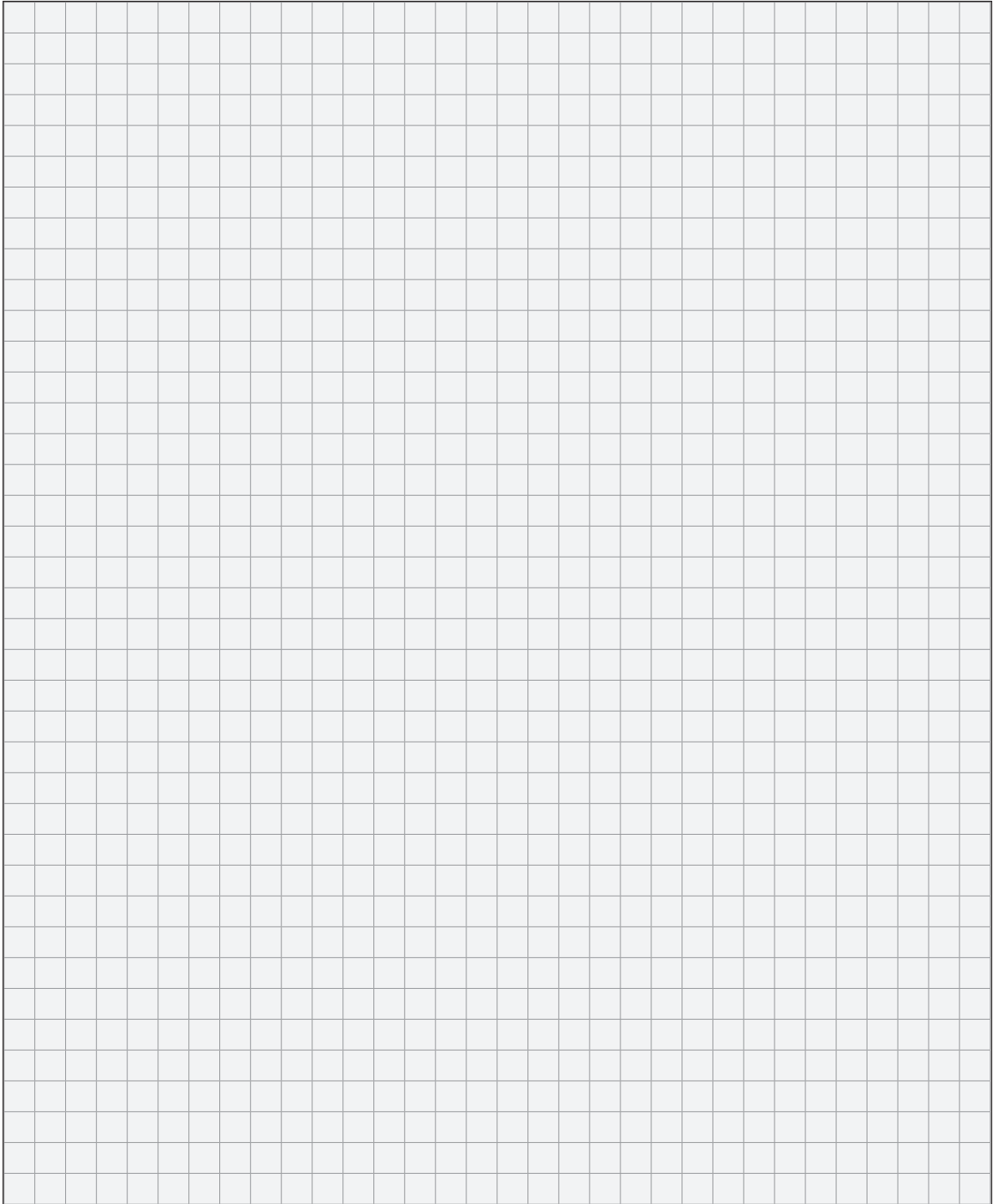



Efficiente  
Innovative  
Wagner

Система  
Affidabile

J. Wagner GmbH  
Industrial Solutions  
D-88677 Markdorf  
**Tel +49 (0) 7544 505 - 0**  
Fax +49 (0) 7544 505 - 1200

J. Wagner AG  
Industrial Solutions  
CH-9450 Altstätten/SG  
**Tel +41 (0) 71 7572211**  
Fax +41 (0) 71 7572323