



Translation of the Original Operating Manual

EPG-SPRINT X

Universal Control Unit for Powder Guns

Version 06 / 2014

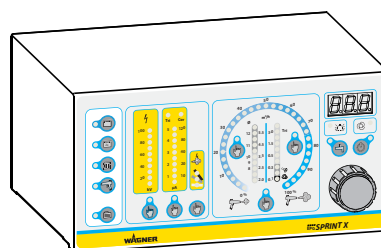

P_01742



0102



II 3(2)D IP64 80 °C

Table of Contents

1	GENERAL INFORMATION	6
1.1	Preface	6
1.2	Warnings, Notices, and Symbols in this Operating Manual	6
1.3	Languages	7
1.4	Abbreviations	7
2	CORRECT USE	8
2.1	Device Type	8
2.2	Type of Use	8
2.3	Use in Potentially Explosive Areas	8
2.4	Safety Parameters	9
2.5	Reasonably Foreseeable Misuse	9
2.6	Residual Risks	10
3	IDENTIFICATION	11
3.1	Explosion Protection Identification in Accordance with ATEX	11
3.2	Permissible Device Combinations	11
4	GENERAL SAFETY INSTRUCTIONS	12
4.1	Safety Instructions for the Operator	12
4.1.1	Electrical Devices and Equipment	12
4.1.2	Staff Qualifications	12
4.1.3	Safe Work Environment	12
4.2	Safety Instructions for Staff	13
4.2.1	Safe Handling of WAGNER Powder Spray Devices	13
4.2.2	Grounding the Device	13
4.2.3	Product Hoses	13
4.2.4	Cleaning	14
4.2.5	Handling Powder Lacquers	14
4.3	Protective and Monitoring Equipment	15
4.4	Safety Feature Identification	16
5	DESCRIPTION	17
5.1	Areas of Application	17
5.2	Technical Data	18
5.3	Permitted Accessories	20
5.4	Scope of Delivery	20
5.5	Operating Elements	21
5.5.1	Operating Elements Front Side	21
5.5.2	Connections on the Rear Side of the EPG-SPRINT X	26
6	ASSEMBLY AND COMMISSIONING	28
6.1	Training Assembly/Commissioning Staff	28
6.2	Storage Conditions	28
6.3	Installation Conditions	28
6.4	Connecting the Manual Gun	29
6.5	Connecting the Automatic Gun	30
6.6	Grounding	31
6.6.1	Grounding the Powder Coating System	32

Table of Contents

7	OPERATION	33
7.1	Training the Operating Staff	33
7.2	Safety Instructions	33
7.3	Preparations for Commissioning	35
7.3.1	Operating Modes	35
7.3.2	Gun Recognition	35
7.3.3	Manual Gun Mode with External Control	36
7.3.4	Basic and Factory Settings	36
7.4	Recipes	37
7.4.1	"Double Click" Recipe (High Dynamic Remote)	38
7.5	Air High Output Mode (High Powder Output)	39
7.5.1	Combining the Air Outputs	39
7.5.2	Activating High Output Mode (C17)	40
7.6	Changing and Saving Recipes	43
7.6.1	Recipe No. 1-4	43
7.6.2	Recipe No. 5-50	44
7.7	Setting and Changing Coating Parameters	45
7.7.1	Setting the Total Air Volume	45
7.7.2	Setting the Powder Feed Quantity	46
7.7.3	Setting the Additional Air (Atomizing/Ionizing/Tribo Air Volume)	47
7.7.4	Setting the High-voltage	48
7.7.5	Display of Actual High-voltage Value	49
7.7.6	Setting the Current Limitation	50
7.7.7	Displaying Actual Value of Current Limitation	51
7.7.8	Setting the U/I Characteristics	52
7.8	Purge Function	54
7.8.1	Hose Purge Function	54
7.8.2	Cleaning Purge Function	54
7.8.3	Procedure for Cleaning Purging with Manual Guns	55
7.8.4	Procedure for Cleaning Purging with Automatic Guns	56
7.9	Starting Output Setting (Zero Adjustment)	57
8	CLEANING AND MAINTENANCE	59
8.1	Cleaning	59
8.1.1	Cleaning Staff	59
8.1.2	Safety Instructions	59
8.1.3	Cleaning Procedures	60
8.2	Maintenance	61
8.2.1	Maintenance Staff	61
8.2.2	Safety Instructions	61
8.2.3	Maintenance Procedures	62
9	INSPECTIONS	63
9.1	Inspections in Accordance with DIN EN 50177: 2010	63
9.2	Inspections in Accordance with DIN EN 50050-2: 2014	67
10	DISASSEMBLY AND DISPOSAL	69
10.1	Disassembly	69
10.2	Disposal	70

Table of Contents

11	TROUBLESHOOTING AND RECTIFICATION	71
11.1	Warnings E01-E04	72
11.2	Faults	74
12	ACCESSORIES	77
12.1	Connection Cables	77
12.2	Wall Mount	77
12.3	Recipe Sticker	78
13	SPARE PARTS	79
13.1	How Can Spare Parts Be Ordered?	79
13.2	EPG-SPRINT X Control Unit	80
14	DECLARATION OF WARRANTY AND CONFORMITY	81
14.1	Important Notes Regarding Product Liability	81
14.2	Warranty Claim	81
14.3	CE Declaration of Conformity	82
14.4	EC Type Examination Certificate	83
14.5	FM Approval	84
	DEVICE CONFIGURATION APPENDIX	85
A1	Setting Example: Parameter C11	87
A2	Setting Example: Parameter C13	89
A3	Table of Parameters	91
A4	Spray Current Reset when using Field Controllers	96
	BRIEF DESCRIPTION	98
1	Changing Parameters	99
2	Calling / Changing / Saving Recipes 1-4	99
3	Calling / Changing / Saving Recipes 5-50	99

1 GENERAL INFORMATION

1.1 PREFACE

The operating manual contains information about safely operating, maintaining, cleaning and repairing the device.

The operating manual is part of the device and must be available to operating and service staff.

Operating and service staff should be instructed according to the safety instructions.

The device may only be operated in compliance with this operating manual.

This equipment can be dangerous if it is not operated according to the instructions in this operating manual.

1.2 WARNINGS, NOTICES, AND SYMBOLS IN THIS OPERATING MANUAL

Warning instructions in this operating manual highlight particular dangers to users and to the device and state measures for avoiding the hazard. These warning instructions fall into the following categories:

Danger - immediate risk of danger.
Non-observance will result in death or serious injury.

	DANGER
	<p>This notice warns you of a hazard! Possible consequences of not observing the warning instructions. The signal word indicates the hazard level.</p> <p>→ The measures for preventing the danger and its consequences.</p>

Warning - possible imminent danger.
Non-observance may result in death or serious injury.

	WARNING
	<p>This notice warns you of a hazard! Possible consequences of not observing the warning instructions. The signal word indicates the hazard level.</p> <p>→ The measures for preventing the danger and its consequences.</p>

Caution - a possibly hazardous situation.
Non-observance may result in minor injury.

	CAUTION
	<p>This notice warns you of a hazard! Possible consequences of not observing the warning instructions. The signal word indicates the hazard level.</p> <p>→ The measures for preventing the danger and its consequences.</p>

Notice - a possibly hazardous situation.
Non-observance may result in material damage.

NOTICE
<p>This notice warns you of a hazard! Possible consequences of not observing the warning instructions. The signal word indicates the hazard level.</p> <p>→ The measures for preventing the danger and its consequences.</p>

Note - provides information about particular characteristics and how to proceed.

1.3 LANGUAGES

The operating manual is available in the following languages:

German	2327591	English	2329371
French	2330847	Italian	2330848
Spanish	2330849	Russian	2333349
Chinese	2333350	Hungarian	2341081
Portuguese	2342815	Swedish	2344282
Slovakian	2348856	Danish	2348523

1.4 ABBREVIATIONS

Stk	Number of pieces
Pos	Position
K	Marking in the spare parts lists
Order No.	Order number
ET	Spare part



2 CORRECT USE

2.1 DEVICE TYPE

Universal control unit for controlling electrostatic manual and automatic spray guns

2.2 TYPE OF USE

The EPG-SPRINT X control unit is intended for controlling electrostatic manual and automatic spray guns of type A-P (2 mJ) according to DIN EN 50177.

	 WARNING
	<p>Incorrect use! Risk of injury and damage to the device.</p> <p>→ Only connect original Wagner spray guns to the EPG-SPRINT X control unit.</p> <p>→ The PEM-C3R and PEM-T3R manual spray guns cannot be connected to the EPG-SPRINT X control unit.</p>

2.3 USE IN POTENTIALLY EXPLOSIVE AREAS

The EPG-SPRINT X control unit is intended for use with powder spray guns of types A-P up to 2 mJ in accordance with the prototype test PTB 12 ATEX 5001.

The EPG-SPRINT X control unit may be used in the dust explosion zone (Zone 22) under the following conditions:

- Control unit correctly fitted in rack.
- Rack correctly and securely sealed on rear with associated cover.
- All connections not needed (mains output, remote control) are sealed with dust protection caps.



2.4 SAFETY PARAMETERS

WAGNER accepts no liability for any damage arising from incorrect use.

- Electrostatic spray equipment may only be operated in an intact condition, damaged devices must be decommissioned immediately and repaired.
- Use the device only to work with the products recommended by WAGNER.
- Operate only the device as a whole.
- Do not deactivate safety fixtures.
- Spare parts and accessories may have safety-relevant properties:
Use only WAGNER original spare parts and accessories.

The use of the control unit is only permissible under the following conditions:

- the operating staff have previously been trained on the basis of this operating manual,
- the safety regulations listed in this operating manual are observed,
- the operating, maintenance and repair information in this operating manual is observed,
- and the statutory requirements and accident prevention regulations standards in the country of use are observed.

2.5 REASONABLY FORESEEABLE MISUSE

- Coating work pieces which are not grounded
- Use of defective components and accessories
- Use with not permissible powder coating guns

2.6 RESIDUAL RISKS

Residual risks are risks which cannot be excluded even in the event of correct use. If necessary, warning and prohibition signs at the relevant points of risk indicate residual risks.

Residual risk	Source	Consequences	Specific measures	Lifecycle phase
Skin contact with powder lacquers and cleaning agents	Handling powder lacquers and cleaning agents	Skin irritation, allergies	Wear protective clothing, observe safety data sheets	operation, maintenance, disassembly
Powder lacquer in air outside the defined working area	Lacquering outside the defined working area	Inhalation of substances hazardous to health	Observe working and operating instructions	operation, maintenance

3 IDENTIFICATION

3.1 EXPLOSION PROTECTION IDENTIFICATION IN ACCORDANCE WITH ATEX

The device is suited for use in potentially explosive areas, in accordance with Test Certificate PTB 12 ATEX 5001.

CE₀₁₀₂ Ex II 3(2)D IP 64 80 °C

CE: European Communities

0102: Number of notified body which issues the recognition of quality assurance in production.

Ex: Symbol for explosion protection

II: Device class II

3: Category 3 (Zone 22)

(2): Impact on equipment of category 2

D: Ex-atmosphere dust

IP64: Protection class 64

80 °C: Temperature class: maximum surface temperature < 80 °C; 176 °F

3.2 PERMISSIBLE DEVICE COMBINATIONS

The following powder spray guns may be connected to the EPG-SPRINT X:

Manual spray guns	
● Corona spray gun	PEM-X1, PEM-X1 CG, PEM-C3, PEM-C4, PEM-C4-Ergo
● Tribo spray gun	PEM-T3

Automatic spray guns	
● Corona spray gun	PEA-C3, PEA-C4
● Corona spray gun	PEA-C3XL, PEA-C4XL
● Tribo spray gun	PEA-T3
● Tribo spray gun	PEA-T3XL

Older or other gun types may only be connected to the control unit after first checking their suitability with Wagner.

For permissible device combinations for the USA and Canada, see Chapter 14.5 "FM Approval".

4 GENERAL SAFETY INSTRUCTIONS

4.1 SAFETY INSTRUCTIONS FOR THE OPERATOR

- Keep this operating manual at hand near the device at all times.
- Always follow local regulations concerning occupational safety and accident prevention.



4.1.1 ELECTRICAL DEVICES AND EQUIPMENT

- To be provided in accordance with the local safety requirements with regard to the operating mode and ambient influences.
- May only be maintained by skilled electricians.
- Must be operated in accordance with the safety regulations and electrotechnical regulations.
- Must be repaired immediately in the event of problems.
- Must be decommissioned if they pose a hazard.
- Must be de-energized before work is commenced on active parts.
- Secure the device against being switched back on without authorization. Inform staff about planned work.
- Observe electrical safety regulations.



4.1.2 STAFF QUALIFICATIONS

- Ensure that the device is operated, maintained, and repaired only by trained persons.

4.1.3 SAFE WORK ENVIRONMENT

- The floor in the working area must be electrostatically conductive (measurements according to EN 1081 and EN 61340-4-1).
- The footwear worn by the operators must comply with the requirements of EN ISO 20344. The measured insulation resistance must not exceed 100 megohms.
- The protective clothing, including gloves, must comply with the requirements of EN ISO 1149-5. The measured insulation resistance must not exceed 100 megohms.
- The powder release must be electrically interlocked with the powder spray system's exhaust air equipment.
- Excess coating product (overspray) must be collected up safely.
- Ensure that there are no ignition sources such as naked flames, sparks, glowing wires, or hot surfaces in the vicinity. Do not smoke.
- Maintain sufficient quantities of suitable fire extinguishers and ensure that they are serviceable.
- The operating company must ensure that an average concentration of powder lacquer in the air does not exceed 50% of the lower explosion limit (LEL = max. permitted concentration of powder to air). If no reliable LEL value is available, the average concentration may not exceed 10 g/m³.



4.2 SAFETY INSTRUCTIONS FOR STAFF

- Always follow the information in this manual, particularly the general safety instructions and the warning instructions.
- Always follow local regulations concerning occupational safety and accident prevention.
- Under no circumstances may people with pacemakers enter the area where the high-voltage field between the spray gun and the work piece to be coated builds up!



4.2.1 SAFE HANDLING OF WAGNER POWDER SPRAY DEVICES

- Do not point spray guns at people.
- Before all work on the device, in the event of work interruptions and functional faults:
 - Switch off the energy/compressed air supply.
 - Secure the spray gun against actuation.
 - Relieve pressure on spray guns and device.
 - In case of functional faults: Identify and correct the problem, proceed as described in the "Fault Rectification" chapter.



4.2.2 GROUNDING THE DEVICE

The electrostatic charge may, in certain cases, give rise to electrostatic charges on the device. This may result in the formation of sparks or flames when discharging.

- Ensure that the device is grounded before each coating process.
- Ground the work pieces to be coated.
- Ensure that all persons inside the working area are grounded, e.g., by wearing electrostatically conductive shoes.
- The functionality of grounding cables must be checked regularly (see EN 60204).



4.2.3 PRODUCT HOSES

- Only use an original Wagner powder hose.



4.2.4 CLEANING



- Before starting cleaning or any other manual work, the high-voltage in the spray area must be shut down and locked to prevent it from being switched back on.
- Lock the compressed air supply and decompress the device.
- Secure the device against being switched back on without authorization.
- Use only electrically conducting and grounded tanks for cleaning fluids.
- Preference should be given to non-flammable cleaning fluids.
- Flammable cleaning liquids may only be used if, after switching off the high-voltage, all high-voltage conducting parts are discharged to a discharge energy of less than 0.24 mJ before they can be accessed.
Most flammable solvents have an ignition energy of around 0.24 mJ or 60 nC.
- The cleaning agent's flash point must be at least 15 K above the ambient temperature.
- Only mobile industrial vacuum cleaners of design 1 (see EN 60335-2) may be used to remove dust deposits.

4.2.5 HANDLING POWDER LACQUERS

- When preparing or processing the powder and cleaning the device, take note of the processing regulations, laid down by the manufacturer of the powder lacquers, being used.
- Take note of the manufacturer's instructions and the relevant environmental protection regulations when disposing of powder lacquers.
- Take the prescribed safety measures, in particular the wearing of safety glasses and safety clothing as well as the use of protective hand cream.
- Use a mask or breathing apparatus if necessary.
- To ensure sufficient protection of health and the environment, only operate the device in a powder booth or on a spray wall with activated ventilation (exhaust air).



4.3 PROTECTIVE AND MONITORING EQUIPMENT

	 WARNING
	<p>Protective and monitoring equipment! Risk of injury and damage to the device.</p> <ul style="list-style-type: none">→ Protective and monitoring equipment must not be removed, modified or rendered unusable.→ Regularly check for perfect functioning.→ If defects are detected on protective and monitoring equipment, the system must not be operated until these defects are remedied.

4.4 SAFETY FEATURE IDENTIFICATION

Plates bearing information for the user have been attached to the work openings of the powder coating booth.

The plate size corresponds to the standard category Ø 100 mm; 3.94 inches.

The label plates, which must be attached, are shown below:



High-voltage!
In the control cabinet:
(25 mm; 0.98 inches)
Voltage before main switch



Danger of crushing!



Explosive atmosphere!



Risk of tripping!



Forbidden for persons
with a cardiac pacemaker!

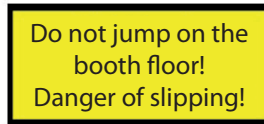

Smoking, fire, and open
flames are prohibited!



Forbidden for unauthorized
persons!





Wear electrostatically
conductive footwear!



Follow the instructions in the
operating manual!

5 DESCRIPTION

5.1 AREAS OF APPLICATION

	 WARNING
	<p>Incorrect use! Risk of injury and damage to the device.</p> <p>→ Only connect original Wagner spray guns to the EPG-SPRINT X control unit.</p> <p>→ The PEM-C3R and PEM-T3R manual spray guns cannot be connected to the EPG-SPRINT X control unit.</p>

The EPG-SPRINT X control unit can be used as a stand-alone unit in manual coating systems or can be connected to the PrimaTech automatic system together with other units.

- When a Corona gun is connected, Corona current scale and the high-voltage supply and control unit are active.
- When a Tribo gun is connected, the Tribo current scale is activated, while the high-voltage supply and control unit are deactivated.

The control unit recognizes if a manual or automatic spray gun is connected. If an automatic gun is connected, then the control unit can only be controlled via the CCM Prima interface.



5.2 TECHNICAL DATA

Dimensions:	
Height	136 mm; 5.35 inches
Width	270 mm; 10.63 inches
Depth (without operating elements)	200 mm; 7.87 inches
Weight	3.3 kg; 7.28 lbs

Electrical:	
Mains (AC)	85 VAC-250 VAC
Frequency	47 Hz-440 Hz
Input power	maximum 40 W
Output voltage	maximum 22 Vpp
Output current	maximum 0.9 A
High-voltage	10-100 kV (adjustable in 1 kV steps)
Corona current limitation	5 μ A-120 μ A (adjustable in 1 μ A steps)
Tribo current measuring range	0 μ A-15 μ A
Tribo current limitation	0 μ A-5 μ A (adjustable in 0.1 μ A steps)
Tribo current cut off	greater than 12 μ A (ATEX: switching off of the unit)
Protection class:	IP 64
Ex zone	II 3(2)D 80 °C; 176 °F (Zone 22)

Pneumatic:	
Air input pressure	0.6-0.8 MPa; 6-8 bar; 87-116 psi
Air volume	maximum 15 m ³ /h
Sum of dosing and feed air	1-6 m ³ /h
Gun air	0.05-4.0 m ³ /h
Required compressed air quality as per ISO 8573.1	3.5.2
Connection hose diameter	8 mm; 0.315 inches

Ambient conditions:	
Operating temperature range	5-45 °C; 41-113 °F

	 WARNING
	<p>Outgoing air containing oil! Risk of poisoning if inhaled.</p> <p>→ Provide compressed air free from oil and water (Quality Standard 3.5.2 according to ISO 8573.1) 3.5.2 = 5 µm / +7 °C; 44.6 °F / 0.1 mg/m³.</p>

<h2>NOTICE</h2>
<p>Compressed air quality, accessories Danger of damage to the device.</p> <p>→ Operate the control unit only with the prescribed compressed air quality. → Only use the control unit with original Wagner accessories. → Non-observance of these conditions results in the warranty expiring!</p>

Ambient conditions:

If low-melting powders are used, the ambient temperature may have to be lower than 30 °C; 86 °F.

Volume measures:

for volumes specified in Nm³ (standard cubic meters). One cubic meter of a gas at 0 °C and 1.013 bar is called norm cubic meter.

5.3 PERMITTED ACCESSORIES

Only the accessories listed in the chapter "Accessories" of this operating manual may be connected to the EPG-SPRINT X control unit.

The accessories listed in the chapter "Accessories" were included in the EC type examination and are approved for use with the control unit.

5.4 SCOPE OF DELIVERY

Stk	Order No.	Designation
1	2324731	EPG-SPRINT X (for manual and automatic systems)
The standard equipment includes:		
1	2327595	Conformity certificate
1	2327591	Operating manual, German
1	see Chapter 1.3	Operating manual in local language

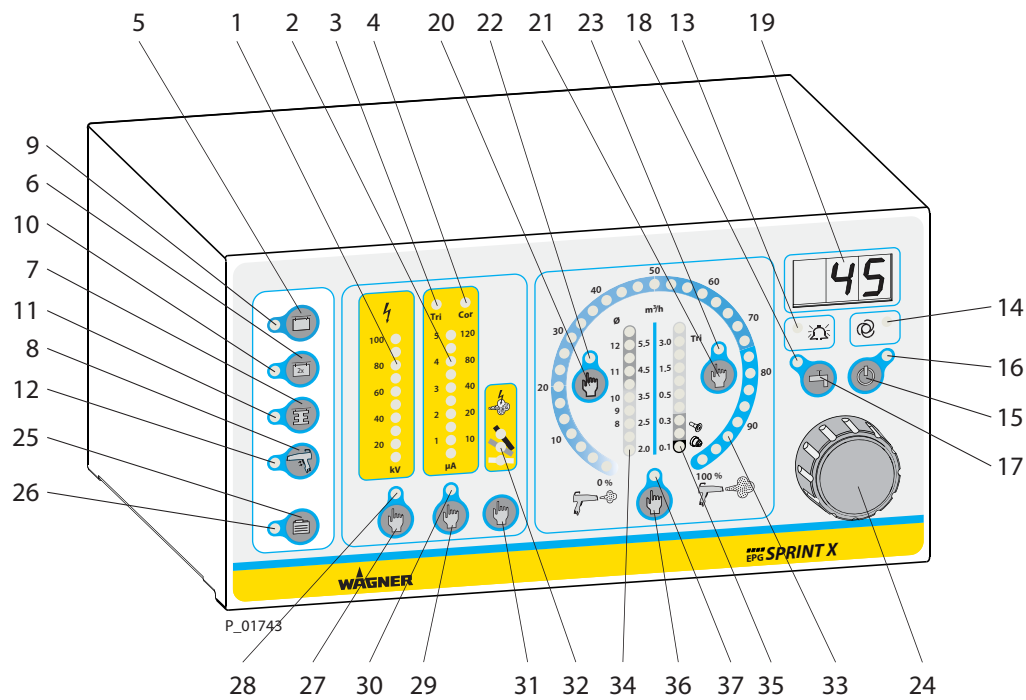
5.5 OPERATING ELEMENTS**5.5.1 OPERATING ELEMENTS FRONT SIDE****1 Illuminated display: "High-voltage"**

- Lights up green
- Display range: 0-100 kV
Resolution 10 kV
- Single LED display: Nominal voltage
- Bar display: Working voltage

2 Illuminated display: "Corona or Tribo Current"

- Lights up green

Tribo scale:

- When a Tribo gun is connected and selected
- Bar display: When powder feed is activated
- Display range: 0-5 μA
Resolution: 0.5 μA

Corona scale:

- When a Corona gun is connected and selected
- Display and adjusting range: 0 [5]-120 μA ,
0 [5]-20 μA Resolution 5 μA
20-40 μA Resolution 10 μA
40-120 μA Resolution 20 μA
- Single LED display: "Trigger Point of Current Limitation"
- Bar display: Corona current

- 3 Display: "Tribo Gun"**
 - Lights up when a Tribo gun is connected and selected
- 4 Display: "Corona Gun"**
 - Lights up when a Corona gun is connected and selected
- 5 Push button: recipe for "Surface Parts"**
- 6 Push button: recipe for "Second Coating"**
- 7 Push button: recipe for "Profiles"**
- 8 Push button: recipe for "Double Click"**
 - To access the recipe, press the trigger lever on the spray gun twice in quick succession and hold it down
- 9 Display LED: recipe for "Surface Parts"**
 - Lights up green when the recipe for surface part is selected
- 10 Display LED: recipe for "Second Coating"**
 - Lights up green when the recipe for "Second Coating" is selected
- 11 Display LED: recipe for "Profiles"**
 - Lights up green when the recipe for profile part is selected
- 12 Display LED: recipe for "Double Click"**
 - Lights up green, when the recipe for "Double Click" is selected
- 13 Display LED: "Fault"**
 - Lights up, when there is a fault on the device
- 14 Display LED: "Automatic Gun"**
 - Lights up, when an automatic gun is connected
- 15 Push button: "Standby"**
 - To switch into standby mode
 - High-voltage and powder feed cannot be activated in this mode
 - To reactivate normal mode, press the button again
- 16 Display LED: "Standby"**
 - Lights up when the unit is in standby mode
- 17 Push button: "Purge"**
 - To activate the injector and the hose rinsing

18 Display LED: "Purge"

- Lights up blue, when the purge function is activated

19 Display LED: 7 segments, three-digit number

- Indicates the exact value depending on the activated function:
"Total air volume; atomizing, ionizing and Tribo air; additional recipes; high-voltage;
current limitation; powder quantity"
- Display showing error number in the event of warnings and malfunctions

20 Push button: "Total Air Volume"

- To activate the function, the value is precisely adjusted with rotary controller 24 and is indicated in LED display 19
- Adjusting range: 1-6 m³/h
- Resolution: 0.05 m³/h

21 Push button: "Atomizing, Ionizing and Tribo Air"

- To activate the function, the value is precisely adjusted with rotary controller 24 and is indicated in LED display 19
- Adjusting range: 0.05-4 m³/h
- Resolution: 0.05 m³/h

22 Display LED: "Overall Air"

- Lights up yellow, when the setting "Overall Air" is selected

23 Display LED: "Atomizing, Ionizing and Tribo Air"

- Lights up yellow, when the setting "Atomizing, Ionizing and Tribo Air" is selected

24 Universal control dial

- Dynamic digital control dial with 32 positions per revolution
- Adjustment speed is proportional to rotational speed
- Used to set: "Total air volume; atomizer, ionizer and Tribo air; additional recipes; high-voltage; current limitation; powder quantity"
- For setting parameter values in configuration mode

25 Push button: "Additional Recipes"

- To activate the function, the additional recipe is set with the rotary controller 24 and is indicated in the LED display 19
- Selection of the recipes 5 to 50

26 Display LED: "Additional Recipes"

- Lights up yellow, when an additional recipe is selected

27 Push button: "High-voltage"

- To activate the function, the high-voltage is set with Rotary Controller 24 and is indicated in LED Display 19
- Adjusting range: 10-100 kV
- Resolution: 1 kV

28 Display LED: "High-voltage"

- Lights up yellow. The high-voltage is selected and can be adjusted using rotary controller 24

29 Push button: "Current Limitation"

- To activate the function, the current limitation is set with rotary controller 24 and is indicated in LED display 19
- Adjusting range: 5-120 μ A
- Resolution: 1 μ A

30 Display LED: "Current Limitation"

- Lights up yellow. The current limitation is selected and can be adjusted using rotary controller 24

31 Push button: "Characteristic Slope"

- To switch the characteristic slope
- Display with LED 32

32 Display LED: "Characteristic Slope"

- Lights up green
- Lower LED characteristic curve, flat
- Middle LED characteristic curve, medium
- Upper LED characteristic curve, steep

33 Illuminated display: "Powder Quantity"

- Lights up green
- Display range: 0-100%
- Resolution: 3.33%
- Single LED display: Set point (high-voltage and powder are deactivated)
- Bar display: Actual value (high-voltage and powder are activated)

34 Illuminated display: "Total Air Volume"

- Lights up green
- Display range: 1-6 m^3/h
- Resolution: 0.2-0.5 m^3/h
- Single LED display: Set point (high-voltage and powder are deactivated)
- Bar display: Actual value (high-voltage and powder are activated)

35 Illuminated display: "Atomizing, Ionizing and Tribo Air Volume"

- Lights up green
- Display range: 0.1-4 m^3/h
- Resolution: 0.1-1.0 m^3/h
- Single LED display: Set point (high-voltage and powder are deactivated)
- Bar display: Actual value (high-voltage and powder are activated)

36 Push button: "Powder Quantity"

- To activate the function, the powder quantity is set with rotary controller 24 and is indicated in LED display 19.
- Adjusting range: 1-100%
- Resolution: 1%

37 Display LED: "Powder Quantity"

- Lights up yellow, when the powder quantity is selected

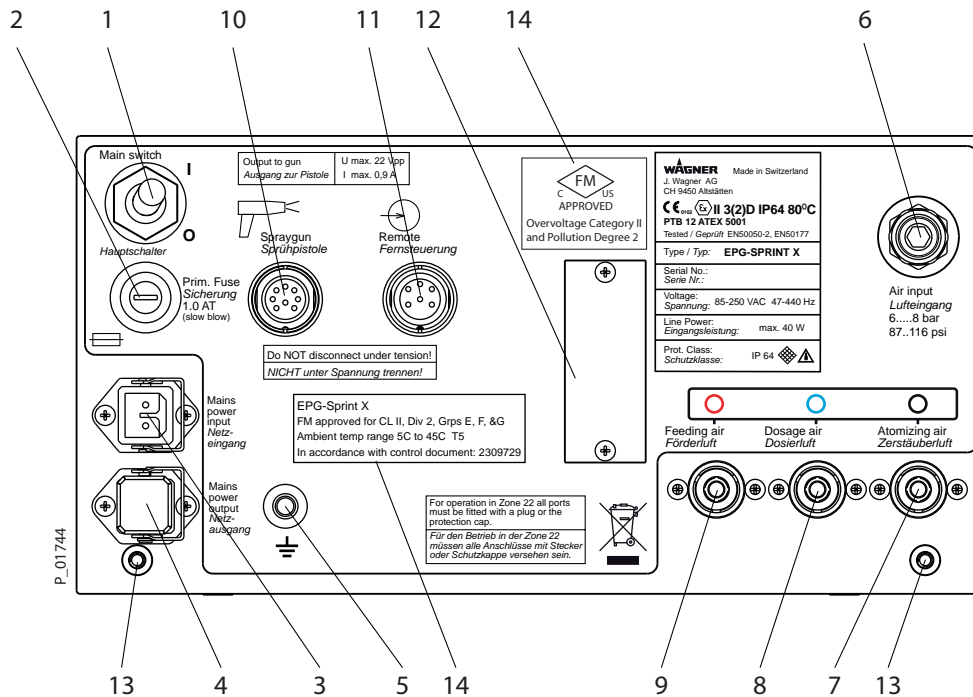
5.5.2 CONNECTIONS ON THE REAR SIDE OF THE EPG-SPRINT X**1 Mains supply switch**

0 = The control unit is deactivated

I = the control unit is activated

2 Primary fuse

- 1 Ampere slow-acting

3 Mains input terminal

- Universal input: 85 V AC - 250 V AC

4 Mains power output

- Direct, not through the mains switch
- To loop the mains through the PrimaTech system

5 Knurled nut

- To connect the signal ground

6 Compressed air inlet

- Pressure range: 0.6-0.8 MPa; 6-8 bar; 87-116 psi
- Air volume: maximum 15 m³/h
- Connection hose diameter 8 mm; 0.315 inches

7 Compressed air outlet for additional air

- With a Corona gun: Atomizing air
- With a Tribo gun: Tribo air

8 Compressed air outlet for dosing air

- For the powder injector

9 Compressed air outlet for feed air

- For the powder injector

10 Gun connection

- To connect a Corona or Tribo gun

11 Connection for the CCM Prima

- For connecting to the CCM Prima when fitting in a PrimaTech automatic system

12 Cover of the service connection

- For Wagner service personnel only!



13 Fixations

- For screwing to the rack

14 FM-Identification

6 ASSEMBLY AND COMMISSIONING

6.1 TRAINING ASSEMBLY/COMMISSIONING STAFF

	 WARNING
	<p>Incorrect installation/operation! Risk of injury and damage to the device.</p> <ul style="list-style-type: none"> → The commissioning staff must have the technical skills to safely undertake commissioning. → When commissioning and for all work, read and follow the operating manual and safety regulations for the additionally required system components.

6.2 STORAGE CONDITIONS

Until the point of assembly, the control unit must be stored in a dry location, free from vibrations and with a minimum of dust. The control unit must be stored in closed rooms. The air temperature at the storage location must be between 5 - 45 °C; 41 - 113 °F. The relative air humidity at the storage location must not exceed 75%.

6.3 INSTALLATION CONDITIONS

The air temperature at the assembly site must be between 5 - 45 °C; 41 - 113 °F. Depending on the powder lacquer used, the maximum permissible ambient temperature for reliable operation can be significantly below +40 °C; 104 °F. The relative air humidity at the assembly location must not exceed 75%.

6.4 CONNECTING THE MANUAL GUN

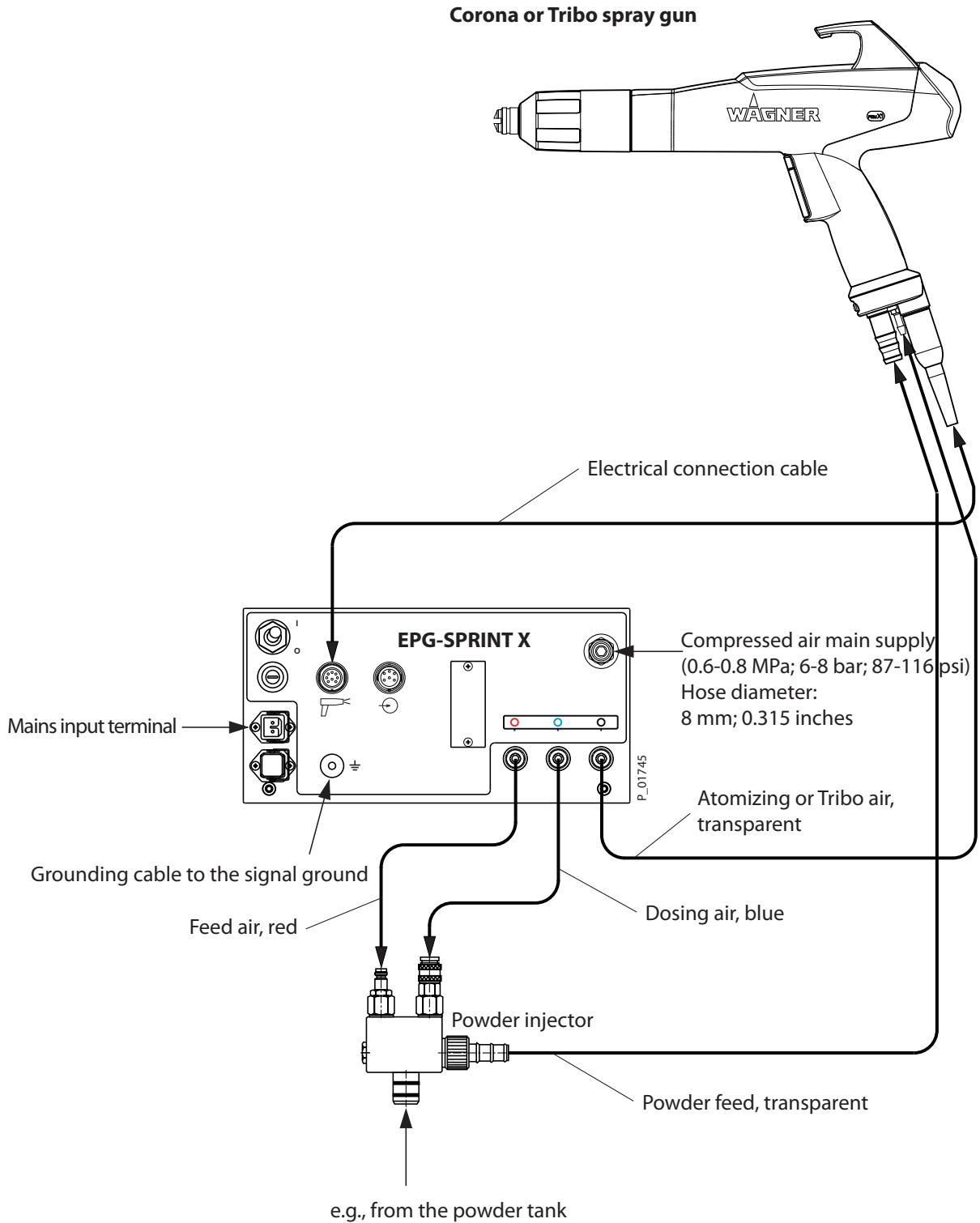



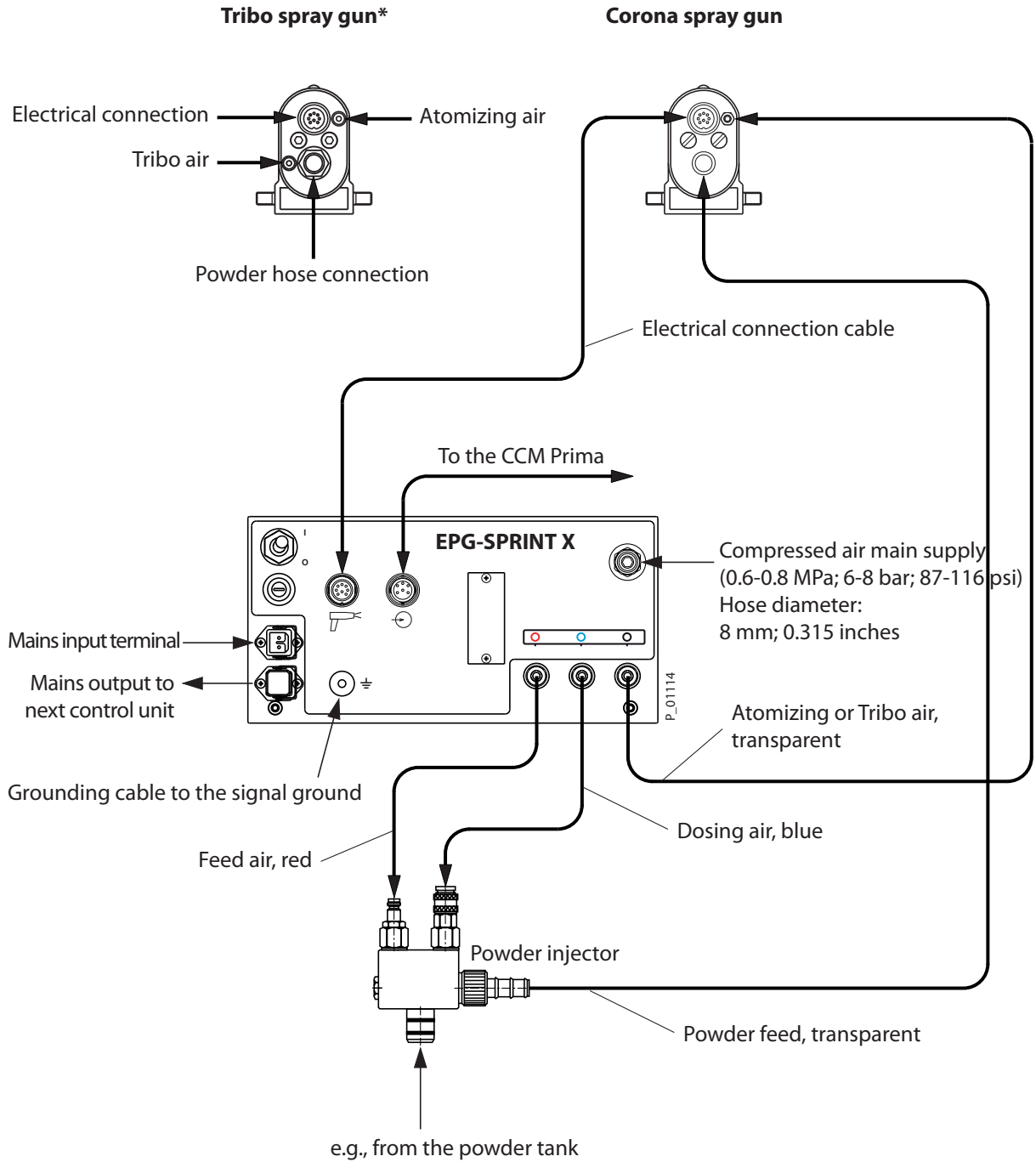

6.5 CONNECTING THE AUTOMATIC GUN



* A Y distributor (Order No. 9990149) is needed to divide the different types of air.

6.6 GROUNDING

	 DANGER
	<p>No Grounding! Risk of explosion and risk of electric shock.</p> <p>→ Electrostatic control units and the associated spray equipment may only be connected to mains supplies with a protective conductor connection (PE conductor)!</p>

	 WARNING
	<p>Heavy powder mist if grounding is insufficient! Danger of poisoning. Insufficient paint application quality.</p> <p>→ Ground all device components. → Ground the work pieces to be coated.</p>

For safety reasons, the control unit must be properly grounded. The ground connection to the energy supply (socket) takes the form of the mains connection cable's protective conductor, while that to the work piece / system is via the knurled screw on the rear of the control unit. Both connections are absolutely essential. If installed correctly as described above, the spray gun is grounded via the gun cable between the control unit and spray gun.

Good grounding of the work piece is also necessary for optimum powder coating.

A poorly grounded work piece causes:

- dangerous electric charging of the work piece,
- very poor wrap-around,
- uneven coating,
- back spraying to the spray gun, i.e., contamination.

Prerequisites for perfect grounding and coating are:

- Clean work piece suspension.
- Grounding of spray booth, conveyor system and suspension on the building side in accordance with the operating manuals or the manufacturer's information.
- Grounding of all conductive parts within the working area.
- The grounding resistance of the work piece may not exceed 1 MΩ (megohm). (Resistance to ground measured at 500 V or 1000 V).

- The footwear worn by the operators must comply with the requirements of EN ISO 20344. The measured insulation resistance must not exceed 100 MΩ (megohms).
- The protective clothing, including gloves, must comply with the requirements of EN ISO 1149-5. The measured insulation resistance must not exceed 100 MΩ (megohms).

Sparks between conveyor, conveyor hooks (hangers) and work piece can occur if electric contact points between conveyor, conveyor hooks (hangers) and work piece are not sufficiently cleaned and therefore the work pieces are not sufficiently grounded!

These sparks can cause heavy radio frequency interference (EMC).

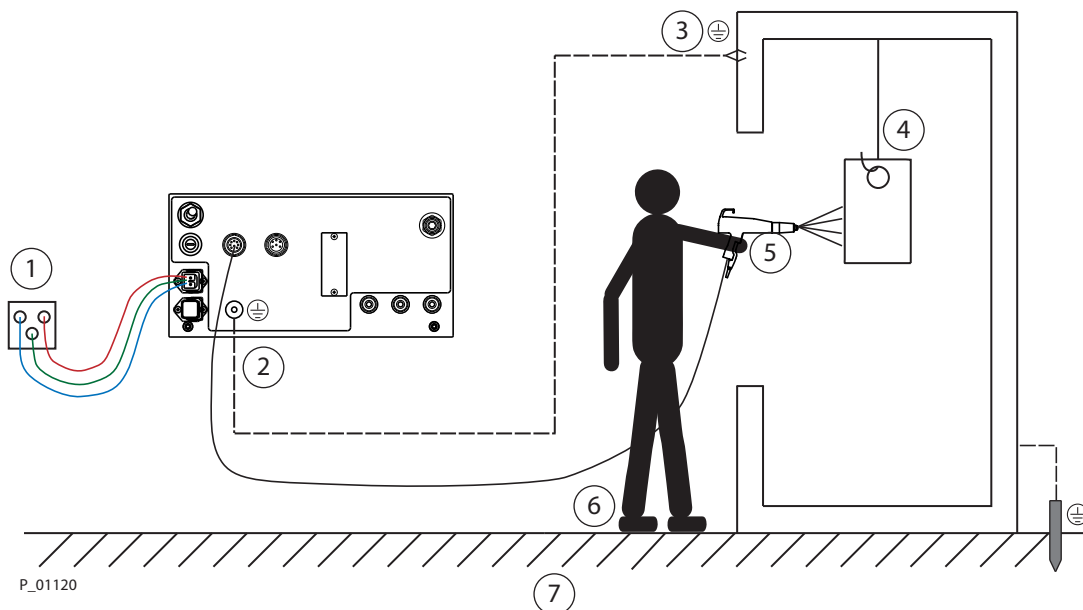

6.6.1 GROUNDING THE POWDER COATING SYSTEM





- 1 Only use mains cables with grounding strand!**
- 2 Connect grounding cable with booth and signal ground!**
- 3 Connect grounding cable to an uncoated metal part of the booth!**
- 4 Remove all paint from hooks and other hanger parts!**
- 5 Do not wear non-conducting gloves!**
- 6 Wear electrostatically conductive footwear!**
- 7 The floor must be electrostatically conductive!**

7 OPERATION

7.1 TRAINING THE OPERATING STAFF

	 WARNING
	<p>Incorrect operation! Risk of injury and damage to the device.</p> <ul style="list-style-type: none"> → The operating staff must be qualified to operate the entire system. → Before work commences, the operating staff must receive appropriate system training.

7.2 SAFETY INSTRUCTIONS

	 WARNING
	<p>Incorrect operation! Risk of injury and damage to the device.</p> <ul style="list-style-type: none"> → If contact with powder products or cleaning agents causes skin irritation, appropriate precautionary measures must be taken, e.g., wearing protective clothing. → The footwear worn by operating staff must comply with EN ISO 20344. The measured insulation resistance must not exceed 100 megohms. → The protective clothing, including gloves, must comply with EN ISO 1149-5. The measured insulation resistance must not exceed 100 megohms.

NOTICE

Damage to the device!

- The control unit must be connected and grounded according to the directions in chapter 5.
- After switching on the unit, wait for the start up phase to be completed. A function test is performed in the start up phase. At the end of the tests, the connected gun type is detected and displayed.
- Do not actuate the trigger on a manual spray gun in the start-up phase, if the gun is used as a single device in a manual coating system. If the trigger is actuated, the control unit will detect it as an automatic gun and wait for the actuation signal from CCM Prima. The unit cannot be switched on.

7.3 PREPARATIONS FOR COMMISSIONING

7.3.1 OPERATING MODES

The EPG-SPRINT X supports the following operating modes (starting with software version B200):

- Manual gun mode (manual system with vibrator control)
- Automatic gun mode (remote interface for external control of the module)
- Manual gun mode with external control (remote interface with external release (required for coating and cleaning) and for external control of cleaning function)

In the first two listed operating modes, the configuration parameter C26 must be set to OFF (factory setting). The operating mode is automatically recognized by the control unit (parameter C26 must be set to "OFF", see Chapter 7.3.2).

7.3.2 GUN RECOGNITION

NOTICE

Functional faults!

- Do not operate the spray gun's trigger while the control unit is being switched on and is powering up.

The EPG-SPRINT X control unit automatically detects whether a manual or automatic gun is connected to the control unit (parameter C26 must be set to "OFF"). It does this by checking whether the trigger switch is activated when it is switched on.

- If the trigger switch is pressed, the gun is an automatic one. The powder feed is switched on and off by a primary controller (CCM 2007; CCM Prima or another original Wagner device for controlling the EPG-SPRINT X).
- If the trigger switch is not pressed, the gun is a manual one. The powder feed is switched on and off with the gun's manual trigger.

7.3.3 MANUAL GUN MODE WITH EXTERNAL CONTROL

Application is the recoating of work pieces in an automatic coating system. The recoating is done with a manual gun, but the powder supply is done by the powder center of the automatic system. The EPG-SPRINT X must receive a release signal via the remote interface so that the device may clean and coat. The cleaning function (continuous purging) can also be controlled externally.

Display on device:

● "Automatic gun" LED flashes quickly	No release signal is present
● "Automatic gun" LED is dark	Release signal is present

This operating mode is available starting with software version B200. The function must be selected specifically via configuration parameter C26.

7.3.4 BASIC AND FACTORY SETTINGS

The EPG-SPRINT X control unit is factory-configured for operation with Corona manual or automatic guns. Consequently, the control unit can be used in a manual system or PrimaTech automatic system without any further settings being required.

However, if the control unit is used with a Tribo manual or automatic gun, the gun type must be changed. This change is effected in the configuration settings.

For all other settings, configurations and special functions, please refer to the chapter "Device Configuration".

7.4 RECIPES

Recipes are used to avoid lengthy adjustment work when changing powder or work piece. All parameters relevant for coating a work piece are combined and stored under a recipe number instead.

If required, these can then be called up using the recipe buttons.

With the EPG-SPRINT X, a recipe comprises the following parameters:

Total air volume (feed and dosing air volume)	[m ³ /h]
Powder quantity	[%]
Atomizing air/Tribo air	[m ³ /h]
High-voltage	[kV]
Current limitation	[μA]
U/I characteristic curve	[Standard, medium, soft]

The EPG-SPRINT X control unit has 50 pre-defined recipes. 4 of these can be selected directly using buttons 5-8 and the remaining 46 by pressing the "Additional Recipes" button 25 above the rotary controller 24. All recipes can be adapted and stored by the user to suit individual requirements.

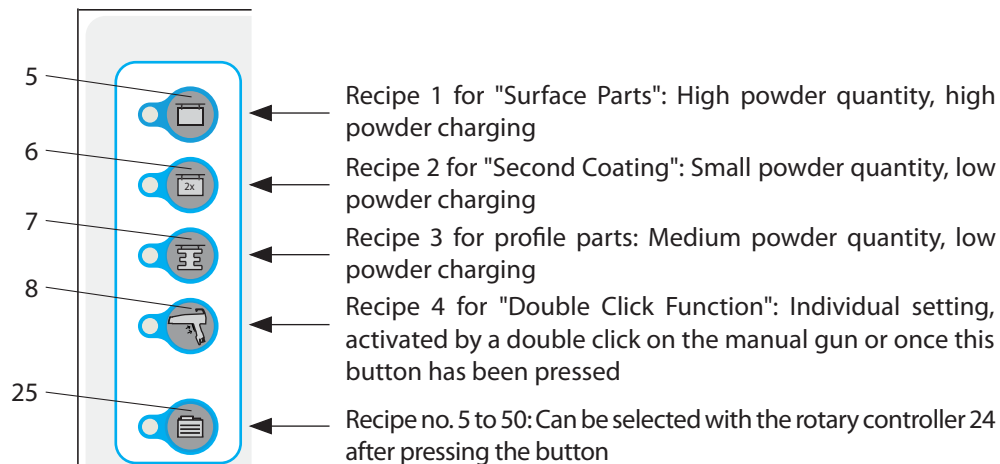

P_01746

7.4.1 "DOUBLE CLICK" RECIPE (HIGH DYNAMIC REMOTE)

This function is used to change quickly to another recipe during a coating operation. The operator can access a previously set recipe by double-clicking on the trigger lever on the spray gun, for example to recoat parts using different parameters (high-voltage, current limitation, air volumes etc.).

To access the function, press the trigger lever on the spray gun twice in quick succession and hold down. Upon releasing the trigger, the original recipe will be returned to.

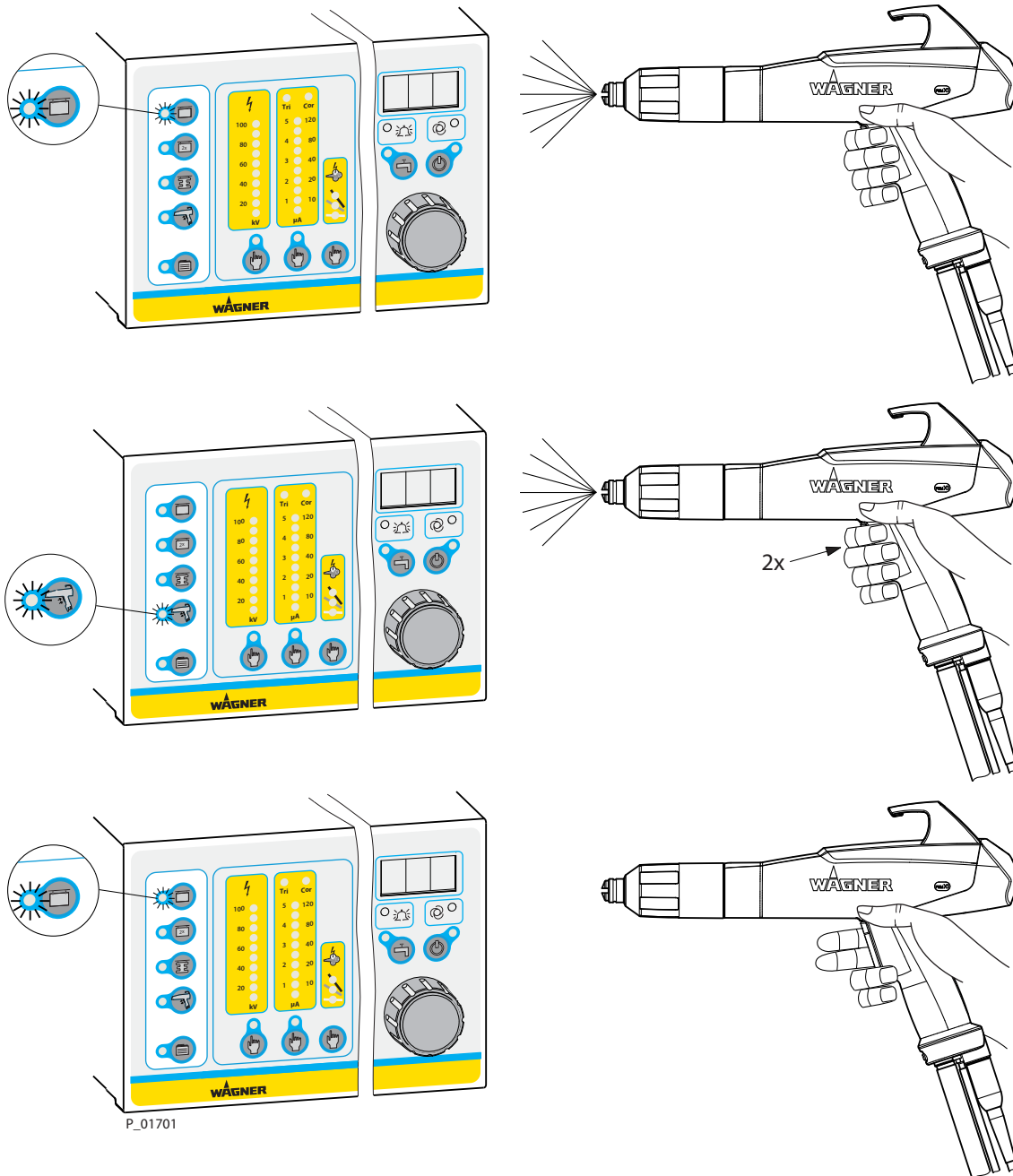

P_01701

7.5 AIR HIGH OUTPUT MODE (HIGH POWDER OUTPUT)

With the EPG-SPRINT X, you can combine the feed and atomizing air to obtain a higher feed air volume. A high powder volume however still depends on other factors. The length of the suction hose and the length and diameter of the powder hose also affect the maximum powder volume.

7.5.1 COMBINING THE AIR OUTPUTS

A Y piece (Order No. 9990149) is needed to combine the feed and atomizing air.

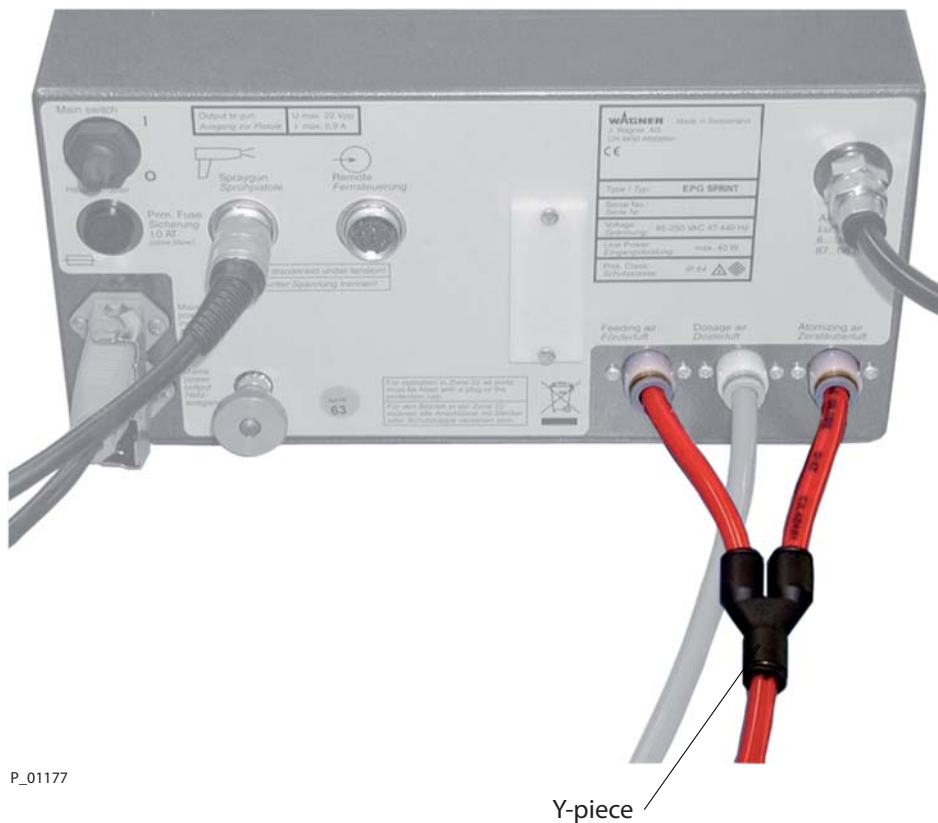

P_01177

Y-piece

Attention:

- The atomizing air is not available in this mode.
- Warning messages 1-3 "Insufficient Feed Air", "Insufficient Dosing Air", "Insufficient Atomizing Air" are deactivated in this mode.

7.5.2 ACTIVATING HIGH OUTPUT MODE (C17)

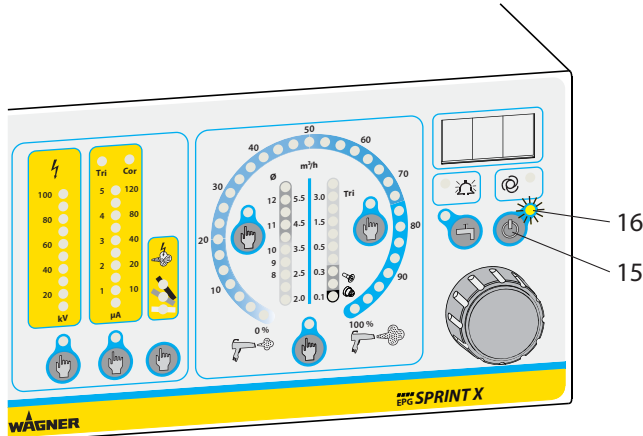

Procedure:

1. To access special device configuration, switch the unit to "Standby" with the "Standby" button 15. The yellow "Standby" LED 16 lights up.

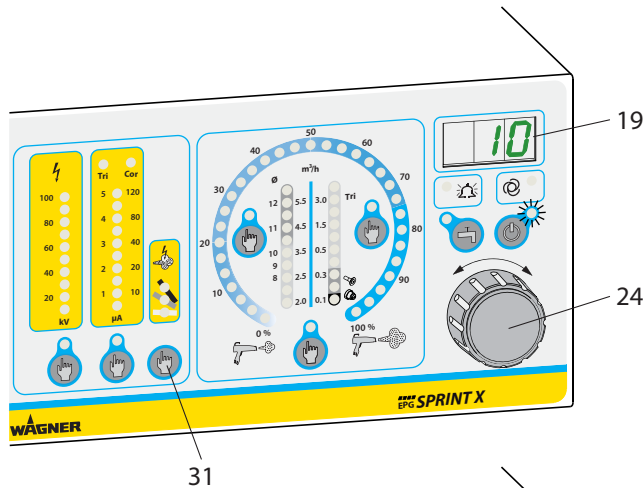

2. Press "Characteristic Slope" button 31 and hold it down.
3. Turn the universal rotary controller 24 with the other hand until the LED display 19 shows the number "10". Then release the "Characteristic Slope" button 31. The device is now in configuration mode. The scrolling text "Configuration" is displayed.

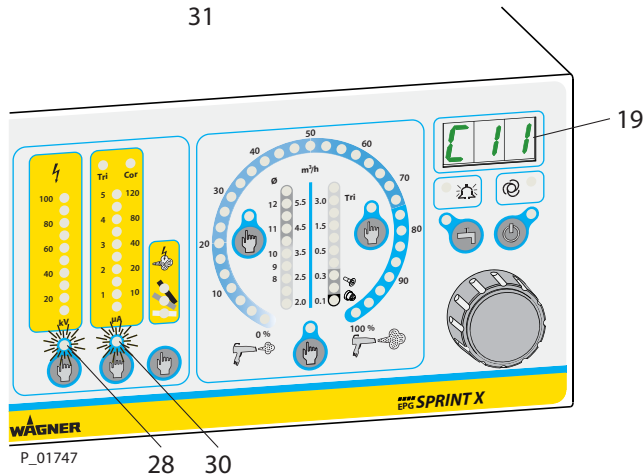

4. The LED display 19 now shows the first configuration setting C11. At the same time, the two yellow LED displays "High-voltage" 28 and "Spray Current" 30 will flash.

P_01747

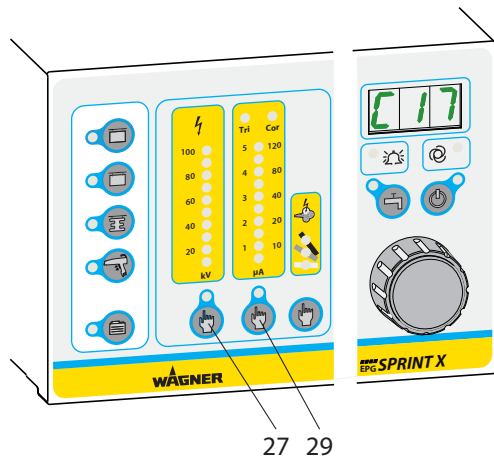

5. Use "High-voltage" button 27 or "Current Limitation" button 29 to select parameter C17.

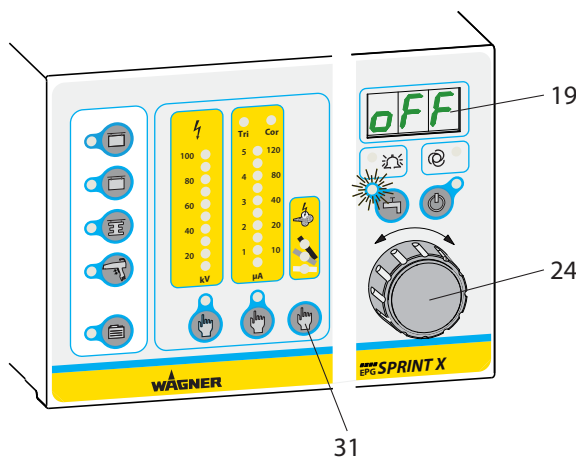

6. The value set for parameter C17 is displayed by pressing "Characteristic Slope" button 31 in LED display 19.

- off = High feed air volume switched off
- on = High feed air volume switched on

To change the value to "on", turn universal rotary controller 24 one step clockwise.

To change the value to "off", turn universal rotary controller 24 one step anticlockwise.

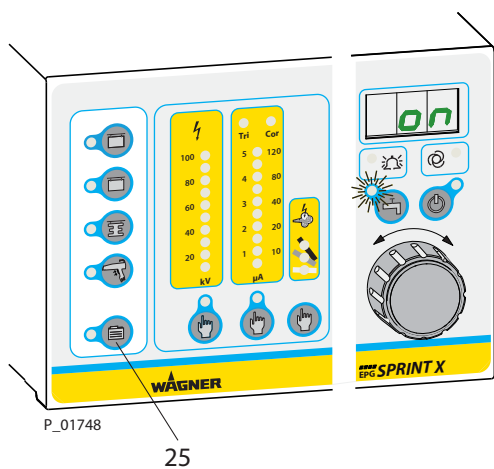

7. To save the "on" setting, press "Additional Programs" button 25 for approx. 2 seconds. LED display 19 switches back to display C17.

P_01748

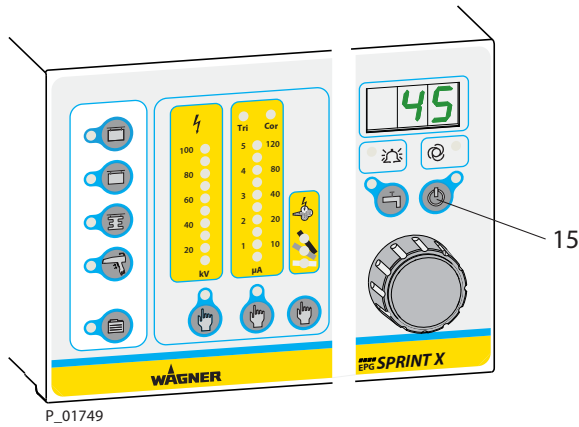

P_01749

8. To exit configuration mode, press the "Standby" button 15 twice.
The control unit is now in the operating mode with high powder flow switched on.
This setting is "global" and applies in all recipes.

7.6 CHANGING AND SAVING RECIPES

7.6.1 RECIPE NO. 1-4

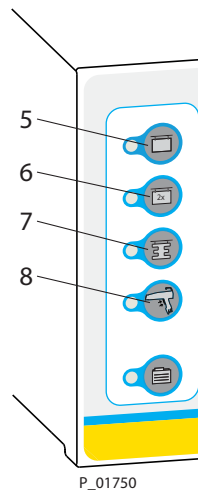

Recipes 1-4 can be selected and saved directly using recipe buttons 5-8. Once the recipe required has been called up, the individual coating parameters can be called up and changed using the corresponding selection buttons. Descriptions of the individual parameters are provided in chapters 7.7.1-7.7.8. When a parameter is changed, the LED on the left of the recipe button flashes to indicate that a parameter value has been changed.

The process for saving parameters is described below.

- To reuse the originally set values, press the corresponding recipe button briefly. The modified values are not taken over.
- To save the modified values, press the appropriate recipe button and hold for approx. 2 seconds until the LED beside the button flashes quickly. The modified values are then saved.

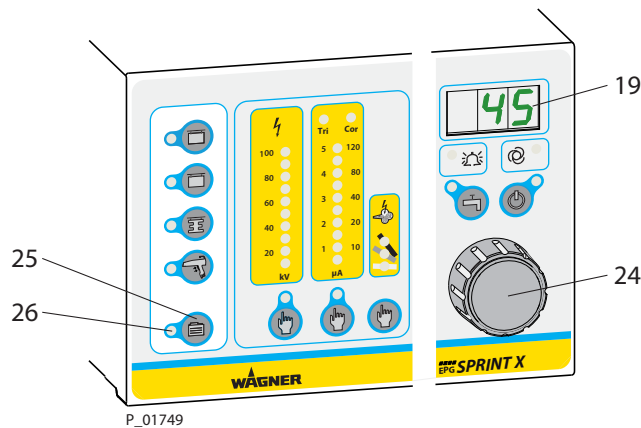
7.6.2 RECIPE NO. 5-50

P_01749

Recipes 5-50 can be indirectly selected and saved. First press the "Additional Recipes" button 25. The yellow "Additional Recipes" LED 26 then lights up and the LED display 19 indicates the current recipe number. The required recipe can be set by turning the universal rotary controller 24. In the following example, the values in recipe no. 10 are to be modified and saved.

Procedure:

1. Select recipe no. 10.
2. Set the desired values in the recipe (see Chapters 7.7.1-7.7.8).
3. Instead of showing the current recipe number, the LED display 19 now shows the modified value.
4. To save the changes, hold down the "Additional Recipes" button 25 until the previous recipe number flashes in the LED display 19.
5. To save the values, there are two options:
 - To save the recipe to the recipe number currently displayed, hold the "Additional Recipes" button 25 down for another 2 seconds until the yellow "Additional Recipes" LED 26 flashes quickly. The modified values are then saved to the original recipe.
 - To save the changes to another recipe number, use universal rotary controller 24 to set the desired recipe number - this is now displayed flashing. To save the values, press and hold down the "Additional Recipes" button 25 for 2 seconds until the yellow "Additional Recipes" LED 26 flashes quickly. The changes are thereby saved to the set recipe number.

7.7 SETTING AND CHANGING COATING PARAMETERS

7.7.1 SETTING THE TOTAL AIR VOLUME

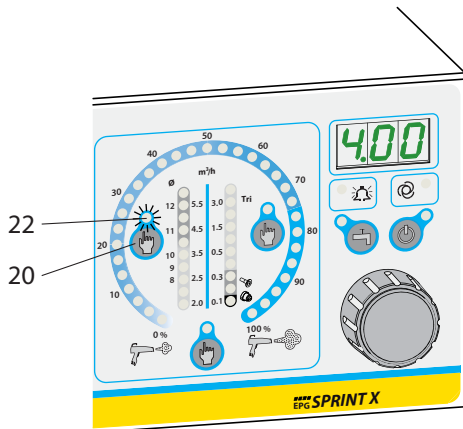

Procedure:

1. Press "Total Air Volume" button 20 to adjust the total air volume. Yellow LED 22 indicates that the total air volume is selected.

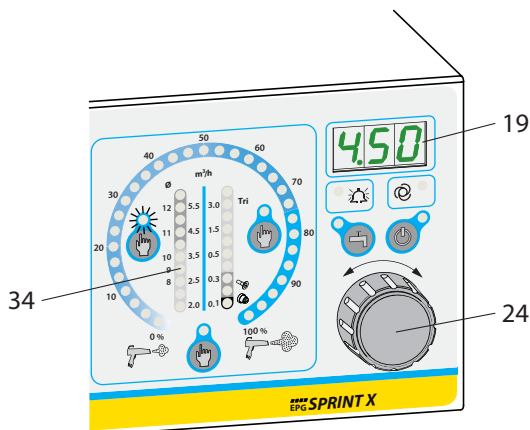

2. The total air volume can now be adjusted using the universal rotary controller 24 between 1-6 m³/h with a resolution of 0.05 m³/h. The value is shown in the LED display 19.

P_01751

To the right of the "Total Air Volume" button 20 is the "Total Air" bar graph display 34. When the control unit is in the ready position, this light strip shows the set point as a dot and when powder feeding is switched on it shows the actual value as a bar.

To the right of the bar graph is the scale for the total air volume. To the left of the bar graph is another scale indicating the hose diameter. This scale shows the correlation between the total air volume and the inner hose diameter (see operating manuals for the powder injectors PI-F1 and HiCoat ED-Pump-F). The inner hose diameter is printed on the powder hose.

Example:

Inner hose diameter 11 mm

Total air 4.5 m³/h

The total air volume can be adjusted between 1-6 m³/h as described above. If this value is further reduced from a value of 1 m³/h, the word "off" appears in the LED display 19 to signal that the total air supply is deactivated. The total air supply is not therefore activated when the powder feed is switched on.

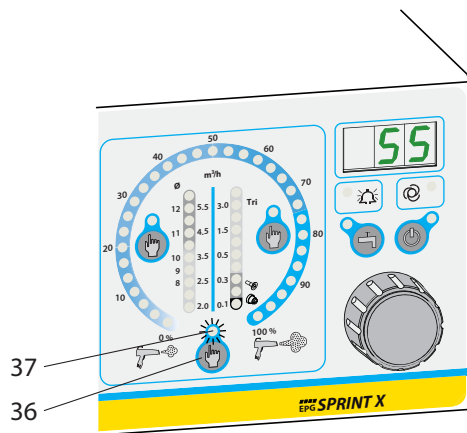
7.7.2 SETTING THE POWDER FEED QUANTITY**Procedure:**

1. Press "Powder Quantity" button 36 to adjust the powder quantity. Yellow LED 37 indicates that the powder quantity is selected.

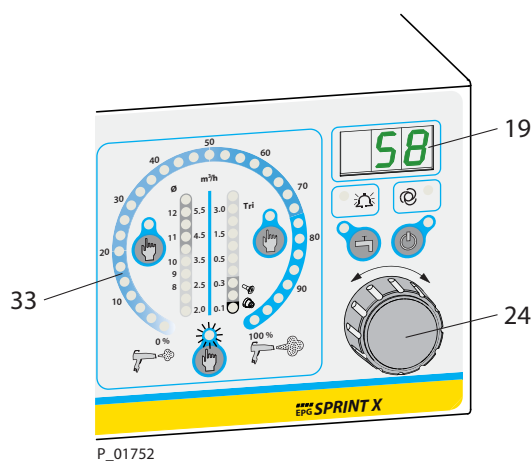

2. The powder quantity can now be adjusted using the universal rotary controller 24 between 0% - 100% with a resolution of 1%. The value is shown in the LED display 19.

When the control unit is in the ready position, the circular light strip 33 shows the set point as a dot and, when powder feed is switched on, it shows the actual value as a bar. The powder quantity setting as % refers to the percentage distribution between the different air types.

Example:

75% powder quantity means that 75% of the total air volume is supplied to the feed air and 25% to the dosing air. The greater the proportion of feed air, the greater the powder quantity for the specified total air volume.

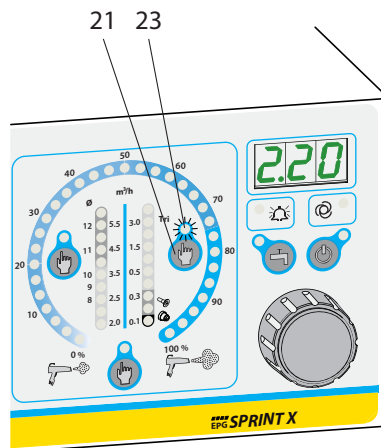
7.7.3 SETTING THE ADDITIONAL AIR (ATOMIZING/IONIZING/TRIBO AIR VOLUME)**Procedure:**

1. Press "Additional Air" button 21 to set the additional air volume. Yellow LED 23 indicates that the additional air is selected.

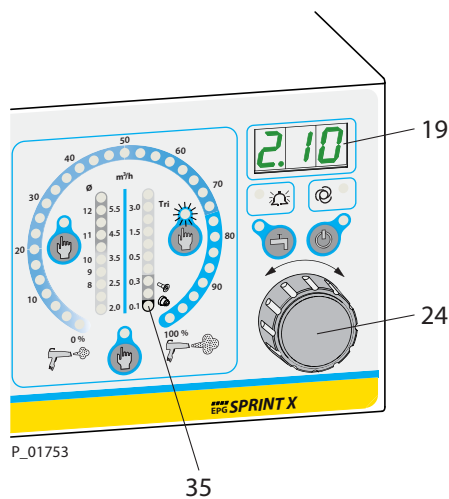

2. The additional air volume can now be adjusted using the universal rotary controller 24 between 0.05-4.0 m³/h with a resolution of 0.05 m³/h. The value is shown in the LED display 19.

The "Additional Air" bar graph display 35 can be found to the left of the "Additional Air" button 21. When the control unit is in the ready position, this light strip shows the set point as a dot and when powder feeding is switched on it shows the actual value as a bar.

Different amounts of air are required depending on the type or gun and/or nozzle. For the correct settings, please refer to the operating manual for the relevant powder spray gun.

The additional air volume can be set to 0.05 - 4 m³/h as described above.

The additional air cannot be fully deactivated, therefore the spray gun always receives minimal additional air.

7.7.4 SETTING THE HIGH-VOLTAGE

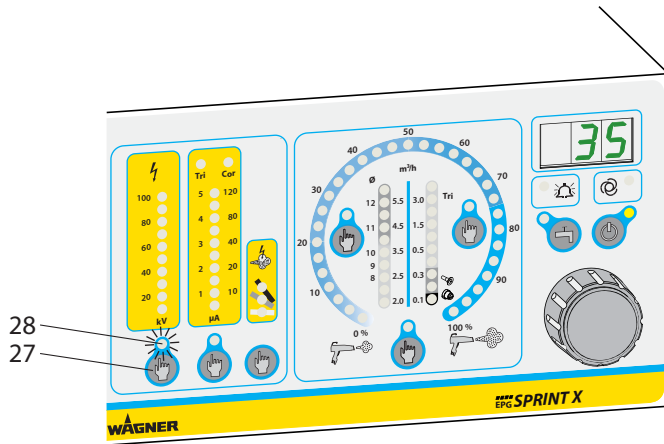

Procedure:

1. Press the "High-voltage" button 27 to adjust the high-voltage. The yellow LED 28 indicates that high-voltage is selected.

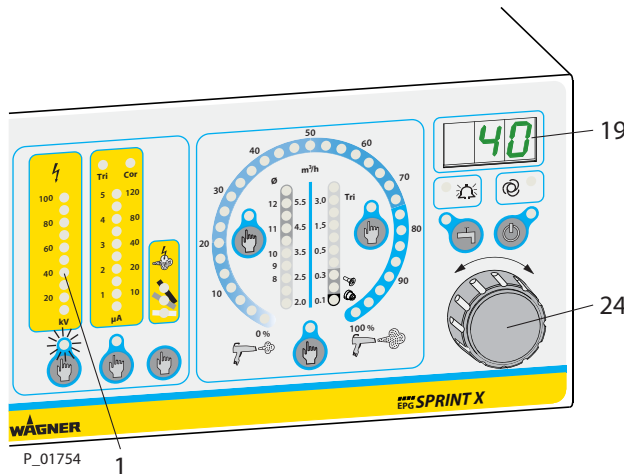

2. The high-voltage can now be adjusted using the universal rotary controller 24 between 10 kV - 100 kV with a resolution of 1 kV. The value is shown in the LED display 19.

Above the "High-voltage" button 27 is the "High-voltage" bar graph display 1. When the control unit is in the ready position, this display shows the set point as a dot and, when high-voltage is switched on, it shows the actual value as a bar. The high-voltage can be adjusted between 10-100 kV as described above. If this value is further reduced from a value of 10 kV, the word "off" appears in the LED display 19 to signal that the high-voltage is deactivated. The high-voltage generation is not therefore activated when the powder feed is switched on.

7.7.5 DISPLAY OF ACTUAL HIGH-VOLTAGE VALUE

The actual high-voltage value can be displayed during the coating process in LED display 19.

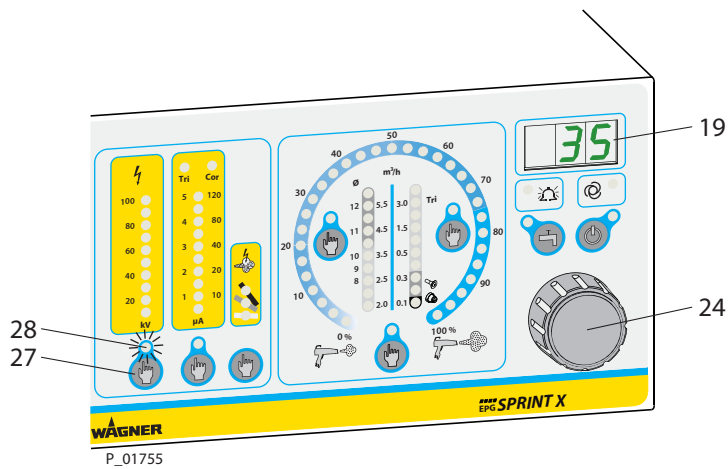
**Procedure:**

1. Press "High-voltage" button 27 for around 2 seconds. Yellow LED 28 flashes quickly.

The actual high-voltage value is shown in the LED display 19 for 5 seconds, the display returns to the previous display after this time.

The actual value display can be interrupted also before expiration of the 5 seconds by pressing a selection button or turning rotary controller.

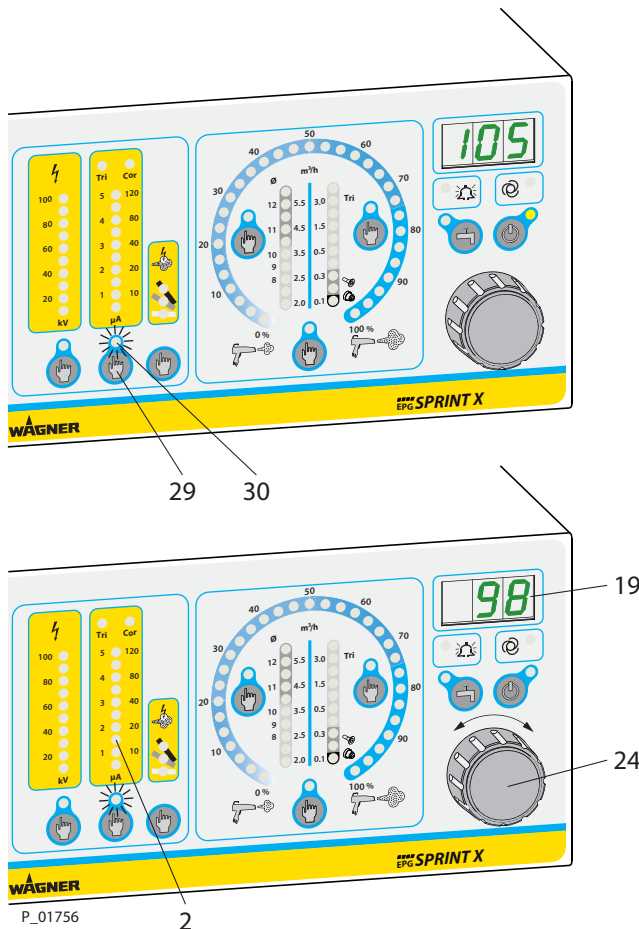
7.7.6 SETTING THE CURRENT LIMITATION**Procedure:**

1. Press the "Current Limitation" button 29 to adjust the limitation of the spray current. The yellow LED 30 indicates that current limitation is selected.
2. The current limitation can now be adjusted using the universal rotary controller 24 between 5-120 μA with a resolution of 1 μA . The value is shown in the LED display 19.

Above the "Current Limitation" button 29 is the "Current Limitation" bar graph display 2. When the control unit is in the ready position, this display shows the set point as a dot and, when high-voltage is switched on, it shows the actual value as a bar. The current limitation is an adjustable threshold. If this threshold is exceeded, the high-voltage is adjusted downwards until the threshold is no longer exceeded.

7.7.7 DISPLAYING ACTUAL VALUE OF CURRENT LIMITATION

The actual current limitation value can be displayed in LED display 19 during the coating process.

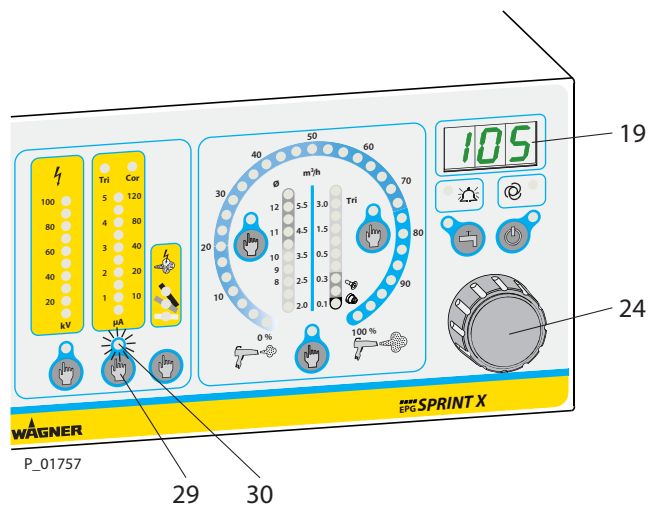
**Procedure:**

1. Press the "Current Limitation" pushbutton 29 approx. 2 seconds. Yellow LED 30 flashes quickly.

The actual current limitation value is shown in the LED display 19 for 5 seconds, the display returns to the previous display after this time.

The actual value display can be interrupted also before expiration of the 5 seconds by pressing a selection button or turning rotary controller.

7.7.8 SETTING THE U/I CHARACTERISTICS

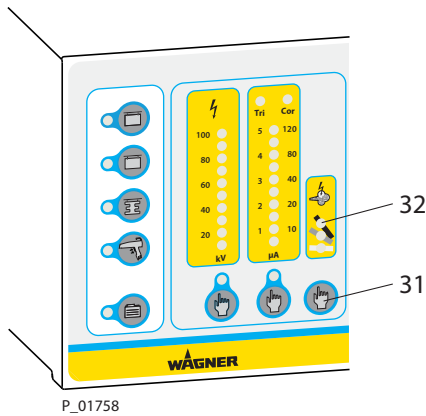

Procedure:

To change the characteristic slope, press the "Characteristic Slope" button 31 once or twice until the desired characteristic curve is shown in the "Characteristic Slope" LED display 32.

U/I characteristics for EPG-SPRINT X

The user can choose from three characteristic curves to achieve optimum coating results. These enable optimum electrostatic charging of the powder despite different powder characteristics.

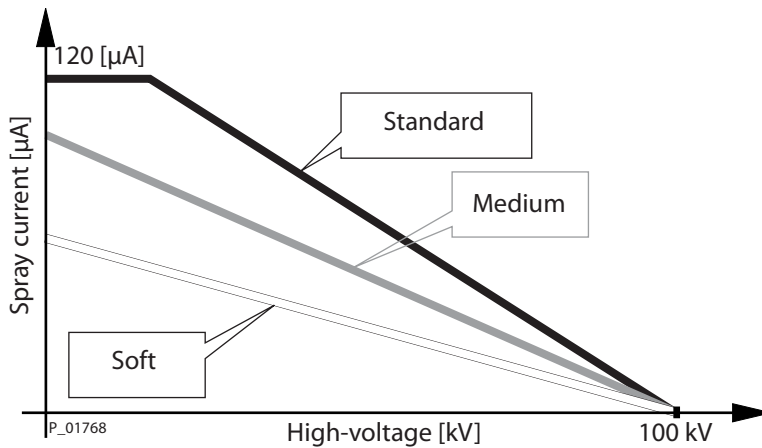

The properties of the various characteristic curves and their use are described on the following page.

Properties of the characteristic curve	Field of application/remarks
Standard level (black) <ul style="list-style-type: none"> ● Open-circuit voltage 100 kV ● Maximum current 120 μA (Current limitation at 120 μA) 	<ul style="list-style-type: none"> ● for poorly rechargeable types of powder ● for high powder application ● for high application effectiveness ● This setting corresponds to the usual Wagner high-voltage modules and control units.
Medium level (gray) <ul style="list-style-type: none"> ● Open-circuit voltage 100 kV ● Maximum current 120 μA 	<ul style="list-style-type: none"> ● for small surfaces ● for types of powder that recharge well ● for metallic powder ● to reduce the effects of overcoating such as craters and orange peel ● Increasing the open-circuit voltage allows for a greater distance between the spray gun and the work piece while maintaining sufficient powder charging.
Soft level (white) <ul style="list-style-type: none"> ● Open-circuit voltage 100 kV ● Maximum current 80 μA 	<ul style="list-style-type: none"> ● for types of powder that recharge well ● for small powder application ● for post-coatings

7.8 PURGE FUNCTION

The EPG-SPRINT X control unit has two different purge functions:

- Hose purge function
- Cleaning purge function

7.8.1 HOSE PURGE FUNCTION

This function blows dosing air through the powder feed hose and spray guns when the powder flow is switched off (manual guns - releasing of trigger lever, automatic guns-signal from control).

This function is set to the "OFF" parameter value in the factory. The values can be changed in the parameter settings for parameters C22 and C23 (see Device Configuration chapter).

7.8.2 CLEANING PURGE FUNCTION

This function is used at the end of a shift or during a change in color. All parts carrying powder are purged. The purge process is as described below:

First the atomizing air is activated. After around 0.5 seconds, the feed and dosing air are added, increasing all the time. After a total of 2.5 seconds, the feed and dosing air purge in pulses while the atomizing air remains constant throughout.

The cleaning purge function is only available when the control unit is switched on and in the operating mode. In standby mode or in configuration mode, this function is inactive.

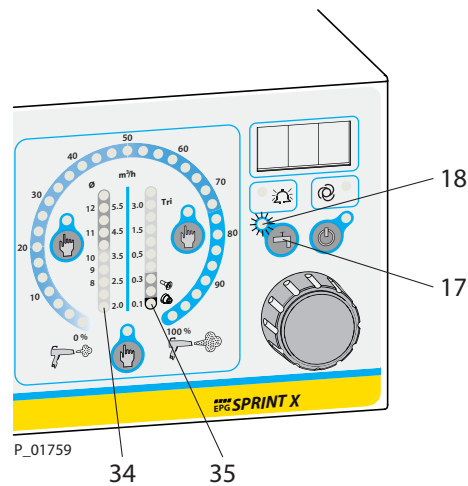
7.8.3 PROCEDURE FOR CLEANING PURGING WITH MANUAL GUNS**Procedure:**

1. End coating operation.
2. Remove powder suction unit (suction lance, powder injector) from powder tank.
3. Switch on purge function by pressing "Purge" button 17 on the control unit.
LED display 18 lights up permanently.
Close function by again pressing "Purge" button 17.

The activated function is also indicated by the "Overall Air" indicator 34 and "Atomizer/Ionizer/Tribo Air" indicator 35 lighting up.

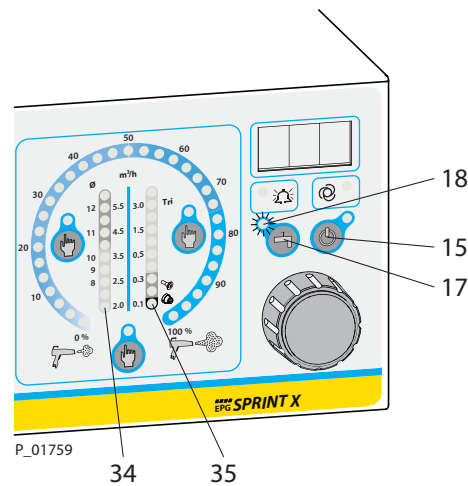
7.8.4 PROCEDURE FOR CLEANING PURGING WITH AUTOMATIC GUNS**Procedure:**

1. End coating operation.
2. Remove powder suction unit (suction lance, powder injector) from powder tank.
3. Switch on purge function by pressing "Purge" button 17 on the control unit.
LED display 18 starts to flash and indicates readiness for purging.
4. Process should be repeated for each spray gun that is to be purged.
If you do not want a purging process, press "Standby" button 15.
5. Start purge process using "Gun Start" on unit's control.
6. Stop purge process using "Gun Stop" on unit's control.
7. Re-activate control units in standby mode by pressing the "Standby" button 15.
8. Press "Purge" button 17 to return to normal coating mode.
The LED display 18 no longer flashes.
9. Once the suction lance has been lowered into the powder tank, the coating operation can be continued again.

Note:

If configuration parameter C16 is set to "ON", the purge function can only be activated via the serial interface.

7.9 STARTING OUTPUT SETTING (ZERO ADJUSTMENT)

This function can be used to set the point from which powder is fed.
The starting output setting is subject to:

- The diameter of the powder hose
- The length of the powder hose
- The feed properties of the powder

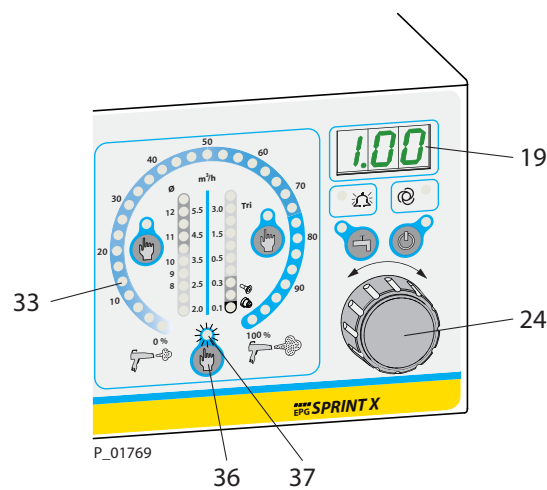

Procedure: (if no powder is fed at 0%)

1. Press "Powder Quantity" button 36 for around 2 seconds. The "Powder Quantity" LED 37 flashes rapidly, the powder quantity display 33 flashes. The current value is shown in the LED display 19 (e.g., 1.00 means a factory setting of 0.00 Nm³/h).
2. Turn rotary controller 24 until just a small amount of powder is fed.
3. To save, hold down the "Powder Quantity" button 36, LED display 19 flashes. To discard the set value, press any button briefly. The value that was originally set is reloaded.

Note:

The starting output value is set to 0.00 at the factory.

If the set value is changed, the coating parameters also change, as altering the value alters the feed air (see diagram).

Example: Total air = 4.00 Nm³/h

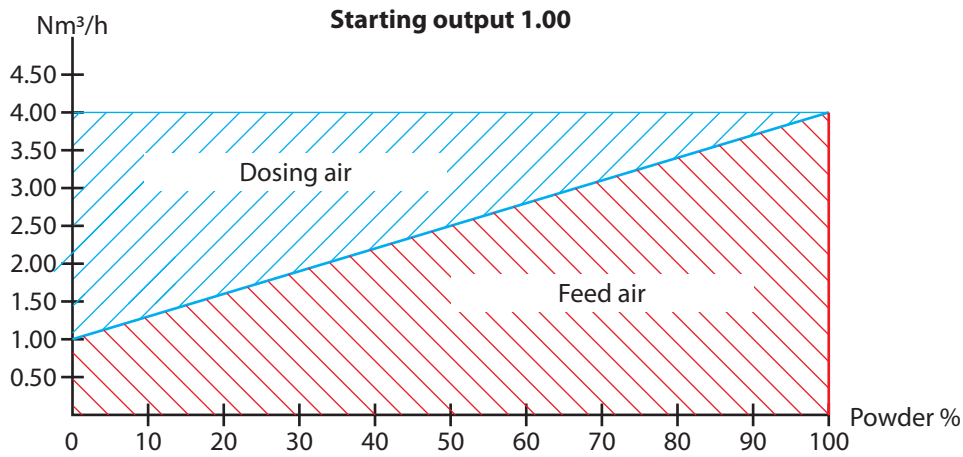
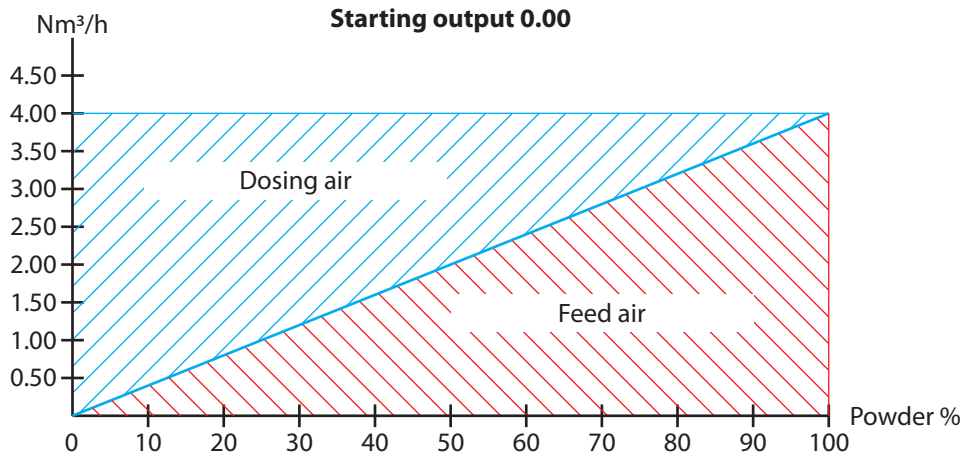

P_02368

8 CLEANING AND MAINTENANCE

8.1 CLEANING



8.1.1 CLEANING STAFF



Cleaning work should be undertaken regularly and carefully by qualified and trained staff. They should be informed of specific hazards during their training.

The following hazards may arise during cleaning work:

- Health hazard from inhaling powder lacquer
- Use of unsuitable cleaning tools and aids

8.1.2 SAFETY INSTRUCTIONS

	 <b style="font-size: 1.2em;">DANGER
<p>Explosive powder/air mixes! Danger to life and damage to the device.</p> <ul style="list-style-type: none"> → Before starting cleaning or other manual work, the high-voltage must be shut down and locked to prevent it from being switched back on! → The spray gun must be separated from the high-voltage supply before any cleaning work is started! → Use only electrically conductive tanks for cleaning liquids. Ground the tank. → Preference should be given to non-flammable cleaning fluids. → Flammable cleaning liquids may only be used if, after switching off the high-voltage, all high-voltage conducting parts are discharged to a discharge energy of less than 0.24 mJ before they can be accessed. Most flammable solvents have an ignition energy of around 0.24 mJ or 60 nC. → The cleaning agent's flash point must be at least 15 K above the ambient temperature. → Only mobile industrial vacuum cleaners of design 1 (see EN 60335-2) may be used to remove dust deposits. 	

	 WARNING
	<p>Incorrect maintenance! Risk of injury and damage to the device.</p> <ul style="list-style-type: none">→ If contact with powder products or cleaning agents causes skin irritation, appropriate precautionary measures must be taken, e.g., wearing protective clothing.→ The footwear worn by operating staff must comply with EN ISO 20344. The measured insulation resistance must not exceed 100 megohms.→ The protective clothing, including gloves, must comply with EN ISO 1149-5. The measured insulation resistance must not exceed 100 megohms.

8.1.3 CLEANING PROCEDURES

The cleaning intervals should be adapted by the operator depending on the level of use and if necessary the level of soiling.

If in doubt, we recommend contacting J. Wagner AG's specialist personnel.

The valid health and safety specifications and the safety instructions provided in Chapter 4 must be adhered to for all cleaning work.

8.2 MAINTENANCE

8.2.1 MAINTENANCE STAFF



Maintenance work should be undertaken regularly and carefully by qualified and trained staff. They should be informed of specific hazards during their training.



The following hazards may arise during maintenance work:

- Health hazard from inhaling powder lacquer
- Use of unsuitable tools and aids

Once the maintenance work is complete, the device must be checked by a qualified person to ensure a reliable condition.

8.2.2 SAFETY INSTRUCTIONS

	 DANGER
	<p>Incorrect maintenance/repair! Danger to life and damage to the device.</p> <p>→ Repair or replacement of devices or parts of devices are only allowed to be performed outside the hazard area by qualified personnel.</p>

	 DANGER
	<p>Incorrect maintenance/repair! Risk of injury and damage to the device.</p> <p>→ Have repairs and part replacements carried out only by specially trained staff or a WAGNER service center.</p> <p>→ Before all work on the device and in the event of work interruptions:</p> <ul style="list-style-type: none"> - Switch off the energy/compressed air supply. - Relieve spray gun and device pressure. - Secure the spray gun against actuation. <p>→ Observe the operating manual and service manuals at all times when carrying out work.</p>

	WARNING
	<p>Incorrect maintenance! Risk of injury and damage to the device.</p> <ul style="list-style-type: none"> → If contact with powder products or cleaning agents causes skin irritation, appropriate precautionary measures must be taken, e.g., wearing protective clothing. → The footwear worn by operating staff must comply with EN ISO 20344. The measured insulation resistance must not exceed 100 megohms. → The protective clothing, including gloves, must comply with EN ISO 1149-5. The measured insulation resistance must not exceed 100 megohms.

8.2.3 MAINTENANCE PROCEDURES

The maintenance intervals should be adapted by the operator depending on the level of use and if necessary the level of soiling.

If in doubt, we recommend contacting J. Wagner AG's specialist personnel.

The valid health and safety specifications and safety instructions provided in Chapter 4 must be adhered to for all maintenance work.

Maintenance work	Point in time	
	per shift	weekly
Blow out gun and check for sintering	x	
Check gun settings	x	
Check gun discharge pressure	x	
Blow out powder hoses	x	
Check grounding		x
Check compressed air quality		x
Check gun voltage		x
Check powder hoses for bends and sintering		x

9 INSPECTIONS

9.1 INSPECTIONS IN ACCORDANCE WITH DIN EN 50177: 2010

If the control unit is used in a stationary system for electrostatic coating with flammable coating powders, testing should be undertaken in accordance with DIN EN 50177: 2010-04 as per Table 3 and Table 4.

OPERATING MANUAL



Section	Type of inspection	Requirements	Inspection by	Type of inspection	Inspection interval
1	Effectiveness of technical ventilation check	Effectiveness of technical ventilation check	TP/CP	ME Measurements of air flow speed / air quantities Check the differential pressure indicator.	continuously
2	Interlock between technical ventilation and high-voltage, compressed air and coating product supply	The technical ventilation should be interlocked so that the powder feed and high-voltage cannot be switched on while the technical ventilation is not working effectively.	CP	FI Test whether the system is safely stopped and the product supply, supply air, and high-voltage are switched off when the ventilation is shut down.	annually
3	Parts carrying high-voltage outside the spray area	Parts carrying high-voltage outside the spray area must be routed such that discharges which put people at risk do not occur.	CP	FI Inspect and test (e.g., by measurement) whether all parts carrying high-voltage do not result in discharge which puts people at risk.	weekly

Legend:
 MA = Manufacturer
 EM = Employer
 SP = Skilled person
 FSE = Fire safety engineer
 ELC = Electrician
 TP = Trained person

FI = Function inspection
 ME = Measurement
 SI = Standard inspection
 VI = Visual inspection
 CI = Continuous inspection
 TI = Technical inspection



Section	Type of inspection	Requirements	Inspection by	Type of inspection	Inspection interval
4	Effectiveness of grounding measures	All the system's conductive elements, such as floors, walls, ceilings, protective grating, transport equipment, work pieces, powder tanks, machines or construction parts etc. in the spray area, with the exception of parts which carry high-voltage during operation, must be connected to the grounding system. Parts of the booth must be grounded in accordance with EN 12215.	CP	VI/ME/CI Visual check of ground connections, perform function test on grounding switch, measurement of grounding resistors.	weekly
5	Measures to take if conductive components are insufficiently grounded	If sufficient grounding of conductive parts cannot be ensured, their discharge energy must not exceed the permissible value.	CP	ME/CI Measurement of discharge energy.	weekly
6	Resistance to ground of work piece's locating point	The resistance to ground of every work piece's locating point must not exceed 1 megohm (measurement voltage must be 1,000 V). The design of the work piece receiver must ensure that the adapters remain grounded during coating.	CP	ME/CI Measure resistance to ground (work piece receiver - ground potential) max. 1 megohm @ 1,000 V.	weekly

Legend:
 MA = Manufacturer
 EM = Employer
 SP = Skilled person
 FSE = Fire safety engineer
 ELC = Electrician
 TP = Trained person

FI = Function inspection
 ME = Measurement
 SI = Standard inspection
 VI = Visual inspection
 CI = Continuous inspection
 TI = Technical inspection

OPERATING MANUAL



Section	Type of inspection	Requirements	Inspection by	Type of inspection	Inspection interval
7	Measures to take if the work pieces are insufficiently grounded	If sufficient work piece grounding in accordance with section 6 cannot be ensured, appropriate equipment, e.g., ionizers, must be used to discharge electric charges on the work piece. Such equipment must not exceed the permitted discharge energy of the spray systems with which it is used. In terms of permitted discharge energy, this equipment must be put through the same inspections as the powder spray systems used with it. The discharge equipment must be interlocked with the spray system such that the high-voltage is switched off and that coating cannot take place if the discharge equipment malfunctions.	CP	ME/FU/SÜ Measurement of discharge energy, check the monitoring equipment's test function by triggering it.	weekly
8	Effectiveness of the manually or automatically actuated fire extinguishing systems (room protection system)	Effectiveness of the manually or automatically actuated fire extinguishing systems (room protection system).	HE/BSB	FI Trigger fire extinguishing system, observe manufacturer's requirements.	6 months

Legend:
 MA = Manufacturer
 EM = Employer
 SP = Skilled person
 FSE = Fire safety engineer
 ELC = Electrician
 TP = Trained person

FI = Function inspection
 ME = Measurement
 SI = Standard inspection
 VI = Visual inspection
 CI = Continuous inspection
 TI = Technical inspection

9.2 INSPECTIONS IN ACCORDANCE WITH DIN EN 50050-2: 2014

If the control unit is used in a manual spray system for electrostatic coating with flammable coating powders, testing should be undertaken in accordance with DIN EN 50050-2: 2014-03 as per Table 1.

OPERATING MANUAL



Section	Type of inspection	Requirements	Inspection by	Type of inspection	Inspection interval
1	Resistance to ground of work piece's locating point	The resistance to ground of every work piece's locating point must not exceed 1 megohm (measurement voltage must be 1,000 V). The design of the work piece receiver must ensure that the adapters remain grounded during coating.	CP	ME/CI Measure resistance to ground (work piece receiver - ground potential) max. 1 megohm @ 1,000 V.	weekly
2	Interlock between technical ventilation and high-voltage, compressed air and coating product supply	The technical ventilation should be interlocked such that the high-voltage cannot be switched on while the technical ventilation is not working effectively.	CP	FI Test whether the system is safely stopped and the product supply, supply air, and high-voltage are switched off when the ventilation is shut down.	annually
3	Inspection of the electrostatic manual spray equipment for damage	Electrostatic manual spray equipment may only be operated in an intact condition, damaged devices must be decommissioned immediately and repaired.	CP	FI Inspect and test (e.g., by measurement) whether all parts carrying high-voltage do not result in discharge which puts people at risk.	weekly



Legend:

- MA = Manufacturer
- EM = Employer
- SP = Skilled person
- FSE = Fire safety engineer
- ELC = Electrician
- TP = Trained person

- FI = Function inspection
- ME = Measurement
- SI = Standard inspection
- VI = Visual inspection
- CI = Continuous inspection
- TI = Technical inspection

10 DISASSEMBLY AND DISPOSAL

10.1 DISASSEMBLY

	 WARNING
	<p>Incorrect disassembly! Risk of injury and damage to the device.</p> <p>→ Before starting disassembly:</p> <ul style="list-style-type: none">- Switch off the energy/compressed air supply.- Ensure that all system components are grounded.- Secure system against being switched back on without authorization. <p>→ Observe the operating manuals for any work.</p>

Procedure:

1. Switching off the system.
2. Lock the compressed air supply and decompress system.
3. Release electrical cable on control unit.
4. Detach hose for compressed air supply on control unit.
5. Detach hoses for the feed air, dosing air and atomizing air on the control unit.
6. Remove grounding cable on control unit.
7. Loosen retaining nuts and dismount control unit.

10.2 DISPOSAL

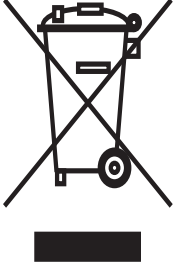
	<p style="text-align: center;">NOTICE</p> <p>Do not dispose of used electrical equipment with household refuse!</p> <p>In accordance with European Directive 2002/96/EC on the disposal of used electrical equipment and its implementation in national law, this product may not be disposed of with the household refuse, but must be recycled in an environmentally correct manner. Wagner or one of our dealers will take back your used Wagner waste electrical or electronic equipment and will dispose of it for you in an environmentally friendly way. Please contact one of our service points, one of our representatives or us directly to arrange this.</p>
---	--

11 TROUBLESHOOTING AND RECTIFICATION



DANGER

Incorrect maintenance/repair!

Risk of injury and damage to the device.

- Have repairs and part replacements carried out only by specially trained staff or a WAGNER service center.
- Before all work on the device and in the event of work interruptions:
 - Switch off the energy/compressed air supply.
 - Relieve spray gun and device pressure.
 - Secure the spray gun against actuation.
- Observe the operating manual and service manuals at all times when carrying out work.



DANGER

Incorrect maintenance/repair!

Danger to life and damage to the device.

- Wagner devices, protective systems and safety, monitoring and control equipment may only be repaired as defined in Directive 94/9/EC (ATEX) by trained Wagner service personnel or capable persons in accordance with TRBS 1203! Note national regulations!
- Repair or replacement of devices or parts of devices may only be performed outside the hazard area!

11.1 WARNINGS E01-E04

The fault LED 13 flashes to indicate warnings. In addition "Exx" is shown alternately in the LED display 19 (7-segment LED) (xx stands for the warning number). Work can continue if a warning is displayed.

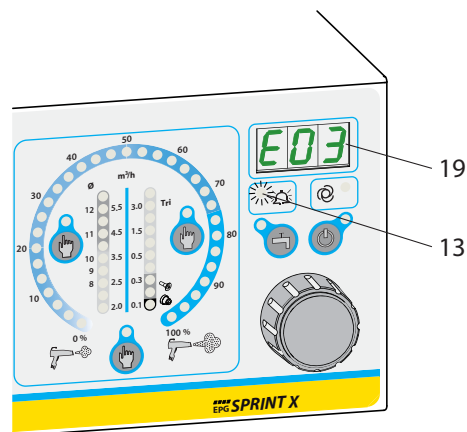

P_01760

Warning No.	Warning	Cause	Remedy
E01	Atomizing air too low	Set point cannot be reached Causes: <ul style="list-style-type: none"> ● Hose kinked / blocked ● Input air pressure too low ● System cannot reach target setting 	<ul style="list-style-type: none"> ● Check hoses and hose laying ● Ensure that input pressure is greater than 6 bar ● Check gun and nozzle system
E02	Dosing air too low	Set point cannot be reached Causes: <ul style="list-style-type: none"> ● Hose kinked / blocked ● Input air pressure too low ● Injector is not connected ● System cannot reach target setting 	<ul style="list-style-type: none"> ● Check hoses and hose laying ● Ensure that input pressure is greater than 6 bar ● Connect injector correctly ● Check hoses and hose laying
E03	Feed air too low	Set point cannot be reached Causes: <ul style="list-style-type: none"> ● Hose kinked / blocked ● Input air pressure too low ● Injector is not connected ● System cannot reach target setting 	<ul style="list-style-type: none"> ● Check hoses and hose laying ● Ensure that input pressure is greater than 6 bar ● Connect injector correctly ● Select smaller set point value Example: Feed air for ED pump max. 3.5 Nm³/h
E04	Fallen below Tribo current limit for 10 s	The Tribo current set in the configuration cannot be reached Causes: <ul style="list-style-type: none"> ● Tribo air set too low ● Powder not flowing due to incorrect settings for feed air and total air ● No powder in tank ● The powder does not have the required charging characteristics 	<ul style="list-style-type: none"> ● Increase Tribo air ● Correct feed air and total air settings ● Fill powder tank ● Use suitable powder

11.2 FAULTS

Faults are indicated by fault LED 13 lighting up. In addition, the error number "Exx" (xx stands for the fault number) is shown in the LED display 19 (7-segment LED). If a fault occurs, high-voltage, air, etc. is immediately switched off. Work can be continued only after removing the fault and pressing any button.

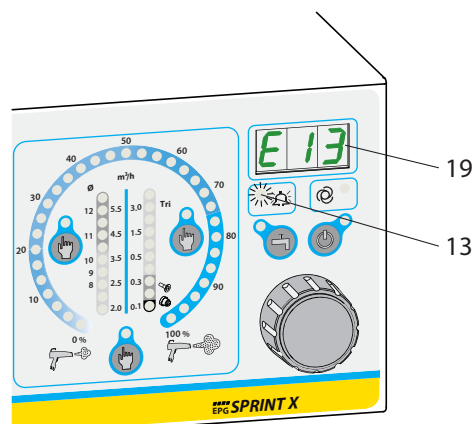

P_01761

Fault number	Fault	Cause	Remedy
E11	Ground monitoring	<ul style="list-style-type: none"> ● Grounding cable is interrupted ● Gun is not connected 	<ul style="list-style-type: none"> ● Check/replace gun cable ● Check/replace gun ● Connect gun
E12	No coil current/ cascade interrupt	<ul style="list-style-type: none"> ● Gun is not connected ● Gun cable is interrupted ● Cascade in gun is interrupted --> defective 	<ul style="list-style-type: none"> ● Connect gun ● Check/replace gun cable ● Check/replace gun
E13	Coil current too big	<ul style="list-style-type: none"> ● Cascade of the connected gun is defective 	<ul style="list-style-type: none"> ● Check/replace gun
E14	Tribo current too high	<ul style="list-style-type: none"> ● The Tribo current has exceeded the upper limit value of 12 µA ATEX guidelines do not permit higher values. 	<ul style="list-style-type: none"> ● Reduce Tribo air ● Reduce powder quantity

Fault number	Fault	Cause	Remedy
E15-E17	High-voltage generator error	<ul style="list-style-type: none"> ● Hardware defect 	<ul style="list-style-type: none"> ● If problem persists, contact Wagner Service Team ● Switch off unit and after 10 seconds, switch on again
E18	Result of corona measurement is implausible	<ul style="list-style-type: none"> ● Hardware defect 	<ul style="list-style-type: none"> ● If problem persists, contact Wagner Service Team
E20	Password error	<ul style="list-style-type: none"> ● The password for enabling the device is not set or has been lost 	<ul style="list-style-type: none"> ● Inform Wagner service center
E21-E25	Exception error	<ul style="list-style-type: none"> ● Hardware defect has occurred 	<ul style="list-style-type: none"> ● If problem persists, contact Wagner Service Team
E31	Gun switch monitoring in automatic mode	<ul style="list-style-type: none"> ● The gun switch line has been interrupted ● Gun unplugged during operation 	<ul style="list-style-type: none"> ● Check gun cable ● Check gun
E41	No flow of atomizing air	<p>No air is flowing out of the control unit</p> <p>Causes:</p> <ul style="list-style-type: none"> ● Hose kinked / blocked ● Gun blocked ● Compressed air switched off 	<p>Check:</p> <ul style="list-style-type: none"> ● The hose laying ● The air supply to the control unit ● Input pressure > 6 bar ● Open compressed air
E42	No flow of dosing air	<p>No air is flowing out of the control unit</p> <p>Causes:</p> <ul style="list-style-type: none"> ● Hose kinked / blocked ● Injector is not connected ● Compressed air switched off 	<p>Check:</p> <ul style="list-style-type: none"> ● The hose laying ● The air supply to the control unit ● Input pressure > 6 bar ● Connect injector ● Open compressed air

Fault number	Fault	Cause	Remedy
E43	No flow of feed air	No air is flowing out of the control unit Causes: <ul style="list-style-type: none"> ● Hose kinked / blocked ● Injector is not connected ● Compressed air switched off 	Gun unplugged during operation Check: <ul style="list-style-type: none"> ● The hose laying ● The air supply to the control unit ● Input pressure > 6 bar ● Connect injector ● Open compressed air
E51-E53	Exception error	<ul style="list-style-type: none"> ● Hardware defect has occurred 	<ul style="list-style-type: none"> ● If problem persists, contact Wagner Service Team
E54	Hardware error	<ul style="list-style-type: none"> ● Hardware defect has occurred ● Atomizing air duct valve leaking 	<ul style="list-style-type: none"> ● Detach hose on rear of valve and in standby mode, check the valve for seal integrity (air supply must be connected)
E55	Hardware error	<ul style="list-style-type: none"> ● Hardware defect has occurred ● Dosing air duct valve leaking 	<ul style="list-style-type: none"> ● Detach hose on rear of valve and in standby mode, check the valve for seal integrity (air supply must be connected)
E56	Hardware error	<ul style="list-style-type: none"> ● Hardware defect has occurred ● Feed air duct valve leaking 	<ul style="list-style-type: none"> ● Detach hose on rear of valve and in standby mode, check the valve for seal integrity (air supply must be connected)
E60	Operation without external release (only for manual gun with external control)	<ul style="list-style-type: none"> ● No release from ● Missing or defective wiring 	<ul style="list-style-type: none"> ● Check external control

12 ACCESSORIES

12.1 CONNECTION CABLES

Order No.	Designation
241270	Mains cable Europe
241271	Mains cable Switzerland
264626	Mains cable USA
264625	Mains cable Japan
130215	Grounding cable, 10 m; 32.8 ft
263219	Grounding cable Japan
9990149	Y-piece

12.2 WALL MOUNT

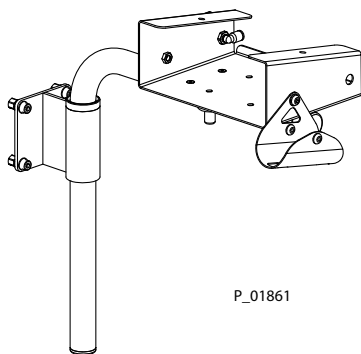

Order No.	Designation
2330223	Wall mount with bracket

12.3 RECIPE STICKER

The recipe sticker layout includes the following elements:

- Top Row:** Four icons representing different parameters: Voltage (kV), Tribo Corona (µA), [Nm²/h], and [Nm²/h].
- Parameter Grid:**

[kV]	90	80	4.0	70
[µA]	50	20	3.6	57
[Nm ² /h]	70	40	3.6	50
[Nm ² /h]	82	20	3.6	45
- Right Column:**
 - [Nm²/h] 0.1
 - [Nm²/h] > 0.2
 - [Nm²/h] (with warning icon)
 - [Nm²/h] (with spray gun icon)
- Bottom Table:**

[name]	80	100	4.5	80
P5				
P6				
P7				
P8				
P9				
P10				
- Footer:** WAGNER logo, copyright symbol, email symbol, and website www.wagner-group.com/industry.

P_01829

Order No.	Designation
2331223	Recipe sticker

13 SPARE PARTS

13.1 HOW CAN SPARE PARTS BE ORDERED?

To ensure proper spare parts delivery, the following information is necessary:

Order number, designation, and quantity

The quantity need not be the same as the number given in the quantity column "Stk" on the lists. This number merely indicates how many of the respective parts are used in each component.



The following information is also required to ensure smooth processing of your order:

- Billing address
- Delivery address
- Name of the person to be contacted in the event of any queries
- Type of delivery (normal mail, express delivery, air freight, courier etc.)

Identification in spare parts lists

Explanation of column "K" (labeling) in the following spare parts lists.

- ◆ = Wearing parts
Note: These parts are not covered by warranty terms
- = Not part of the standard equipment but available as a special accessory.

	 WARNING
	<p>Incorrect maintenance/repair! Risk of injury and damage to the device.</p> <p>→ Repairs and part replacement may only be carried out by specially trained staff or a WAGNER service center.</p> <p>→ Before all work on the device and in the event of work interruptions:</p> <ul style="list-style-type: none"> - Switch off the energy/compressed air supply. - Ensure that all system components are grounded. - Secure the device against being switched back on without authorization. <p>→ Observe the operating and service manual at all times when carrying out work!</p>

13.2 EPG-SPRINT X CONTROL UNIT

Pos	K	Stk	Order No.	Designation
		1	2324731	EPG-SPRINT X control unit (for manual and automatic systems)
		2	9951117	Thermal delay fuses 1.0 A (included in EPG-SPRINT X)

14 DECLARATION OF WARRANTY AND CONFORMITY

14.1 IMPORTANT NOTES REGARDING PRODUCT LIABILITY

As a result of an EC regulation effective from January 1, 1990, the manufacturer shall only be liable for his product if all parts originate from him or are approved by him, and if the devices are properly mounted, operated and maintained.

The manufacturer will not be held liable or will only be held partially liable if third-party accessories or spare parts have been used.

With genuine WAGNER accessories and spare parts, you have the guarantee that all safety regulations are complied with.

14.2 WARRANTY CLAIM

Full warranty is provided for this device:

We will at our discretion repair or replace free of charge all parts which within 24 months in single-shift, 12 months in 2-shift or 6 months in 3-shift operation from date of receipt by the purchaser are found to be wholly or substantially unusable due to causes prior to the sale, in particular faulty design, defective materials or poor workmanship.

The type of warranty provided is such that the device or individual components of the device are either replaced or repaired as we see fit. The resulting costs, in particular shipping charges, road tolls, labor and material costs will be borne by us except where these costs are increased due to the subsequent shipment of the device to a location other than the address of the purchaser.

We do not provide warranty for damage that has been caused or contributed to for the following reasons:

Unsuitable or improper use, faulty assembly or commissioning by the purchaser or a third party, normal wear, negligent handling, defective maintenance, unsuitable coating products, substitute products and the influence of chemical, electrochemical or electrical agents, except when the damage is attributable to us.

Components that have not been manufactured by WAGNER are subject to the original warranty of the manufacturer.

Replacement of a component does not extend the period of warranty of the device.

The device should be inspected immediately upon receipt. To avoid losing the warranty, we or the supplier company are to be informed in writing about obvious faults within 14 days upon receipt of the device.

We reserve the right to have the warranty compliance met by a contracting company.

The services provided by this warranty are dependent on evidence being provided in the form of an invoice or delivery note. If the examination discovers that no warranty claim exists, the costs of repairs are charged to the purchaser.

It is clearly stipulated that this warranty claim does not represent any constraint on statutory regulations or regulations agreed to contractually in our general terms and conditions.

J. Wagner AG

14.3 CE DECLARATION OF CONFORMITY

Herewith we declare that the supplied version of

- EPG-SPRINT X, Order No. 2324731

complies with the following provisions applying to it:

- 94/9/EC (ATEX Directive)
- 2004/108/EC (EMC Directive)
- 2002/95/EC (RoHS Directive)
- 2002/96/EC (WEEE Directive)

Applied standards, in particular:

- pr DIN EN 50050-2: 2011
- DIN EN 50050: 2007
- DIN EN 50177: 2010
- DIN EN 1127-1: 2011
- DIN EN 60079-0: 2010
- DIN EN 60079-7: 2007
- DIN EN 60079-31: 2010
- DIN EN 60204-1: 2007
- DIN EN ISO 80079-34: 2012
- DIN EN 62061: 2010
- DIN EN ISO 13849-1: 2008
- DIN EN 60529: 2000
- DIN EN ISO 12100: 2011
- DIN EN 61000-6-2: 2011
- DIN EN 61000-6-4: 2011
- BGI 764

Identification:



CE Certificate of Conformity

The CE certificate of conformity is enclosed with this product. If needed, further copies can be ordered through your WAGNER dealer by specifying the product name and serial number.

Order number:

EPG-SPRINT X 2327595

14.4 EC-TYPE EXAMINATION CERTIFICATE

Physikalisch-Technische Bundesanstalt
Braunschweig und Berlin



(1) **EC-TYPE-EXAMINATION CERTIFICATE**
(Translation)

- (2) Equipment and Protective Systems Intended for Use in Potentially Explosive Atmospheres - **Directive 94/9/EC**
(3) EC-type-examination Certificate Number:

PTB 12 ATEX 5001

- (4) Equipment: EPG-Sprint X control module and EPG S2 dual control module, for controlling electrostatic powder coating devices of the types PEM and PEA of the C2, C3, C4, T3, T4, and X1 generations
(5) Manufacturer: J. Wagner AG
(6) Address: Industriestrasse 22, 9450 Altstätten, Switzerland
(7) This equipment and any acceptable variation thereto are specified in the schedule to this certificate and the documents therein referred to.
(8) The Physikalisch-Technische Bundesanstalt, notified body No. 0102 in accordance with Article 9 of the Council Directive 94/9/EC of 23 March 1994, certifies that this equipment has been found to comply with the Essential Health and Safety Requirements relating to the design and construction of equipment and protective systems intended for use in potentially explosive atmospheres, given in Annex II to the Directive.
The examination and test results are recorded in the confidential test report PTB Ex 12-51176.
(9) Compliance with the Essential Health and Safety Requirements has been assured by compliance with: **DIN EN 50050:2007, prEN 50050-2:2011, DIN EN 50177:2010**
(10) If the sign "X" is placed after the certificate number, it indicates that the equipment is subject to special conditions for safe use specified in the schedule to this certificate.
(11) This EC-type-examination Certificate relates only to the design, examination and tests of the specified equipment in accordance to the Directive 94/9/EC. Further requirements of the Directive apply to the manufacturing process and supply of this equipment. These are not covered by this certificate.
(12) The marking of the equipment shall include the following:



 **II 3(2)D IP64 80 °C**

Zertifizierungssektor Explosionsschutz
On behalf of PTB:

Braunschweig, 6 August 2012

Dr.-Ing. M. Beyer
Direktor und Professor



sheet 1/3

EC-type-examination Certificates without signature and official stamp shall not be valid. The certificates may be circulated only without alteration. Extracts or alterations are subject to approval by the Physikalisch-Technische Bundesanstalt. In case of dispute, the German text shall prevail.

14.5 FM APPROVAL

The EPG-SPRINT X control unit is approved in the USA and Canada using configuration drawing no. 2309729.

**CERTIFICATE OF COMPLIANCE**

HAZARDOUS (CLASSIFIED) LOCATION ELECTRICAL EQUIPMENT

HAZARDOUS LOCATION ELECTRICAL EQUIPMENT
PER CANADIAN REQUIREMENTS

The Sprint AF USA and Sprint 60L USA Manual Powder Spray Systems for use in Electrostatic Powder Finishing Applications using Class II Spray Materials when configured in accordance with drawing 2309729. The Sprint AF USA and Sprint 60L USA Trolleys are rated for use in Class II, Division 2, Groups E, F and G Hazardous (Classified) Locations. The PEM-X1, PEM-X1-CG, PEM-C4-HiCoat FM and PEM-C4-ERGO FM Manual Applicators, and PEA-C4-HiCoat FM and PEA-C4XL-HiCoat FM Automatic Applicators with either EPG-Sprint X, EPG-Sprint FM, EPG-S2 FM, EPG-Prima and EPG-2008 Control Units for use in Electrostatic Powder Finishing Applications using Class II Spray Materials when configured in accordance with drawing 2309729. Control Units are rated for use in Class II, Division 2 Hazardous (Classified) Locations. The EPG-Sprint X, EPG-Sprint FM Control Units have an indoor environmental rating of IP64. The PEM-C4-ERGO FM Manual Applicator, and PEA-C4-HiCoat FM and PEA-C4XL-HiCoat FM Automatic Applicators have an environmental rating of IP54.

Special conditions of use:

The source electrical connection for the Control Units are to be connected in an unclassified (ordinary) location only.

Equipment Ratings:

The applicators are rated for use in Electrostatic Powder Finishing Applications using Class II Spray Materials when configured in accordance with drawing no. 2309729. The associated control units and mobile powder systems are rated for use in Class II, Division 2, Group E, F and G Hazardous Locations. The EPG-Sprint X EPG-Sprint FM Control Units have an environmental rating of IP64. The PEM-C4-ERGO FM Manual Applicator, PEA-C4-HiCoat FM, PEA-C4XL-HiCoat FM Automatic Applicators have an environmental rating of IP54.



FM Approvals
1151 Boston Providence Turnpike
P.O. Box 9102 Norwood, MA 02062 USA
T: 781 762 4300 F: 781-762-9375 www.fmapprovals.com



DEVICE CONFIGURATION APPENDIX

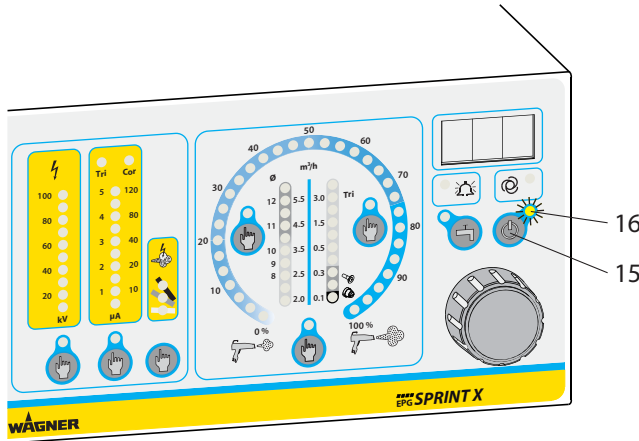

Procedure:

1. To access special device configuration, switch the unit to "Standby" with the "Standby" button 15. The yellow "Standby" LED 16 lights up.

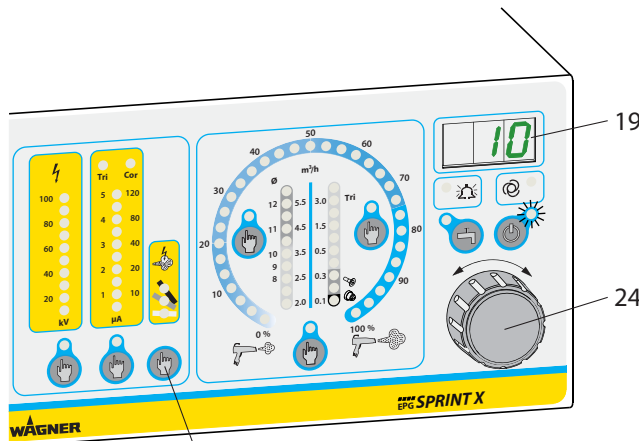

2. Press "Characteristic Slope" button 31 and hold it down.
3. Turn the universal rotary controller 24 with the other hand until the LED display 19 shows the number "10". Then release the "Characteristic Slope" button 31. The unit is now in configuration mode. The scrolling text "Configuration" is displayed.

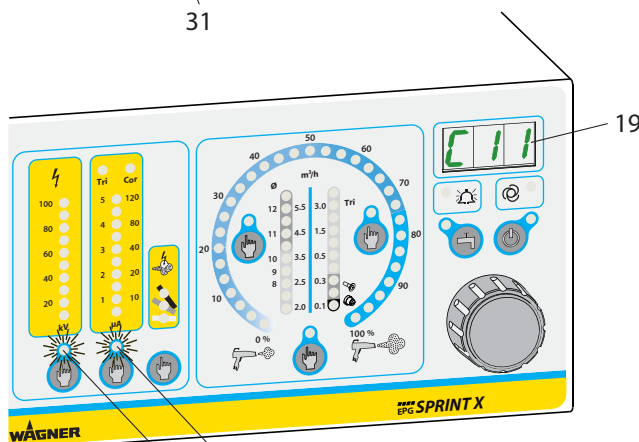

4. The LED display 19 now shows the first configuration setting C11. At the same time, the two yellow LED displays "High-voltage" 28 and "Spray Current" 30 will flash.

P_01747

For ease of operation the configuration settings are divided into 4 groups. The first two groups are for the end user, the third group is for Wagner Service and the fourth group is reserved for Wagner production sites or the Wagner Service Center, which have the necessary infrastructure.

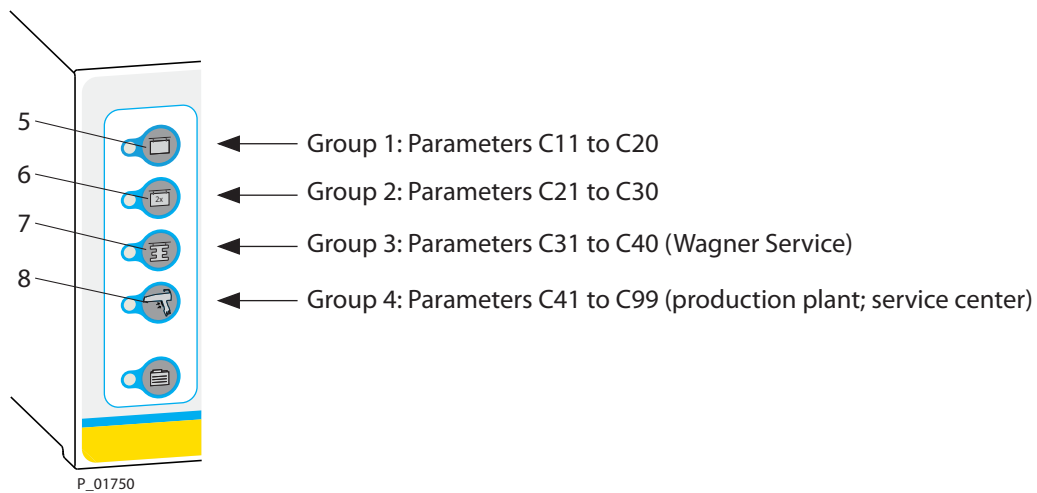

It is possible to switch between the different groups using the "Recipe" buttons 5, 6, 7 and 8.

A1 SETTING EXAMPLE: PARAMETER C11

This parameter is used to set the gun type (Tribo or Corona). The control unit is factory-set to Corona.

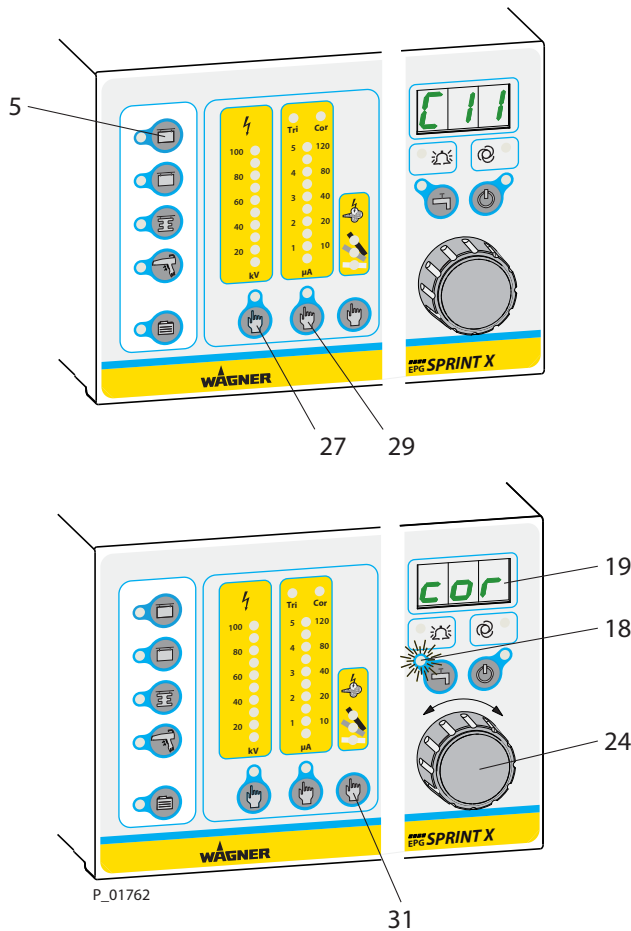

Procedure:

1. If parameter C11 is not set on the control unit, select parameter group 1 by pressing recipe button 5 and use the "High-voltage" button 27 or the "Current Limitation" button 29 to set the parameter to C11.

2. The parameter value is now shown by pressing the "Characteristic Slope" button 31.
3. The LED display 19 shows "cor". At the same time, the blue "Purge" LED 18 will flash.
4. All setting options can then be viewed in turn by turning the universal rotary controller 24.

The display shows:

- "cor" for Corona manual and automatic guns
- "tri" for Tribo manual and automatic guns
- "aut" for automatic switching from Tribo to Corona, if the user frequently switches between Tribo and Corona.

Limitation: A Corona spray gun is always shown when the control unit is switched on. A Tribo gun is only recognized when the high-voltage and powder feed are activated.

This setting is retained until the control unit is switched off.

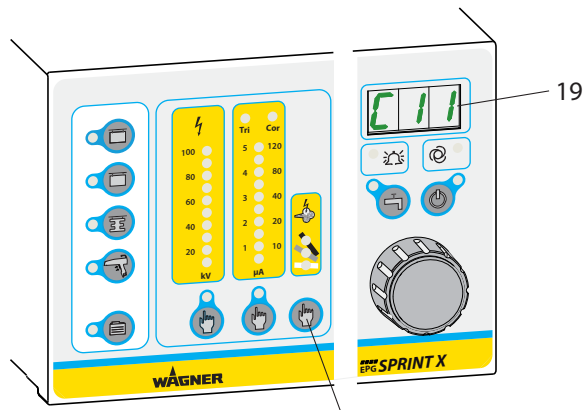

5. There are now two options:
 - a) If you want to keep the old setting, regardless of what is currently displayed, press the "Characteristic Slope" button 31 again. The LED display 19 shows C11 again.

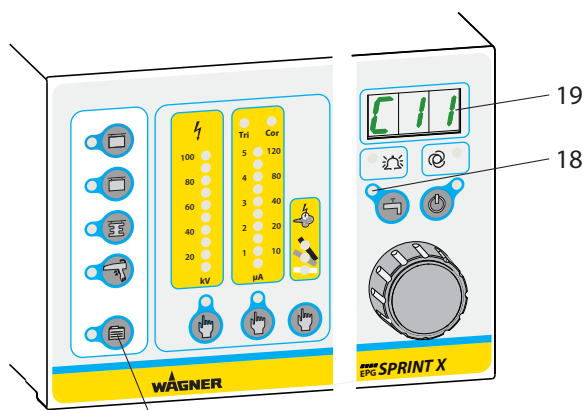

- b) If you want to save the changed setting, press the "Additional Recipes" button 25 to save the setting until the blue "Purge" LED 18 no longer flashes. The LED display 19 then shows the parameter number again (in this example, C11). Proceed in the same way for all other parameters. The list below provides an overview of all the other parameters.

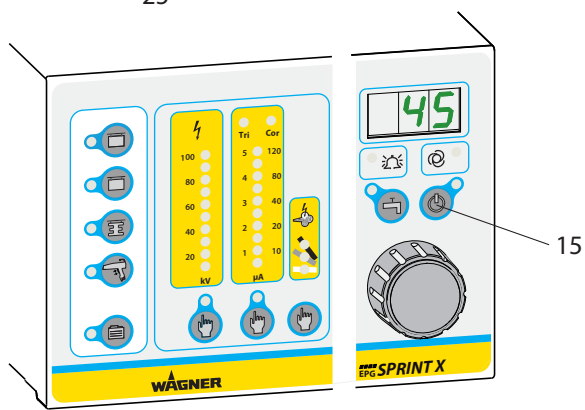

6. To exit the configuration, switch control unit to standby mode by pressing the "Standby" button 15. Pressing this button again returns the control unit to normal operating mode.

P_01763

A2 SETTING EXAMPLE: PARAMETER C13

The lock is activated and deactivated with this parameter. The control unit is factory-set to "OFF" (lock deactivated).

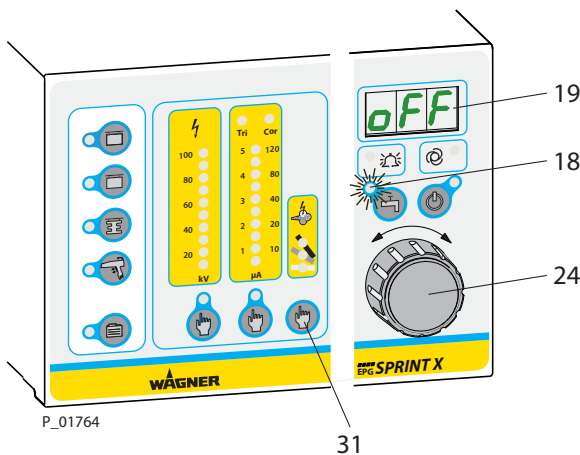
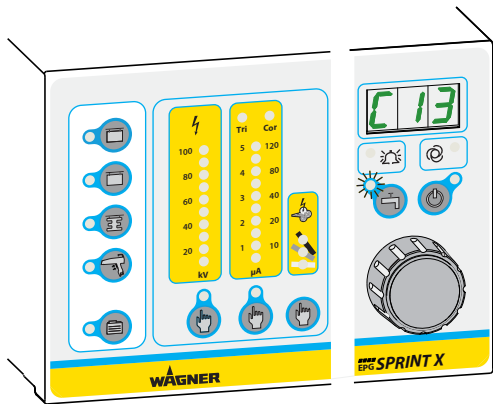
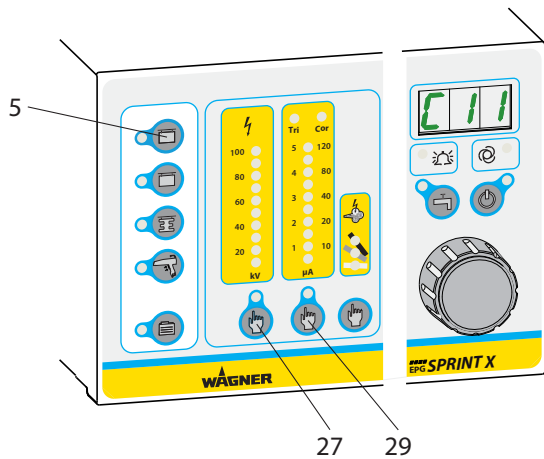

P_01764

Procedure:

1. If parameter C13 is not set on the control unit, select parameter group 1 by pressing recipe button 5 and use the "High-voltage" button 27 or the "Current Limitation" button 29 to set the parameter to C13.

2. The parameter value is now shown by pressing the "Characteristic Slope" button 31.
3. The LED display 19 shows "off". At the same time, the blue "Purge" LED 18 will flash.
4. All setting options can then be viewed in turn by turning the universal rotary controller 24.

The display shows:

- OFF with lock deactivated.
 - ON with lock activated.
- No program values can be adjusted when the lock is activated.

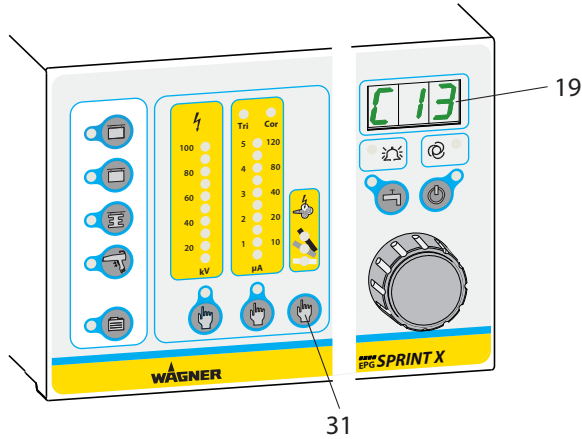

5. There are now two options:
 - a) If you want to keep the old setting, regardless of what is currently displayed, press the "Characteristic Slope" button 31 again. The LED display 19 shows C13 again.

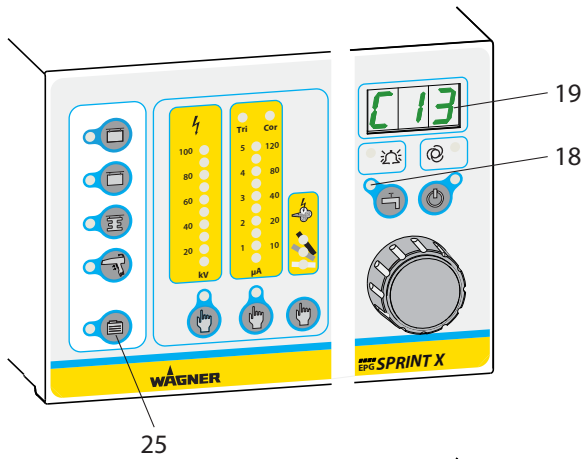

- b) If you want to save the changed setting, press the "Additional Recipes" button 25 to save the setting until the blue "Purge" LED 18 no longer flashes. The LED display 19 then shows the parameter number again (in this example, C13). Proceed in the same way for all other parameters. The list below provides an overview of all the other parameters.

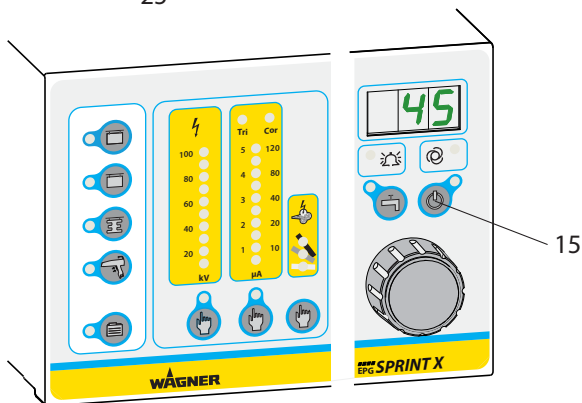

6. To exit the configuration, switch control unit to standby mode by pressing the "Standby" button 15. Pressing this button again returns the control unit to normal operating mode.

P_01765

A3 TABLE OF PARAMETERS

Parameter		Value	Description
C11	Gun charging type	cor (Factory setting)	Wagner Corona spray guns can be connected to the unit; a Tribo gun will trigger a fault.
		tri	Wagner Tribo guns can be connected to the unit; a Corona gun will not trigger a fault.
		aut	Tribo or Corona spray guns can be connected to the unit. The system only changes to the correct type after it is first switched on with the spray gun's trigger or the connected CCM module.
C12	Selection reset function	OFF	The selection function is switched off. A selection is retained until another selection is made.
		ON (Factory setting)	Selection function is switched on: after 5 seconds, the selection automatically returns to the powder quantity setting.
C13	Lock	OFF (Factory setting)	Lock is deactivated.
		ON	Lock is activated, values cannot be changed, user can only select recipes and control functions. Recipe values cannot be changed.
		Pro	Operating inhibit sometimes activated. Recipe storage is blocked, otherwise function as in the "OFF" position. Values can be changed temporarily.
C14	"Double Click" function	OFF	"Double Click" function is deactivated.
		ON (Factory setting)	The "Double Click" function is activated - when the manual gun's trigger is pressed twice to switch on, the program jumps to the "Double Click" recipe; at the next switch-on the previous recipe is selected again.
C15	Operating hours counter	only display	The actual coating hours are counted. The numerical value displayed should be multiplied by 100. Examples: 0.15 → 0.15 * 100 h = 15 operating hours 050 → 50 * 100 h = 5,000 operating hours

	Parameter	Value	Description
C16	External recipe selection (Pulse control using remote control bush)	OFF (Factory setting)	The recipe is selected using 4 different pulse lengths to select recipes 1-4. This setting is compatible with the CCM Prima.
		ON	The recipe is selected by using an extended pulse/pause protocol to select all 50 recipes and call up the purge function. This setting should be used if control by a programmable logic controller (PLC) is the same as with a ProfiTech Sprint system. For protocol, see service manuals for EPG-SPRINT X.
C17	Powder output Increase in powder output by activating the feed and atomizing air in parallel. Both these airs must be combined externally by a Y-piece and supplied to the injector's feed air connection. The additional volume differs depending on injector type. The atomizing and Tribo air is no longer available to the spray gun and must be obtained from a different source.	OFF (Factory setting)	"Standard" setting for separate hosing for feed, dosing and atomizing air.
		ON	The feed air and atomizing air outputs are combined for a larger feed air quantity (higher powder output quantity). Attention: The Tribo and atomizing air is no longer available.
C18	Display luminance The display luminance can be set to one of three levels.	0	Full display luminance (default setting)
		1	Medium luminance (reduced brightness)
		2	Minimum luminance (brightness greatly reduced)
C19	Delete created recipes	NO (Factory setting)	No action.
		res	All recipes are reset to the delivery condition if "res" is saved with button 25.

	Parameter	Value	Description
C20	Reset unit to delivery condition	NO (Factory setting)	No action.
		res	All settings except recipes are reset to the delivery condition if "res" is saved with button 25.
C21	Vibrator motor control after-run	10 s (Factory setting)	Vibrator motor overruns for 10 seconds.
		OFF	Vibrator motor is not controlled; always off.
		ON	Vibrator motor is always switched on.
		1 s - 240 s	Vibrator motor is switched on with the manual gun's trigger lever and overruns for X seconds; can be set from 1 second to 240 seconds.
C22	Hose purging (dosing air without feed air)	OFF (Factory setting)	Hose purging switched off.
		1 s - 10 s	Hose purging time overrun in seconds.
C23	Hose purging intensity of dosing air	100% (Factory setting)	Hose purging intensity 100%.
		1% - 100%	Hose purging intensity from 1% to 100%.
C25	Tribo current minimum monitoring	OFF (Factory setting)	Tribo current is not monitored.
		0.1 μ A - 5 μ A	If the Tribo current does not reach the set values for more than 10 seconds, a warning is issued (see Warnings and Fault Messages).

	Parameter	Value	Description
C26	Manual gun with external control operating mode	OFF (Factory setting)	Standard function. The device automatically recognizes the manual or automatic gun. The properties of the corresponding manual or automatic gun operating mode is described in the chapter on "Commissioning" and in the service manuals.
		1	Operation always with manual gun. The remote interface is not used for controlling the vibrator, instead the remote interface provides the device with a release and the OFF-ON command for cleaning (continuous purging). The remote interface is described in the service manuals.
		2	Same as described for value 1, but the purge button at the operating front is without function (disabled).
C31-C40	Password protection		Password-protected; only for Wagner personnel or appropriately trained persons.
C41-C99	Password protection		Password-protected; only for Wagner production sites or the Wagner Service Center with appropriate test equipment.

From software version 2.10, two additional parameters are available for special operation with field controllers.

Parameter		Value	Description
C27	Open-circuit voltage limited to a maximum of 40 kV	OFF (Default)	Normal operation with gun
		ON	Special application if a field controller is connected to this control unit. The open-circuit voltage cannot exceed a value of 40 kV.
C28	High-voltage module: Automatic spray current reset	OFF	This setting must be selected if a field controller is used in the system as a whole. It makes no difference whether a gun or a field controller is connected to this control unit.
		ON (Default)	This setting must be selected if a field controller is not used in the system as a whole.

A4 SPRAY CURRENT RESET WHEN USING FIELD CONTROLLERS

Problems when combining field controllers and guns:

When the control unit is operated in normal mode, the automatic spray current reset can suffer a functional fault when positive and negative cascades are combined if all of the guns and field controllers are not connected simultaneously.

Switching off the automatic spray current reset:

The automatic spray current reset can be switched off via configuration parameter "C28 High-voltage module: Automatic spray current reset".

The spray current reset must then be performed manually. There are several ways of doing this.

Spray current reset using the control unit:

When the EPG-SPRINT X control unit is powered up, the reset takes place via the control unit itself.

For this reason, never switch a device on using the mains switch if guns or field controllers are already being used for spraying in the same system. The operator must ensure that this cannot happen.

Basic conditions for manually resetting the spray current:

The operator or higher-level controller must ensure that no gun or field controller (any high-voltage module) has been used for spraying 10 seconds before the reset takes place.

Manual spray current reset option 1:

The reset can be performed by the operator. He/she is responsible for complying with the basic conditions. The reset can be performed by holding down the characteristic slope button for more than 2 seconds. If the reset has been successful, the 3 LEDs on the characteristic slope button light up for approx. 2 seconds in quick succession.

Manual spray current reset option 2:

If the purge function is carried out at the control unit, the spray current is reset once following the completion of the purging process. If the EPG-SPRINT X is used as an automatic gun control unit with an extended transfer protocol at the recipe input of the remote control bush (C26 = "ON"), the reset is not performed during purging as a separate command "63" is available.

Manual spray current reset option 3:

If the EPG-SPRINT X is used as an automatic gun control unit with an extended transfer protocol at the recipe input of the remote control bush (C26 = "ON"), the reset can be called up by sending command "63". (Further information can be found in the service manual in the "Documentation for the Extended Transfer Protocol at the Recipe Input" chapter).

Configuration:

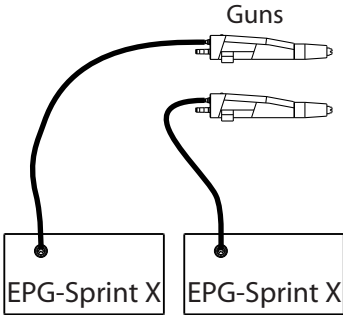
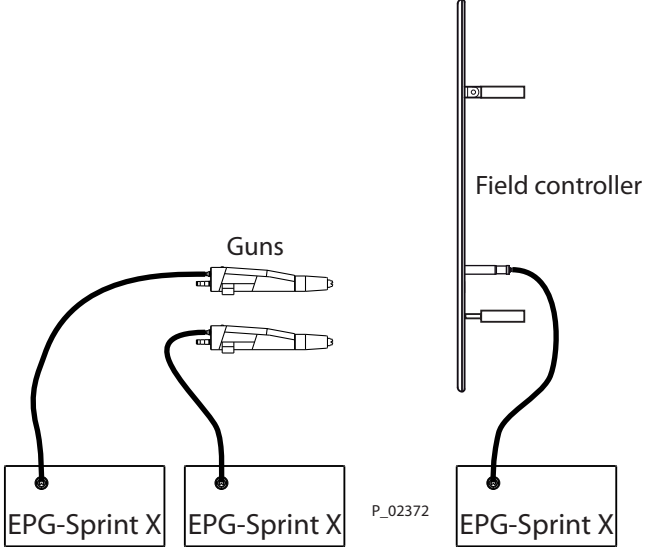
Guns only, no field controller	Combination of guns and field controller	
		
<p>EPG-Sprint X configuration:</p>	<p>EPG-Sprint X configuration (guns):</p>	<p>EPG-Sprint X configuration (field controller):</p>
<ul style="list-style-type: none"> ● C27 = "OFF" 	<ul style="list-style-type: none"> ● C27 = "OFF" 	<ul style="list-style-type: none"> ● C27 = "ON"
<ul style="list-style-type: none"> ● C28 = "ON" 	<ul style="list-style-type: none"> ● C28 = "OFF" 	<ul style="list-style-type: none"> ● C28 = "OFF"

Further information can be found in the field controller operating manual.

BRIEF DESCRIPTION

Operating elements

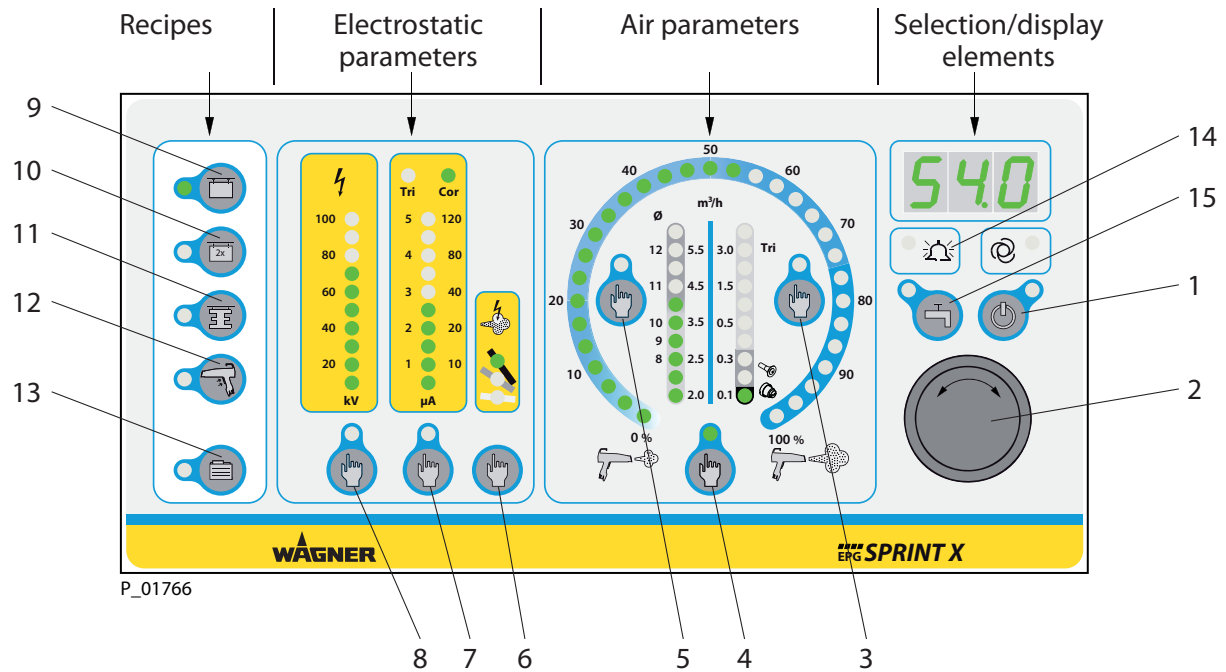

- 1 Button: "Standby" (for switching to standby mode)
- 2 Rotary controller (for selecting recipes and parameters)
- 3 Selection button: "Atomizing/Tribo Air" [m³/h]
- 4 Selection button: "Powder Quantity" [%]
- 5 Selection button: "Total Air Volume" [m³/h]
- 6 Selection button: "Characteristic Slope"
- 7 Selection button: "Current Limitation" [μA]
- 8 Selection button: "High-voltage" [kV]
- 9 Recipe button: "Surface Parts" (coating surface parts)
- 10 Recipe button: "Second Coating"
- 11 Recipe button: "Profile Parts" (coating profile parts)
- 12 Recipe button: "Double Click" (for rapid recipe changes without interrupting the coating process, by simply double-clicking on the gun trigger)
- 13 Recipe button: "Additional Recipes 5-50"
- 14 Display LED: "Fault"
- 15 Button: "Purge" (for quick and easy cleaning of components carrying powder)

Operation of the control unit**1 CHANGING PARAMETERS**

1. Use selection button to select the parameters required.
The yellow LED lights up.

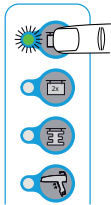

2. Set parameter value with rotary controller.
The value set is shown in LED display.

**2 CALLING / CHANGING / SAVING RECIPES 1-4**

1. Select required recipe by pressing the corresponding recipe button.

2. Set new parameters (electrostatic, air volume) (see 1).

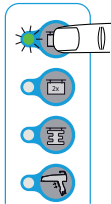

3. Press the recipe button required for around 2 seconds until the LED flashes rapidly.
The recipe is saved with new parameters and can be called up again at any time at the touch of a button.

3 CALLING / CHANGING / SAVING RECIPES 5-50

1. Press Additional Recipes button.



2. Set recipe number with rotary controller.
The recipe number is displayed in the LED display.

3. Set new parameters (see 1).



4. Press Additional Recipes button for around 2 seconds.
The changed parameters are saved.



5. The recipe number is shown flashing in the LED display.



6. Set required recipe number with rotary controller.
(Only necessary if the parameters are to be saved under another recipe number.)

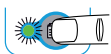

7. Press Additional Recipes button for around 2 seconds.



8. LED display flashes quickly.
Recipe is saved with new parameters.

<p>Germany J. WAGNER GmbH Otto-Lilienthal-Str. 18 Postfach 1120 D- 88677 Markdorf Phone: +49/ 7544/ 505-0 Fax: +49/ 7544/ 505-200 E-mail: service.standard@wagner-group.com</p>	<p>Switzerland J. WAGNER AG Industriestrasse 22 Postfach 663 CH- 9450 Altstätten Phone: +41/ 71/ 757 2211 Fax: +41/ 71/ 757 2222 E-mail: rep-ch@wagner-group.ch</p>
<p>Belgium Estee Industries Leenbeekstraat 9 B- 9770 Kruishoutem Phone: +32/ 9/ 388 5410 Fax: +32/ 9/ 388 5440 E-mail: info@estee-industries.com</p>	<p>Denmark WAGNER Industrial Solution Scandinavia Viborgvej 100, Skægkær DK-8600 SILKEBORG Phone: +45/ 70 200 245 Fax: +45/ 86 856 027 E-mail: info@wagner-industri.com</p>
<p>Great Britain WAGNER Spraytech (UK) Ltd. The Couch House 2, Main Road GB- Middleton Cheney OX17 2ND Phone: +44/ 1295/ 714200 Fax: +44/ 1295/ 710100 E-mail: enquiry@wagnerspraytech.co.uk</p>	<p>France Wagner - Division Solutions Industrielles Parc Gutenberg - Bâtiment F 8 voie la Cardon F- 91127 PALAISEAU Cedex Phone: +33/ 1/ 825/ 011111 Fax: +33/ 1/ 69 19 46 55 E-mail: division.solutionsindustrielles@wagner-france.fr</p>
<p>Netherlands WAGNER Systemen Nederland Proostwetering 105 C NL- 3543 AC Utrecht Phone: +31/ 30/ 2410 688 Fax: +31/ 30/ 2410 765 E-mail: info@wagnersystemen.nl</p>	<p>Italy WAGNER Itep S.p.A Via Santa Veccia, 109 I- 22049 Valmadrera - LC Phone: +39/ 0341/ 212211 Fax: +39/ 0341/ 210200 E-mail: wagnerit@tin.it</p>
<p>Japan WAGNER HOSOKAWA Micron Ltd. No. 9, 1-Chome Shodai Tajka, Hirakata-Shi Osaka 673-1132 Phone: +81/ 728/ 566 751 Fax: +81/ 728/ 573 722 E-mail: sempara@kornet.net</p>	<p>Austria J. WAGNER GmbH Otto-Lilienthal-Str. 18 Postfach 1120 D- 88677 Markdorf Phone: +49/ 7544/ 505-0 Fax: +49/ 7544/ 505-200 E-mail: service.standard@wagner-group.com</p>
<p>Sweden WAGNER Industrial Solutions Scandinavia Skolgatan 61 SE - 568 31 SKILLINGARYD Phone: +46/ 370/ 798 30 Fax: +46/ 370/ 798 48 E-mail: info@wagner-industri.com</p>	<p>Spain WAGNER Spraytech Iberica S.A. P.O. Boc., 132, Ctra. N- 340, KM 1245,4 E- 08750 Molins de Rei (Barcelona) Phone: +34/ 93/ 680 0028 Fax: +34/ 93/ 680 0555 E-mail: info@wagnerspain.com</p>
<p>China WAGNER Spraytech Shanghai Co Ltd. 4 th Flr. No. 395 Jiangchanxi Road Shibei Industrial Zone Shanghai 200436 Phone: +86/ 2166 5221 858 Fax: +86/ 2166 5298 19 E-mail: wagnersh@public8.sta.net.cn</p>	<p>USA WAGNER Systems Inc. 300 Airport Road, Unit 1 Elgin, IL 60123 Phone: +1/ 630/ 503-2400 Fax: +1/ 630/ 503-2377 E-mail: info@wagnersystemsinc.com</p>

WAGNER



Order No. 2329371

Germany

J. WAGNER GmbH
Otto-Lilienthal-Str. 18
Postfach 1120
D- 88677 **Markdorf**
Phone +49/ (0)7544 / 5050
Fax: +49/ (0)7544 / 505200
E-mail: service.standard@wagner-group.com

Switzerland

J. WAGNER AG
Industriestrasse 22
Postfach 663
CH- 9450 **Altstätten**
Phone +41/ (0)71 / 757 2211
Fax: +41/ (0)71 / 757 2222
E-mail: rep-ch@wagner-group.ch

www.wagner-group.com