

C4 HiCoat – the new generation of guns

More efficiency with many new highlights



EFFICIENT

FLEXIBLE

SAFE

WAGNER

www.wagner-systems.com

The new C4 generation of guns – the most important new items at a glance

Reliable application of metallic and UDS powder paints

The new generation of guns from Wagner for even more efficiency and perfection. The integral high voltage cascade with a power rating of up to 100 kV works perfectly and safely. All electronic components are integrated in the robust plastic body of the gun. This means low servicing costs and a much longer service life.



Perfection with metallic coatings

- homogeneous powder cloud
- optimised electrostatics
- uniform distribution with a thin film

High transfer rate

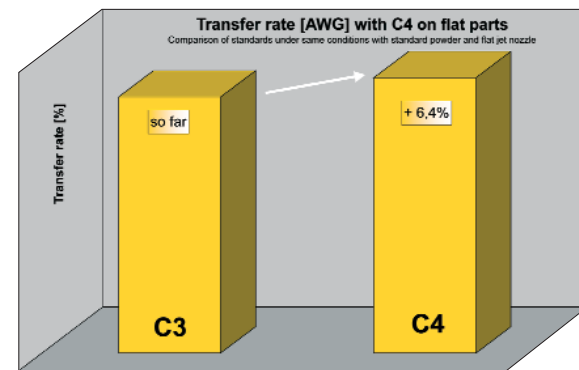

Distinct increase in the transfer rate!

- better charging of the powder
- soft powder cloud
- atomisation selected to suit the work piece

Flex-Nozzle – the variable flat jet nozzle system



Nozzle F1

- soft cloud with wide flat jet for flat parts



Nozzle F2

- dense cloud with narrow flat jet for partial or fast coating



Nozzle F3

- fast cloud with targeted flat jet for reduced edge buildup

The Powerlock system, fast and effective!

Save time when changing powders. The new system for fast effective cleaning.

- sure, automatic cleaning of the powder duct in the gun
- stable positioning of the nozzle components
- easy accessibility to wear parts

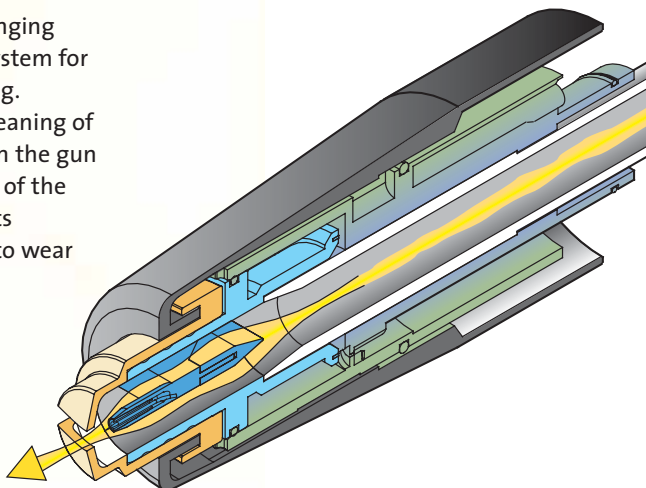

Uniform surface

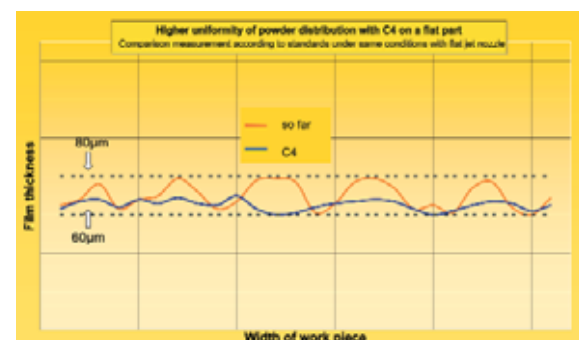

- homogeneous powder cloud
- efficient application of powder

Best equipped for all coating tasks

Safety power

The new safety technology from Wagner for the avoidance of high voltage breakthroughs and blow backs into the powder duct.

- increased electrical safety
- PTB certificate
- certified for Zone 21 internal coating

Physikalisch-Technische Bundesanstalt
Zertifizierungsstelle für Explosionenschutz



Certification Body for Explosion Protection

The highest quality with metallic, special effects and UDS powder!

Distinct optimisation of powder charging and powder flow

Increased application efficiency

New high voltage generation for optimal charging

Uniform film thickness distribution

Optimised surface application due to homogeneous, soft powder cloud

The new C4 HiCoat manual guns



PEM-C4

Super-light and handy – the electrostatic manual gun



PEM-C4 R

Electrostatic manual gun with remote control



PEM-CG4

Powder cup gun for very small quantities

The new C4 HiCoat automatic guns



PEA-C4

Automatic gun for universal use



PEA-C4 XL

Automatic gun – particularly suitable for plastic booths and fast colour changes



PEA-C4 Twin

Twin automatic gun. High efficiency with high throughput. Especially suitable for robot applications



PEA-C4 A

Electronic angle gun for special coating tasks

Corona powder coating

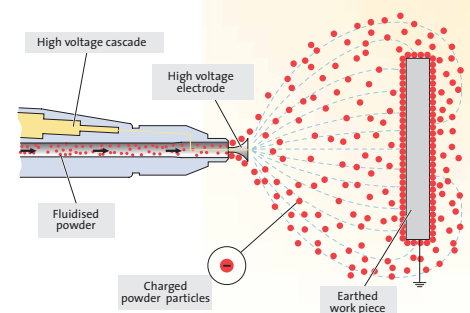

The integral high voltage cascade, with a power rating of up to 100 kV, achieves an extremely high application efficiency and excellent charging of the powder. All electronic components are integrated in the robust plastic body of the gun. This means low servicing costs and a long life.

Corona gun accessories



Round jet nozzles R20, R28, R38
for large areas and uniform film thickness distribution



Nozzle extension 300/150 mm
best suited for coating deep work pieces



Flat jet nozzles F1, F2, F3
for various areas of application

Corona-Star to combat the "orange peel effect"
The orange peel effect can occur if awkward shapes are coated with high

film thickness or if the coating powder used has a tendency to form orange peel easily.

Conversion made easy
Our new accessories fit on all earlier models C2 and C3 – conversion is no problem with the retrofit kits!



Technical application benefits of the Corona-Star:

- considerable reduction in the "picture frame effect"
- better operation with high film thickness
- better penetration power on objects with Faraday cages



Wedge tool
For mounting and demounting the protective wedge in the electrode holder. The main benefit: only the wear part is changed.

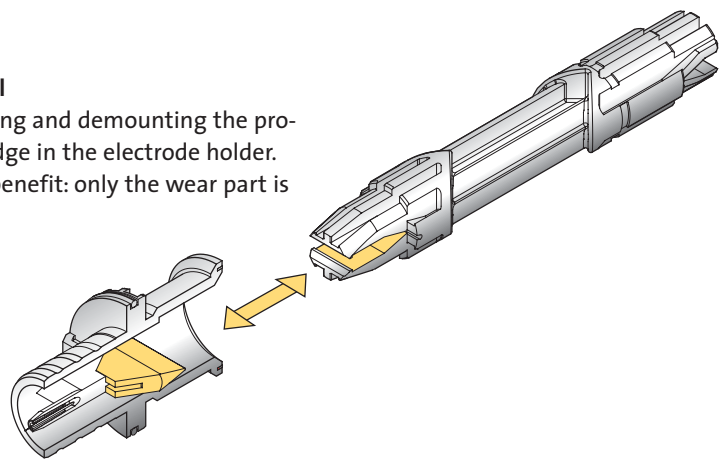

No compromises. Using original spare parts will guarantee your quality standards. All spare parts are labelled with the Wagner logo.



J. Wagner GmbH
Otto-Lilienthal-Str. 18
D-88677 Markdorf
Tel. +49 (0) 7544 505-0
Fax +49 (0) 7544 505-200

J. Wagner AG
Industriestraße 22
CH-9450 Altstätten/SG
Tel. +41 (0) 71 7572211
Fax +41 (0) 71 7572222

www.wagner-systems.com

Tribo – proven technology for outstanding results

Super light and handy – Tribo manual guns



PEM-T3

Manual gun for difficult parts geometries



PEM-T3 R

Tribo manual gun with integral remote control



PEM-TG3

Powder cup gun for very small quantities and also for tribo coating

Effective and economical – Tribo automatic guns



PEA-T3 XL

XL powder gun, particularly suitable for plastic booths, available in Tribo and electrostatics



PEA-T3

Tribo automatic gun – particularly suitable for plastic booths

Tribo spray guns

The new guns are available in the lengths 850 mm, 1,100 mm, and 1,400 mm. Colour changes can be carried out more quickly.

- quick release couplings for fast colour change / gun replacement
- 3 different lengths
- also suitable for metallic powder

Tribo gun accessories



PEA-T3 finger nozzle

In combination with special finger nozzle mouths there is even more effective frictional charging with superb film thickness distribution. A vertical gun arrangement – either rigid or on a short stroke reciprocator – achieves a particularly finely diversified powder cloud.



Nozzles

- round jet nozzle
- gap flat jet nozzle
- wide flat jet nozzle



Nozzle extension

Best suitable for particularly deep work pieces such as e.g. lockers, radiators, drawers

Tribo powder coating

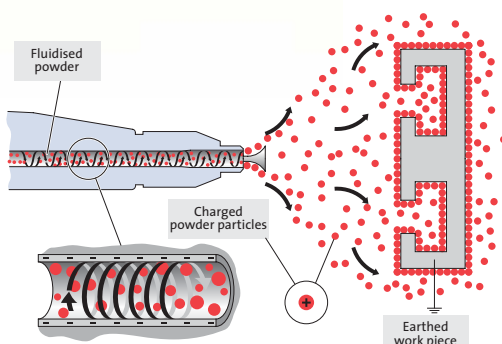

Technical data: Tribo manual guns

	PEM-T3	PEA-T3 R	PEM-TG3
Overall length	500 mm	500 mm	500 mm
Weight	590 g	590 g	890 g
Build	In accordance with ATEX Guideline 94/9/EG, EN 50050		
Enclosure Class	IP 54	IP 54	IP 54
Polarity	Positive	Positive	Positive

Technical data: Tribo automatic guns

	PEA-T3	PEA-T3 XLo.85	PEA-T3 XL1.1	PEA-T3 XL1.4
Overall length	480 mm	1.048 mm	1.299 mm	1.599 mm
Weight	900 g	1.620 g	1.840 g	2.100 g
Build	In accordance with ATEX Guideline 94/9/EG			
Enclosure Class	IP 54	IP 54	IP 54	IP 54
Polarity	Positive	Positive	Positive	Positive

Article list and ordering summary

The way to work more effectively is simple. Do you have questions about individual products or want to order directly by telephone? Use our ordering summary – we will be glad to provide information and advise you.

Customer Service Hotline
Tel. +49 7544 505-800

Article No.	GUNS
0390001	Manual gun PEM-C4
0390002	Manual gun PEM-C4 R
0390003	Airmatic cup gun PEM-CG4
0390004	Airmatic spray gun PEA-C4
0390005	Airmatic spray gun PEA-C4 XL 0.85
0390006	Airmatic spray gun PEA-C4 XL 1.1
0390007	Airmatic spray gun PEA-C4 XL 1.4
0390008	Airmatic spray gun PEA-C4 XL 1.8
0390009	Angle gun PEA-C4 A
0390010	Airmatic spray gun PEA-C4 Twin

Article No.	RETROFIT KITS
0390903	Retrofit kit for PEM-C3/C3 R on C4/C4 R F
0390904	Retrofit kit for PEM-CG2/CG3 on CG4 F
0390905	Retrofit kit for PEA-C2/C3 on C4 F
0390906	Retrofit kit for PEA-C2/C3 XL on C4 XL F
0390907	Retrofit kit for PEA-C2A/C3 A on C4 A F
0390908	Retrofit kit for PEA-C2 Twin on C4 Twin
0390920	Retrofit kit for PEM-C3/C3 R on C4/C4 R
0390921	Retrofit kit for PEM-CG2/CG3 on CG4 R
0390922	Retrofit kit for PEA-C2/C3 on C4 R
0390923	Retrofit kit for PEA-C2/C3 XL on C4 XL R
0390924	Retrofit kit for PEA-C2 A/C3 A on C4 A R
0390925	Retrofit kit for PEA-C2 Twin on C4 Twin R

Article No.	SPARE PARTS
0390909	Powder tube PEM-C4 ET
0390910	Powder tube C4 XL ET
0390911	Powder tube PEA-C4 ET
0390912	Powder tube short PEA-C4 A ET
0390913	Powder tube PEM-CG4 ET
0390914	Powder tube PEA-C4 Twin ET
0390915	Electrode holder C4 F ET
0390310	Wedge C4
0390324	Flat jet nozzle F1
0390325	Flat jet nozzle F2
0390326	Flat jet nozzle F3
0390916	Electrode holder C4 R ET
0390917	Electrode holder C4 R with nozzles
0390207	Round jet nozzle complete R20
0390208	Round jet nozzle complete R28
0390209	Round jet nozzle complete R38
0390900	Wedge tool C4 plus 20 wedges
0390901	Extension, 150 mm, C4
0390902	Extension, 300 mm, C4
0390342	Flat jet nozzle adjustment aid
0390918	Corona-Star Set PEM/PEA/PEA XL/PEM CG
0390919	Corona-Star PEA-C4 Twin

Technical data

C4 automatic guns

	PEA-C4	PEA-C4 XLo.85	PEA-C4 XL1.1	PEA-C4 XL1.4	PEA-C4 XL1.8	PEA-C4 A	PEA-C4 Twin
Overall length	395 mm	974 mm	1.224 mm	1.524 mm	1.524 mm	395 mm	500 mm
Weight	555 g	1.230 g	1.450 g	1.720 g	2.000 g	900 g	1.400 g
Build	To EN 50177						
Enclosure Class	IP 54						
Polarity	Negative	Negative	Negative	Negative	Negative	Negative	Negative

C4 manual guns

	PEM-C4	PEM-C4 R	PEM-CG4
Overall length	395 mm	395 mm	395 mm
Weight	504 g	504 g	890 g
Build	EN 50050	EN 50050	EN 50050
Enclosure Class	IP 54	IP 54	IP 54
Polarity	Negative	Negative	Negative



J. Wagner GmbH
Otto-Lilienthal-Str. 18
D-88677 Markdorf
Tel. +49 (0) 7544 505-0
Fax +49 (0) 7544 505-200

J. Wagner AG
Industriestraße 22
CH-9450 Altstätten/SG
Tel. +41 (0) 71 7572211
Fax +41 (0) 71 7572222